

COMMUNICATION

issued by: **Road traffic safety directorate**

concerning¹: **APPROVAL GRANTED**
~~APPROVAL EXTENDED~~
~~APPROVAL REFUSED~~
~~APPROVAL WITHDRAWN~~
~~PRODUCTION DEFINITELY DISCONTINUED~~

of a component type pursuant to Regulation No. 118

Approval No. **E32*118RII03/01*0028*00** Extension No. **00**Reason for extension: **Not applicable**

Section I

General

- 1.1. Make (trade name of manufacturer): **HIKVISION**
- 1.2. Type: **DS-MP2110**
- 1.3. Means of identification of type, if marked on the device^b: **Not applicable**
- 1.3.1. Location of that marking: **Not applicable**
- 1.4. Name and address of manufacturer: **Hangzhou Hikvision Digital Technology Co., Ltd.
No.555 Qianmo Road, Binjiang District,
Hangzhou City, Zhejiang Province,
P.R. China**
- 1.5. Location of the approval mark: **On self-adhesive label on the package**
- 1.6. Address(es) of assembly plant(s): **Hangzhou Hikvision Digital Technology Co., Ltd.
No.700, Dongliu Road, Binjiang District,
Hangzhou City, Zhejiang, P.R. China
No.299, Qiushi Road, Tonglu Economic
Development Zone, Tonglu Country, Hangzhou,
Zhejiang, P.R. China**

¹ Strike out what does not apply (there are cases where nothing needs to be deleted, when more than one entry is applicable)

^b If the means of identification of type contains characters not relevant to describe the vehicle, component or separate technical unit types covered in this information document, such characters shall be represented in the documentation by the symbol “?” (e.g. ABC??123??).

Section II

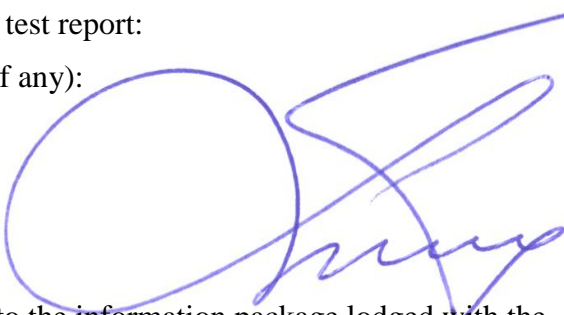
1. Additional information (where applicable): **See Appendix 1**
2. Technical Service responsible for carrying out the tests: **TŪV Rheinland-KTI Ltd.**
3. Date of test report: **20.02.2019**
4. Number of test report: **87-R118-0137/19-00**
5. Remarks (if any): **Not applicable**
6. Place: **6, S.Eizensteina St., Riga
LV-1079, Latvia**
7. Date: **28.02.2019**
8. Signature:  **Jānis Liepiņš**
9. The index to the information package lodged with the Type Approval Authority, which may be obtained on request, is attached.

Attachments: Information package. **DS-MP2110-R118-00**
Test report. **87-R118-0137/19-00, 20.02.2019**



Appendix 1

**Appendix to type approval communication form No. E32*118R1103/01*0028*00
concerning the type approval of a component type pursuant to Regulation No. 118**

- | | | |
|--------|---|-----------------------|
| 1. | Additional information. | |
| 1.1. | Interior materials | |
| 1.1.1. | The direction which the component may be installed: | Not applicable |
| 1.1.2. | Fulfils the requirements in paragraph 6.2.2.: yes / not applicable ¹ | |
| 1.1.3. | Compliance has been checked for components approved as completed devices: yes / no ¹ | |
| 1.1.4. | Any restrictions of use and installation requirements: | Not applicable |
| 1.2. | Insulation materials | |
| 1.2.1. | The direction which the component may be installed: | Not applicable |
| 1.2.2. | Compliance has been checked for components approved as complete devices: yes / no ¹ | |
| 1.2.3. | Any restrictions of use and installation requirements: | Not applicable |
| 1.3. | Electric cables | |
| 1.3.1. | Any restrictions of use and installation requirements: | No |
| 2. | Remarks: | Not applicable |



¹ Strike out what does not apply.

INFORMATION DOCUMENT

Document No.: DS-MP2110-R118-00
Issue Date: 2019.1.29

**uniform provisions concerning the
burning behaviour and/or the capability to repel fuel or lubricant of materials used in the con-
struction of certain categories of motor vehicles**

**Part II – Approval of a component with regard to its burning behaviour and/or its capability to
repel fuel or lubricant installed in the interior compartment, the engine compartment or any
separate heating compartment**

**UN-Regulation No. 118
Amend. 03, Suppl. 1**



HIKVISION

Manufacturer : Hangzhou Hikvision Digital Technology Co., Ltd.

Type : DS-MP2110

AMENDMENT

Version	Approval No.	Modification / Correction	Date
00	---	First application	Jan 29, 2019

CONTENT

1 General.....3

2 Interior materials.....3

3 Insulation materials.....3

4 Electric Cables.....3

Annex 1 Photo of product.....4-5

Annex 2 Specification of cable.....6



HIKVISION

Manufacturer : Hangzhou Hikvision Digital Technology Co., Ltd.

Type : DS-MP2110

- 1 General
- 1.1 Make (trade name of manufacturer) : HIKVISION
- 1.2 Type and general commercial descriptions : Type: DS-MP2110
Commercial descriptions:
DS-MP2110-10,
DS-MP2110-XX,
DS-MP2100-XX
- 1.3 Name and address of manufacturer : Hangzhou Hikvision Digital Technology Co., Ltd.
No.555 Qianmo Road, Binjiang District, Hangzhou City, Zhejiang Province, China
- 1.4 In the case of components and separate technical units, location and method of affixing of the ECE approval mark: : On self-adhesive label on the package
- 1.5 Name(s) and address(es) of assembly plant(s) : Hangzhou Hikvision Digital Technology Co., Ltd.
No.700, Dongliu Road, Binjiang District, Hangzhou City, Zhejiang, China;
No.299, Qiushi Road, Tonglu Economic Development Zone, Tonglu Country, Hangzhou, Zhejiang Province, China
- 2. Interior materials : Not applicable
- 3. Insulation Materials : Not applicable
- 4. Electric Cables
- 4.1. Material(s) used for : Connecting MNVR & Camera
- 4.2. Base material(s)/designation : See Annex 2
- 4.3. Composite/single material, number of layers : See Annex 1
- 4.4. Type of coating : Not applicable
- 4.5. Maximum/minimum thickness : See Annex 2
- 4.6. Type approval number, if available : Not applicable



HIKVISION

Manufacturer : Hangzhou Hikvision Digital Technology Co., Ltd.

Type : DS-MP2110

Annex 1 Photo of product

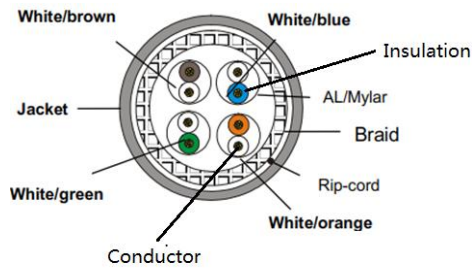
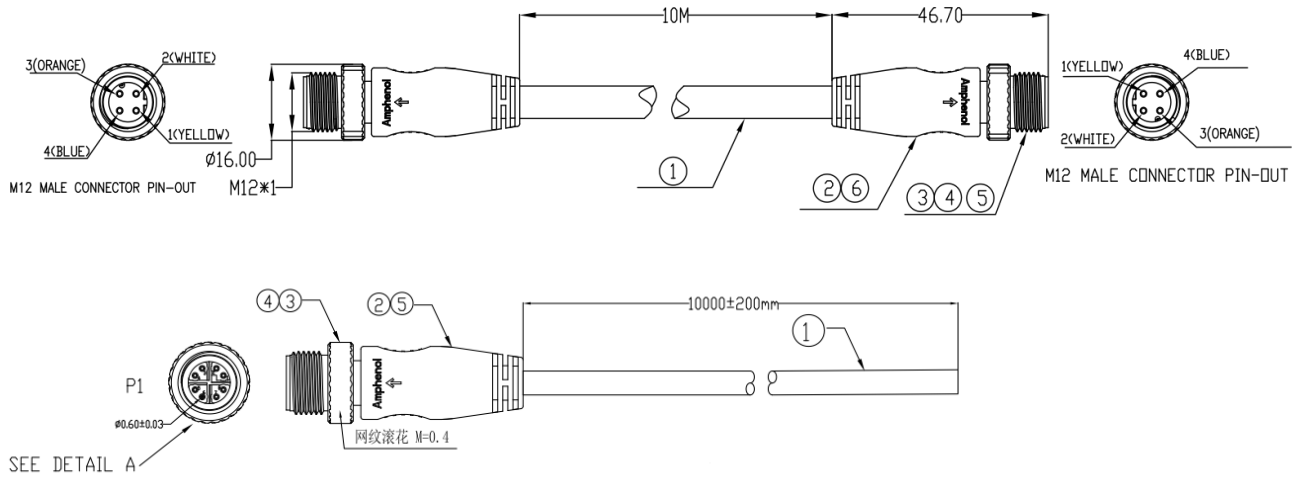

HIKVISION

Manufacturer : Hangzhou Hikvision Digital Technology Co., Ltd.

Type : DS-MP2110

Approval mark:

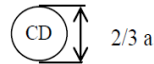

a ≥ 8 mm

HIKVISION

Cable Assembly

Model: DS-MP2110

Approval number

SN: 400345678



Made in China

Manufacturer: Hangzhou Hikvision Digital Technology Co.,Ltd

Address: No.555 Qianmo Road, Binjiang District, Hangzhou 310052, China

Location of approval mark: On self-adhesive label on the package



HIKVISION

Manufacturer : Hangzhou Hikvision Digital Technology Co., Ltd.

Type : DS-MP2110

Annex 2 Specification of cable

Sheath Printing	Sheath Printing ZHAOLONG CABLE PATCH S/FTP CAT6A 4/26AWG PVC ****m dd/mm/yyyy		
Conductor	Material	stranded-Bare Copper	
	dimension.(mm)	26AWG(7/0.16)	
Insulation	Material	Skin-foam-skin PE	
	Diameter	1.00±0.05 mm	
Inner Screening Material	AL/Mylar	Drain wire	No
Outer Screening Material	Tinned copper 16/7/0.10mm	Coverage	60%
Sheath	Thickness	0.55±0.05 mm	
	External O.D. (Avg.)	6.3±0.3mm	
	Surface	Clean	
	Material	PVC, RoHS	
	Color	Black	
Core Color	1. White/Blue	2. White/Orange	
	3. White/Green	4. White/Brown	
Rip-cord	Yes		



Type : DS-MP2110
Manufacturer : Hangzhou Hikvision Digital Technology Co., Ltd.

Precisely Right.

TEST REPORT

according to UN-Regulation

Uniform provisions concerning the Burning Behaviour and/ or the capability to repel fuel or lubricant of materials used in the construction of certain categories of motor vehicles

Part II — Approval of a component with regard to its burning behaviour and/or its capability to repel fuel or lubricant installed in the interior compartment, the engine compartment or any separate heating compartment

UN-Regulation No. 118

as last amended by

Amend. 03, Suppl. 1

Previously granted

UNECE approval : --

Structure of the Test Report

Item No.

0. General information
1. Tested vehicle(s) / object(s)
2. Test record
3. List of appendices
4. Statement of conformity

The Test Report shall be reproduced and published in full by the client only. It shall however be reproduced partially with the written permission of the Technical Service only.

Type : DS-MP2110
 Manufacturer : Hangzhou Hikvision Digital Technology Co., Ltd.

0. General information

- 0.1. Make (trade name of the manufacturer) : HIKVISION
- 0.2. Type : DS-MP2110
- 0.3. Category of vehicle : n.a.
- 0.4. Name and address of the manufacturer : Hangzhou Hikvision Digital Technology Co., Ltd.
 No.555 Qianmo Road, Binjiang District, Hangzhou City, Zhejiang Province, China
- 0.5. No. of the information folder : DS-MP2110-R118-00
 - Date of issue : January 29, 2019
 - Date of last change : --

1. Tested ~~vehicle(s)~~/ object(s)

- 1.1. Description
- 1.1.1. ~~Vehicle~~/ object : [~~Vehicle~~] [Object]
 Commercial description : DS-MP2110-10
 Type(s) ~~variant(s)~~/version(s) : DS-MP2110
 Identification number : n.a.
- 1.1.2. Condition of ~~vehicle(s)~~/Object(s) : New/~~used~~/~~pretested~~
- 1.2. Worst case selection : The determination of worst case was done according to internal procedure of the Technical Service (QMA 1.301.005, section 6.2.2.2)
- 1.3. Remarks : All versions of the ~~vehicle~~ / object type as stated in the information folder are covered by the ~~tested vehicle version(s)~~ and tested object(s) respectively.

Type : **DS-MP2110**
 Manufacturer : **Hangzhou Hikvision Digital Technology Co., Ltd.**

2. Test record

- 2.1. Equipment for measuring and testing : The test facilities / measurement equipment used were in compliance with the test requirements.
- 2.1.1. Specifications for the test site : n.a.
- 2.1.2. Subcontracting : n.a.
- 2.2. Test results : Passed /~~failed~~
- 2.2.1. Horizontal burning behaviour : n.a.
- 2.2.2. Melting behaviour : n.a.
- 2.2.3. Vertical burning behavior : n.a.
- 2.2.4. Complete device : n.a.
- 2.2.5. Repel fuel or lubricant : n.a.
- 2.2.6. Flame propagation test for electric cable : Flame is extinguish within 70s and not less than 50mm insulation at the top of the test sample is remain unburned.
- 2.2.7. Mark with trade name and type : The samples are clearly and indelibly marked with the applicant's trade name and the type designation.
- 2.2.8. Alternative test provisions : n.a.
- 2.2.9. Attributive tests : n.a.
- Remark concerning extension : ~~The type has been tested according to the modification(s) mentioned in appendix O.~~
~~The new parts meet the requirements of the regulation / directive.~~
~~An actual practical test of the type was not necessary.~~
~~The results of the previous test(s) are still valid.~~
- 2.3. Additional information : The results of the test refer exclusively to the object(s) mentioned under point 1.1. of this report.
- Test site : Changzhou Jinbiao Railway Transportation Technical Service Co., Ltd.
 No. 164, Wuyi Road, Qishuyuan Economic Development Zone, Changzhou, Jiangsu, China
- Test date : February 19, 2019
- 2.4. Remarks : --

Type : DS-MP2110
Manufacturer : Hangzhou Hikvision Digital Technology Co., Ltd.

3. List of Appendices

Appendix 0 : List of modifications
Appendix 1 : Test result

4. Statement of conformity

The in point 0.5. mentioned information folder and the type described in that comply with the requirements mentioned on page 1.

With regard to the required level of performance to be achieved, the tested items were representative for the type to be approved (see point 1.2).

The mentioned test results refer to the ~~vehicle(s)~~ object(s) described under point 1.1 of this report.

Engineering centre Shanghai / February 20, 2019



Jerry Li
Expert Technical Service

Type : DS-MP2110
Manufacturer : Hangzhou Hikvision Digital Technology Co., Ltd.

Precisely Right.

Appendix 0

List of modifications

Correction of : ---
Modification of : ---
Addition of : ---
Deletion of : ---



Type : DS-MP2110
 Manufacturer : Hangzhou Hikvision Digital Technology Co., Ltd.

Precisely Right.

Test result

Appendix 1

Flame propagation test for electric cable

Color: Black

Specimen	Dimension (mm)	Burning duration (s)	Unburnt length at the top (mm)	Remark
1	> 600	< 1	> 50	--
2	> 600	< 1	> 50	--
3	> 600	< 1	> 50	--
4	> 600	< 1	> 50	--
5	> 600	< 1	> 50	--

