



# Vehicle-mounted Turret Camera User Manual

UD.6L0201D1995A02

Thank you for purchasing our product. If there are any questions, or requests, please do not hesitate to contact the dealer.

This manual may contain several technical incorrect places or printing errors, and the content is subject to change without notice. The updates will be added to the new version of this manual. We will readily improve or update the products or procedures described in the manual.

### Privacy Notice

Surveillance laws vary by jurisdiction. Check all relevant laws in your jurisdiction before using this product for surveillance purposes to ensure that your use of this product conforms.

Please refer to the product specification for camera parameters and functions.

### Regulatory Information

#### FCC Information

**FCC compliance:** This equipment has been tested and found to comply with the limits for a digital device, pursuant to part 15 of the FCC Rules. These limits are designed to provide reasonable protection against harmful interference when the equipment is operated in a commercial environment. This equipment generates, uses, and can radiate radio frequency energy and, if not installed and used in accordance with the instruction manual, may cause harmful interference to radio communications. Operation of this equipment in a residential area is likely to cause harmful interference in which case the user will be required to correct the interference at his own expense.

#### FCC Conditions

This device complies with part 15 of the FCC Rules. Operation is subject to the following two conditions:

1. This device may not cause harmful interference.
2. This device must accept any interference received, including interference that may cause undesired operation.

### EU Conformity Statement



This product and - if applicable - the supplied accessories too are marked with "CE" and comply therefore with the applicable harmonized European

standards listed under the Low Voltage Directive 2006/95/EC, the EMC Directive 2004/108/EC, the RoHS Directive 2011/65/EU.



2012/19/EU (WEEE directive):

Products marked with this symbol cannot be disposed of as unsorted municipal waste in the European Union. For proper recycling, return this product to your local supplier upon the purchase of equivalent new equipment, or dispose of it at designated collection points. For more information see: [www.recyclethis.info](http://www.recyclethis.info).



2006/66/EC (battery directive): This product contains a battery that cannot be disposed of as unsorted municipal waste in the European Union.

See the product documentation for specific battery information. The battery is marked with this symbol, which may include lettering to indicate cadmium (Cd), lead (Pb), or mercury (Hg). For proper recycling, return the battery to your supplier or to a designated collection point. For more information see: [www.recyclethis.info](http://www.recyclethis.info).

### Industry Canada ICES-003 Compliance

This device meets the CAN ICES-3 (A)/NMB-3(A) standards requirements.

# 1 Introduction

## 1.1 Product Features

This series of camera adopts new generation sensor with high sensitivity and advanced circuit design technology. It features high resolution, low image distortion and low noise, etc. , which makes it suitable for surveillance system and image processing system.

- High performance CMOS sensor and high resolution bring high-quality image;
- Support IR LED;
- Support auto white balance, auto gain control,
- Unit transmission control;
- Advanced 3-axis design meets different installation requirements.

## 1.2 Overview

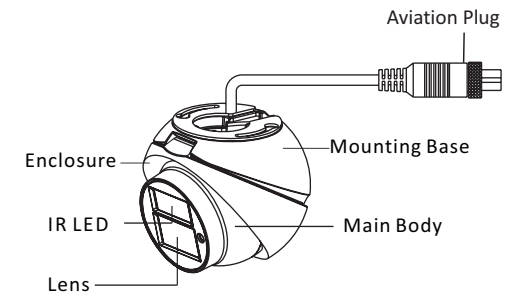

Figure 1-1 Overview

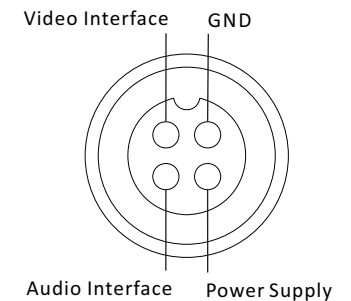

Figure 1-2 Cross Section of Aviation Plug

## 2 Installation

### Before you start:

- Please make sure that the device in the package is in good condition and all the assembly parts are included.
- Make sure that all the related equipment is power-off during the installation.
- Check the specification of the products for the installation environment.
- Check whether the power supply is matched with your power output to avoid damage.
- Please make sure the wall is strong enough to withstand three times the weight of the camera and the mounting.
- If the wall is the cement wall, you need to insert expansion screws before you install the camera. If the wall is the wooden wall, you can use self-tapping screw to secure the camera.
- If the product does not function properly, please contact your dealer or the nearest service center. Do not disassemble the camera for repair or maintenance by yourself.

### 2.1 Ceiling Mounting

#### Steps:

1. Drill the screw holes according to the drill template with  $\Phi 5.5\text{mm}$  electric drill.

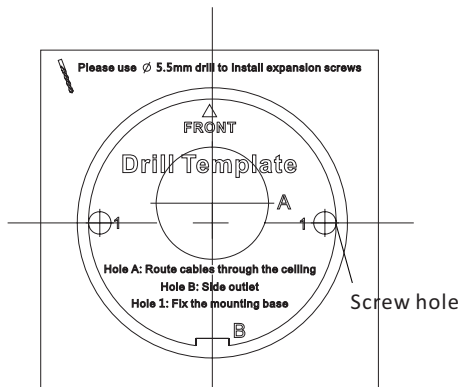

Figure 2-1 The Drill Template

2. Loosen the adjusting screw of the main body with the allen wrench.

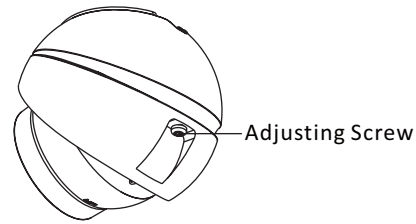

Figure 2-2 Loosen the Adjusting Screw

3. Open the enclosure to take out the camera.

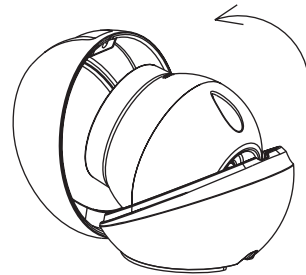

Figure 2-3 Take Out the Camera

4. Take 2 PA3X25 screws from the screw package and insert 2/3 of it into the expansion screws.

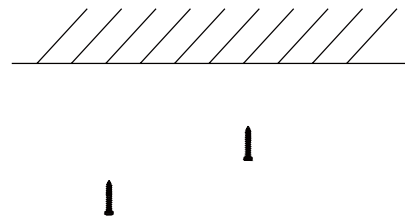

Figure 2-4 Insert the Screws

5. Align the holes of the mounting base to the PA3X25 screws.
6. Rotate the base to its appropriate position.
7. Tighten the PA3X25 screws.

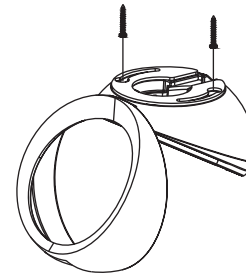

Figure 2-5 Tighten the Screws

8. Insert the main body of camera and insert the adjusting screws for 2~3 threads with allen wrench to make sure the main body doesn't fall off.
9. Adjust the main body to the appropriate position and tighten the adjusting screws.

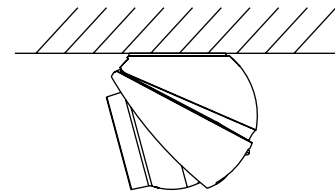

Figure 2-6 Fix the Camera

10. Adjust the camera according to the figure below to get an optimum angle.

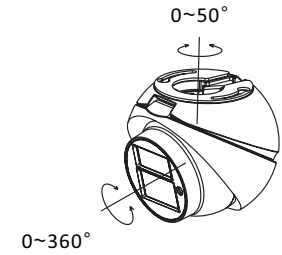
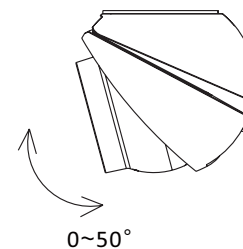

Figure 2-7 3-axis Adjustment

## 3 Appendix

### 3.1 Technical Maintenance

#### Lens Maintenance

The lens surface is plated an anti-reflection coating. The dust, oil and finger print, etc. will cause scratch, mildew and performance degraded. Please refer to the following method to clean the lens.

#### ● Handling dust

Use oil free soft brush or blowing dust ball to clean the dust.

#### ● Handling oil

#### Steps:

1. Wipe off the water-drop or oil by soft cloth and dry the lens.
2. Use oil free cotton cloth or lens clean paper to wipe the lens from center to outside with alcohol or detergent.
3. Change the cloth to wipe the lens until the lens is clean.

#### Glass Maintenance of IR Camera

#### Steps:

1. Wipe off the dust, water-drop or oil by soft cloth and dry the glass.
2. Use oil free cotton cloth or glass clean paper to wipe the glass from center to outside with alcohol or detergent.
3. Change the cloth to wipe the glass until the glass is clean.