

COMMUNICATION

issued by: **Road traffic safety directorate**

concerning¹: **APPROVAL GRANTED**
~~APPROVAL EXTENDED~~
~~APPROVAL REFUSED~~
~~APPROVAL WITHDRAWN~~
~~PRODUCTION DEFINITELY DISCONTINUED~~

of a component type pursuant to Regulation No. 118

Approval No. **E32*118RII02/04*0040*00**

Extension No.

Reason for extension: **Not applicable**

Section I

General

- 1.1. Make (trade name of manufacturer): **HIKVISION**
- 1.2. Type: **AE-VCX24X-IT**
- 1.3. Means of identification of type, if marked on the device^b: **Not applicable**
- 1.3.1. Location of that marking: **Not applicable**
- 1.4. Name and address of manufacturer: **Hangzhou Hikvision Digital Technology Co., Ltd.
No.555 Qianmo Road, Binjiang District,
Hangzhou City, Zhejiang Province,
P.R. China**
- 1.5. Location of the approval mark: **Sticker on the camera**
- 1.6. Address(es) of assembly plant(s): **Hangzhou Hikvision Digital Technology Co., Ltd.
No.299, Qiushi Road, Tonglu Economic
Development Zone, Tonglu Country, Hangzhou,
Zhejiang, P.R. China**

¹ Strike out what does not apply (there are cases where nothing needs to be deleted, when more than one entry is applicable)

^b If the means of identification of type contains characters not relevant to describe the vehicle, component or separate technical unit types covered in this information document, such characters shall be represented in the documentation by the symbol “?” (e.g. ABC??123??).

Section II

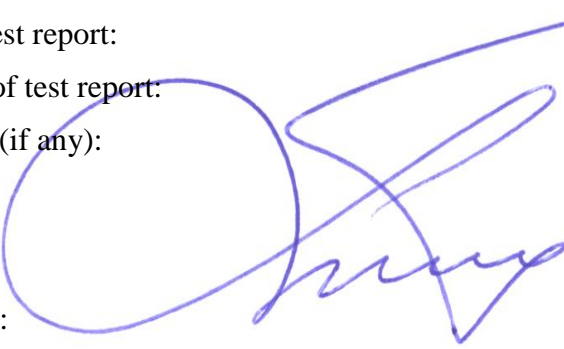
1. Additional information (where applicable): **See Appendix 1**
2. Technical Service responsible for carrying out the tests: **TŪV Rheinland-KTI Ltd.**
3. Date of test report: **01.08.2019**
4. Number of test report: **87-R118-1152/19-00**
5. Remarks (if any): **Not applicable**
6. Place: **6, S.Eizensteina St., Riga
LV-1079, Latvia**
7. Date: **09.08.2019**
8. Signature:  **Jānis Liepiņš**
9. The index to the information package lodged with the Type Approval Authority, which may be obtained on request, is attached.



Attachments: Information package. **AE-VCX24X-IT-R118-00**
Test report. **87-R118-1152/19-00, 01.08.2019**

Appendix 1

**Appendix to type approval communication form No. E32*118RII02/04*0040*00
 concerning the type approval of a component type pursuant to Regulation No. 118**

- | | | |
|--------|---|-------------------------------------|
| 1. | Additional information. | |
| 1.1. | Interior materials | |
| 1.1.1. | The direction which the component may be installed: | Not applicable |
| 1.1.2. | Fulfils the requirements in paragraph 6.2.2.: yes / not applicable ¹ | |
| 1.1.3. | Compliance has been checked for components approved as completed devices: yes / no ¹ | |
| 1.1.4. | Any restrictions of use and installation requirements: | Not applicable |
| 1.2. | Insulation materials | |
| 1.2.1. | The direction which the component may be installed: | Not applicable |
| 1.2.2. | Compliance has been checked for components approved as complete devices: yes / no ¹ | |
| 1.2.3. | Any restrictions of use and installation requirements: | Not applicable |
| 1.3. | Electric cables | |
| 1.3.1. | Any restrictions of use and installation requirements: | No |
| 2. | Remarks: | Camera with electrical cable |



¹ Strike out what does not apply.

**uniform provisions concerning the
burning behaviour and/or the capability to repel fuel or lubricant of materials used in the con-
struction of certain categories of motor vehicles**

Part II

**UN-Regulation No. 118
Amend. 02, Suppl. 4**



INFORMATION DOCUMENT

Doc.No.: AE-VCX24X-IT-R118-00

Issue Date: 2019.07.01

HIKVISION

Manufacturer : Hangzhou Hikvision Digital Technology Co., Ltd.

Type : AE-VCX24X-IT

AMENDMENT

Version	Approval No.	Modification / Correction	Date
00	---	First application	July 01, 2019

CONTENT

1 General.....3

2 Interior materials.....3

3 Insulation materials.....3

4 Electric Cables.....3

Annex 1 Drawing of Cable.....4

Annex 2 Specification of cable.....5

Annex 3 Drawing of product.....6

Annex 4 Assembly of product and material list.....8



INFORMATION DOCUMENT

Doc.No.:AE-VCX24X-IT-R118-00

Issue Date: 2019.07.01

HIKVISION

Manufacturer : Hangzhou Hikvision Digital Technology Co., Ltd.

Type : AE-VCX24X-IT

-
- 1 General
- 1.1 Make (trade name of manufacturer) : HIKVISION
- 1.2 Type and general commercial descriptions : Type: AE-VCX24X-IT
Commercial descriptions:
AE-VC024P-IT, AE-VC024N-IT, AE-VC124T-IT,
AE-VC124A-IT, AE-VC224T-IT, AE-VC224A-IT
- 1.3 Name and address of manufacturer : Hangzhou Hikvision Digital Technology Co., Ltd.
No.555 Qianmo Road, Binjiang District,
Hangzhou City, Zhejiang Province, China
- 1.4 In the case of components and separate technical units, location and method of affixing of the UN approval mark: : Stick on the camera
- 1.5 Name(s) and address(es) of assembly plant(s) : Hangzhou Hikvision Electronics Co., Ltd.
No.299, Qiushi Road, Tonglu Economic
Development Zone, Tonglu Country, Hangzhou,
Zhejiang, China
2. Interior materials : Not applicable
3. Insulation Materials : Not applicable
4. Electric Cables
- 4.1. Material(s) used for : Camera
- 4.2. Base material(s)/designation : See Annex 1 and Annex 2
- 4.3. Composite/single material, number of layers : See Annex 2
- 4.4. Type of coating : Not applicable
- 4.5. Maximum/minimum thickness : See Annex 2
- 4.6. Type approval number, if available : Not applicable



HIKVISION

Manufacturer : Hangzhou Hikvision Digital Technology Co., Ltd.

Type : AE-VCX24X-IT

Annex 1 Drawing of Cable

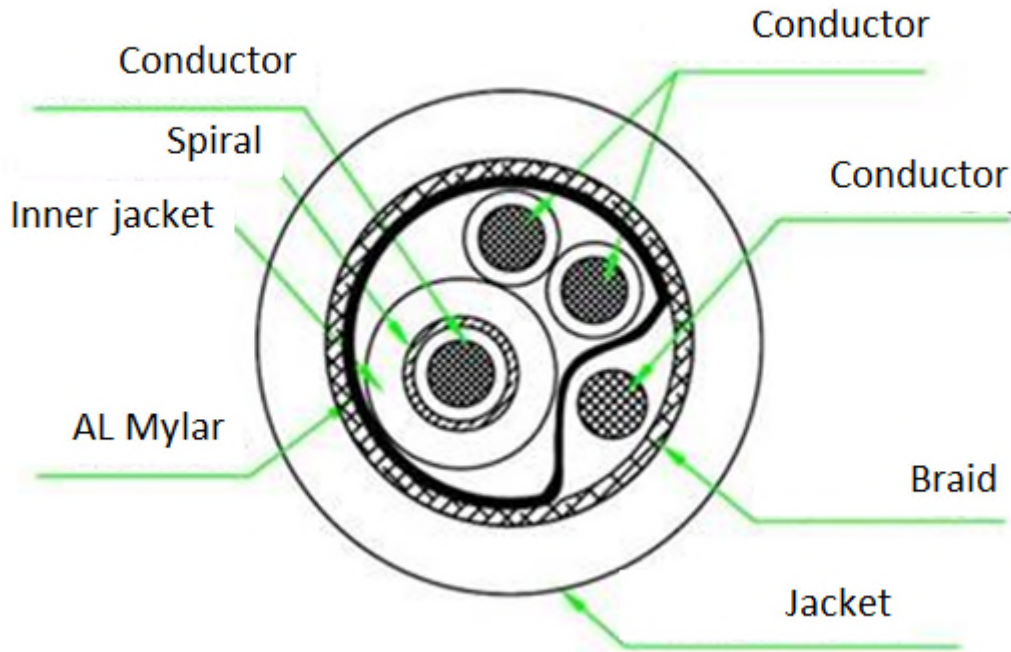

HIKVISION

Manufacturer : Hangzhou Hikvision Digital Technology Co., Ltd.

Type : AE-VCX24X-IT

Annex 2 Specification of cable

P/N		SPECIFICATION	
ITEM		SPECIFICATION	
CONDUCTOR	AWG	28#	
	MATERIAL	TC	
	COND.SIZE	7/0.127	
INSULATION	MIN.AVG.THICK	0.34MM	
	MATERIAL	PVC	
	O.D	0.9MM	
	NO.	2	
AL.Mylar	COVERAGE	100%	
	OVERLAP	25%	
Filler	MATERIAL	/	
LAY	LAY	TC	
Jacket	MIN.AVG.THICK	0.4MM	
	MATERIAL	PVC	
	COLOR	BK	
	O.D	4.8	



HIKVISION

Manufacturer : Hangzhou Hikvision Digital Technology Co., Ltd.

Type : AE-VCX24X-IT

Annex 3 Drawing of product

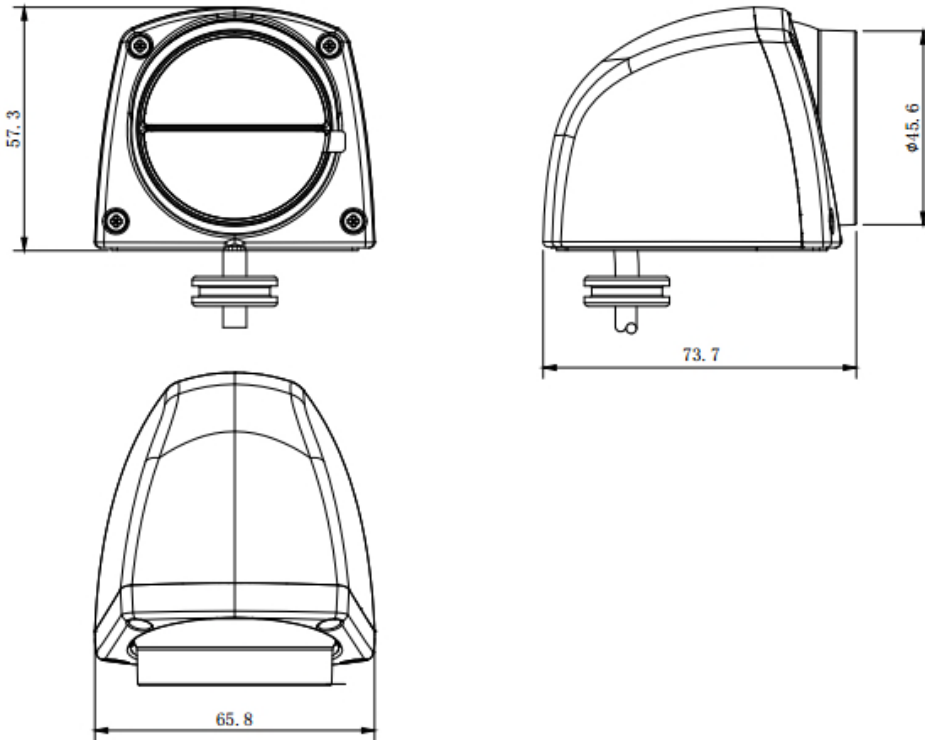

HIKVISION

Manufacturer : Hangzhou Hikvision Digital Technology Co., Ltd.

Type : AE-VCX24X-IT

HIKVISION

COLOR CAMERA

Model: AE-VCX24X-IT

IP: DC12V=3W MAX



SN: ABCDEFGHI

01/2019

Manufacturer: Hangzhou Hikvision Digital Technology Co.,Ltd

Address: No.555 Qianmo Road, Binjiang District, Hangzhou 310052, China



Made in China

CAN ICES-3 (A)/NMB-3(A)

E mark Convention



a >= 8mm

Location of approval mark: Stick on the camera



HIKVISION

Manufacturer : Hangzhou Hikvision Digital Technology Co., Ltd.

Type : AE-VCX24X-IT

Annex 4 Assembly of product and material list

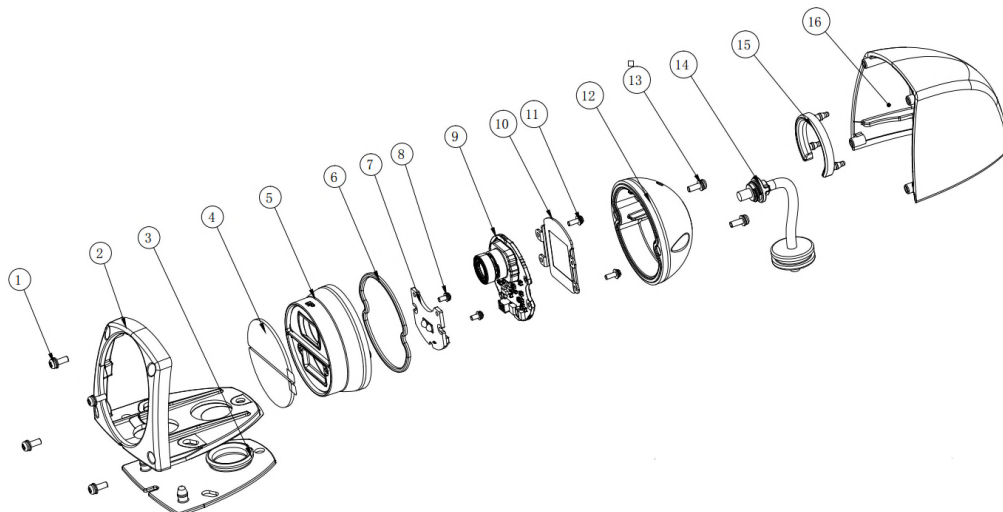

1	Screw	SUS304	4
2	metal cover	ADC12	1
3	Spacer	Silica gel	1
4	Lens cover	PMMA+PC	1
5	metal cover	ADC12	1
6	Sealing ring	Silica gel	1
7	PCBA	/	1
8	Screw	Carbon steel	2
9	PCBA	/	1
10	Sheet metal	Aluminum alloy 6061	1
11	Screw	SUS304	2
12	Rear cover	ADC12	1
13	Screw	SUS304	2
14	Video line	/	1
15	Spacer	Silica gel	1
16	Rear cover	ADC12	1

Remark: The plastic materials in the camera are not possible to extract a sample in the prescribed dimensions as specified in Annex 6, Annex 7 and Annex 8.



Type : AE-VCX24X-IT
Manufacturer : Hangzhou Hikvision Digital Technology Co., Ltd.

Precisely Right.

TEST REPORT

according to UN-Regulation

Uniform provisions concerning the Burning Behaviour and/ or the capability to repel fuel or lubricant of materials used in the construction of certain categories of motor vehicles

Part II — Approval of a component with regard to its burning behaviour and/or its capability to repel fuel or lubricant installed in the interior compartment, the engine compartment or any separate heating compartment

UN-Regulation No. 118

as last amended by

Amend. 02, Suppl. 4

Previously granted

UN approval : --

Structure of the Test Report

Item No.

0. General information
 1. Tested vehicle(s) / object(s)
 2. Test record
 3. Remark concerning tested object(s)
 4. List of appendices
 5. Statement of conformity
-

The Test Report shall be reproduced and published in full by the client only. It shall however be reproduced partially with the written permission of the Technical Service only.



Type : AE-VCX24X-IT
Manufacturer : Hangzhou Hikvision Digital Technology Co., Ltd.

0. General information

- 0.1. Make (trade name of the manufacturer) : HIKVISION
- 0.2. Type : AE-VCX24X-IT
- 0.3. Category of vehicle : n.a.
- 0.4. Name and address of the manufacturer : Hangzhou Hikvision Digital Technology Co., Ltd.
No.555 Qianmo Road, Binjiang District,
Hangzhou City, Zhejiang Province, China
- 0.5. No. of the information folder : AE-VCX24X-IT-R118-00
 - Date of issue : July 01, 2019
 - Date of last change : ---

1. Tested vehicle(s)/ object(s)

- 1.1. Description
- 1.1.1. ~~Vehicle~~ / object : [~~Vehicle~~] [Object]
- Commercial description : AE-VC024P-IT, AE-VC024N-IT, AE-VC124T-IT,
AE-VC124A-IT, AE-VC224T-IT, AE-VC224A-IT
- Type(s) / ~~variant(s)~~ / ~~version(s)~~ : AE-VCX24X-IT
- Identification number : n.a.
- 1.1.2. Condition of ~~vehicle(s)~~ / Object(s) : New / ~~used~~ / ~~pretested~~
- 1.2. Worst case selection : The determination of worst case was done according to internal procedure of the Technical Service (QMA 1.301.005, section 6.2.2.2)
- 1.3. Remarks : All versions of the ~~vehicle~~ / object type as stated in the information folder are covered by the ~~tested vehicle version(s)~~ and tested object(s) respectively.

Type : AE-VCX24X-IT
 Manufacturer : Hangzhou Hikvision Digital Technology Co., Ltd.

2. Test record

- 2.1. Equipment for measuring and testing : The test facilities / measurement equipment used were in compliance with the test requirements.
- 2.1.1. Specifications for the test site : n.a.
- 2.1.2. Subcontracting : n.a.
- 2.2. Test results : Passed /~~failed~~
- 2.2.1. Horizontal burning behaviour : n.a.
- 2.2.2. Melting behaviour : n.a.
- 2.2.3. Vertical burning behavior : n.a.
- 2.2.4. Complete device : The complete device includes electrical cable and camera. The surface area of each element on camera made of non-metal is less than 300 cm², so the camera is not required to undergo the tests of horizontal burning test, vertical burning test or melting behaviour test.
- 2.2.5. Repel fuel or lubricant : n.a.
- 2.2.6. Flame propagation test for electric cable : Flame is extinguish within 70s and not less than 50mm insulation at the top of the test sample is remain unburned.
- 2.2.7. Mark with trade name and type : The samples are clearly and indelibly marked with the applicant's trade name and the type designation.
- 2.2.8. Alternative test provisions : n.a.
- 2.2.9. Attributive tests : n.a.
- Remark concerning extension : ~~The type has been tested according to the modification(s) mentioned in appendix 0-~~
~~The new parts meet the requirements of the regulation / directive.~~
 An actual practical test of the type was not necessary. The results of the previous test(s) are still valid.
- 2.3. Additional information : The results of the test refer exclusively to the object(s) mentioned under point 1.1. of this report.
- Test site : Automotive Component Testing Center of Ningbo
 No. 99, Jingu South Road, Yinzhou Investment & Business Incubation, 315104, Ningbo, P.R. China
- Test date : July 19, 2019
- 2.4. Remarks : --

Type : AE-VCX24X-IT
Manufacturer : Hangzhou Hikvision Digital Technology Co., Ltd.

3. **Remark concerning tested object(s)** : All versions of the type as stated in the information document are covered with the tested version(s) and test object(s) respectively.

4. **List of Appendices**

Appendix 0 : List of modifications

Appendix 1 : Test result

Information folder no. : AE-VCX24X-IT-R118-00

5. **Statement of conformity**

The in point 0.5. mentioned information folder and the type described in that comply with the requirements mentioned on page 1.

With regard to the required level of performance to be achieved, the tested items were representative for the type to be approved (see point 1.2).

The mentioned test results refer to the ~~vehicle(s)~~ object(s) described under point 1.1 of this report.

Engineering centre Shanghai / August 1, 2019



Emma Yu
Expert Technical Service

Type : AE-VCX24X-IT
Manufacturer : Hangzhou Hikvision Digital Technology Co., Ltd.

Appendix 0

List of modifications

Correction of : ---

Modification of : ---

Addition of : ---

Deletion of : ---



Type : AE-VCX24X-IT
 Manufacturer : Hangzhou Hikvision Digital Technology Co., Ltd.

Precisely Right.

Test result

Appendix 1

Flame propagation test for electric cable

Specimen	Dimension (mm)	Burning duration (s)	Unburnt length at the top (mm)	Remark
1	> 600	3.7	> 50	--
2	> 600	1.2	> 50	--
3	> 600	3.6	> 50	--
4	> 600	4.0	> 50	--
5	> 600	4.1	> 50	--