

## COMMUNICATION

issued by: **Road traffic safety directorate**

concerning<sup>1</sup>: ~~APPROVAL GRANTED~~  
APPROVAL EXTENDED  
~~APPROVAL REFUSED~~  
~~APPROVAL WITHDRAWN~~  
~~PRODUCTION DEFINITELY DISCONTINUED~~

of a component type pursuant to Regulation No. 118

Approval No. **E32\*118RII03/01\*0046\*01** Extension No. **01**Reason for extension: **Addition of new commercial description**

## Section I

## General

- 1.1. Make (trade name of manufacturer): **HIKVISION**
- 1.2. Type: **DS-2XM63X5G0-IVM**
- 1.3. Means of identification of type, if marked on the device<sup>b</sup>: **Not applicable**
- 1.3.1. Location of that marking: **Not applicable**
- 1.4. Name and address of manufacturer: **Hangzhou Hikvision Digital Technology Co., Ltd.  
No.555 Qianmo Road, Binjiang District,  
Hangzhou City, Zhejiang Province,  
P.R. China**
- 1.5. Location of the approval mark: **Sticker on the camera**
- 1.6. Address(es) of assembly plant(s): **Hangzhou Hikvision Digital Technology Co., Ltd.  
No.555 Qianmo Road, Binjiang District,  
Hangzhou City, Zhejiang Province,  
P.R. China**

<sup>1</sup> Strike out what does not apply (there are cases where nothing needs to be deleted, when more than one entry is applicable)

<sup>b</sup> If the means of identification of type contains characters not relevant to describe the vehicle, component or separate technical unit types covered in this information document, such characters shall be represented in the documentation by the symbol “?” (e.g. ABC??123??).

Section II

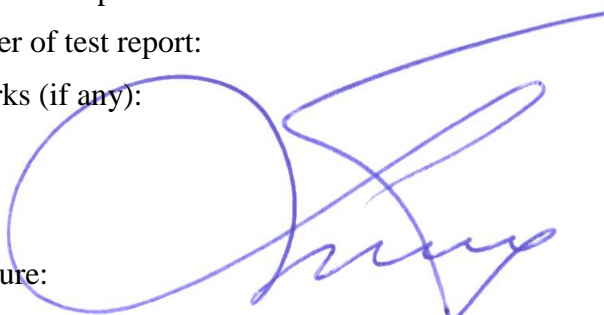
1. Additional information (where applicable): **See Appendix 1**
2. Technical Service responsible for carrying out the tests: **TŪV Rheinland-KTI Ltd.**
3. Date of test report: **18.12.2019**
4. Number of test report: **87-R118-1890/19-00**
5. Remarks (if any): **Not applicable**
6. Place: **6, S.Eizensteina St., Riga  
LV-1079, Latvia**
7. Date: **10.01.2020**
8. Signature:  **Jānis Liepiņš**
9. The index to the information package lodged with the Type Approval Authority, which may be obtained on request, is attached.



Attachments: Information package. **DS-2XM63X5G0-IVM-R118-01**  
Test report. **87-R118-1890/19-00, 18.12.2019**

### Appendix 1

**Appendix to type approval communication form No. E32\*118R1103/01\*0046\*01  
 concerning the type approval of a component type pursuant to Regulation No. 118**

- |        |   |                                     |
|--------|---|-------------------------------------|
| 1.     | Additional information.   |                                     |
| 1.1.   | Interior materials  |                                     |
| 1.1.1. | The direction which the component may be installed:   | <b>Not applicable</b>               |
| 1.1.2. | Fulfils the requirements in paragraph 6.2.2.: <del>yes</del> / <b>not applicable</b> <sup>1</sup>                 |                                     |
| 1.1.3. | Compliance has been checked for components approved as completed devices: <del>yes</del> / <b>no</b> <sup>1</sup> |                                     |
| 1.1.4. | Any restrictions of use and installation requirements:  | <b>Not applicable</b>               |
| 1.2.   | Insulation materials  |                                     |
| 1.2.1. | The direction which the component may be installed:   | <b>Not applicable</b>               |
| 1.2.2. | Compliance has been checked for components approved as complete devices: <del>yes</del> / <b>no</b> <sup>1</sup>  |                                     |
| 1.2.3. | Any restrictions of use and installation requirements:  | <b>Not applicable</b>               |
| 1.3.   | Electric cables   |                                     |
| 1.3.1. | Any restrictions of use and installation requirements:  | <b>No</b>                           |
| 2.     | Remarks:  | <b>Camera with electrical cable</b> |



<sup>1</sup> Strike out what does not apply.

**uniform provisions concerning the  
burning behaviour and/or the capability to repel fuel or lubricant of materials used in the con-  
struction of certain categories of motor vehicles**

**Part II**

**UN-Regulation No. 118  
Amend. 03, Suppl. 1**



# INFORMATION DOCUMENT

Doc. No.: DS-2XM63X5G0-IVM-R118-01

Issue Date: December 11, 2019

**HIKVISION**

Manufacturer : Hangzhou Hikvision Digital Technology Co., Ltd.

Type : DS-2XM63X5G0-IVM

## AMENDMENT

Version	Approval No.	Modification / Correction	Date
00	E32*118RII03/01*0046*00	First application	July 30, 2019
01	<u>E32*118RII03/01*0046*01</u>	<u>Extension application</u>	<u>December 11, 2019</u>

## CONTENT

1	General.....	3
2	Interior materials.....	3
3	Insulation materials.....	3
4	Electric Cables.....	3
	Annex 1 Drawing of Cable.....	4
	Annex 2 Specification of cable.....	7
	Annex 3 Drawing of product.....	8
	Annex 4 Assembly of product and material list.....	10



## INFORMATION DOCUMENT

Doc. No.: DS-2XM63X5G0-IVM-R118-01

Issue Date: December 11, 2019

### HIKVISION

Manufacturer : Hangzhou Hikvision Digital Technology Co., Ltd.

Type : DS-2XM63X5G0-IVM

---

- 1 General
- 1.1 Make (trade name of manufacturer) : HIKVISION
- 1.2 Type and general commercial descriptions : Type: DS-2XM63X5G0-IVM  
Commercial descriptions:  
DS-2XM63C5G0-IVM, DS-2XM6365G0-IVM,  
DS-2XM6825G0/C-IVSM
- 1.3 Name and address of manufacturer : Hangzhou Hikvision Digital Technology Co., Ltd.  
No.555 Qianmo Road, Binjiang District,  
Hangzhou City, Zhejiang Province, China
- 1.4 In the case of components and separate technical units, location and method of affixing of the UN approval mark: : Stick on the camera
- 1.5 Name(s) and address(es) of assembly plant(s) : Same as 1.3
2. Interior materials : Not applicable
3. Insulation Materials : Not applicable
4. Electric Cables
- 4.1. Material(s) used for : Camera
- 4.2. Base material(s)/designation : See Annex 1 and Annex 2
- 4.3. Composite/single material, number of layers : See Annex 2
- 4.4. Type of coating : Not applicable
- 4.5. Maximum/minimum thickness : See Annex 2
- 4.6. Type approval number, if available : Not applicable



HIKVISION

Manufacturer : Hangzhou Hikvision Digital Technology Co., Ltd.

Type : DS-2XM63X5G0-IVM

Annex 1 Drawing of Cable

1. UL20789 28AWG/2P+AL/MY+BRAID+JACKET

*Cable1*

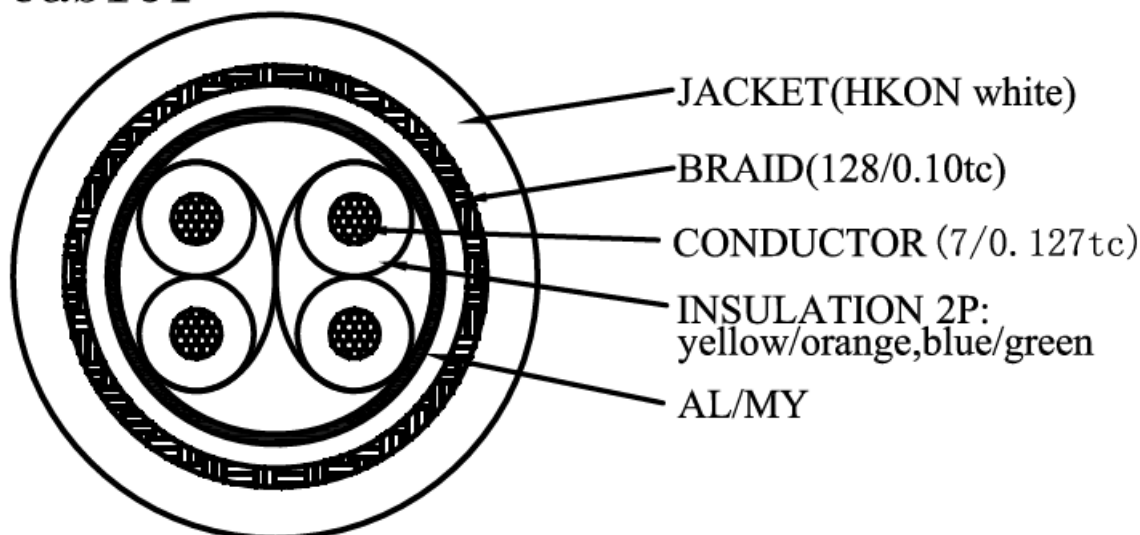

2. UL20789 26AWG/2C+JACKET

*Cable2*

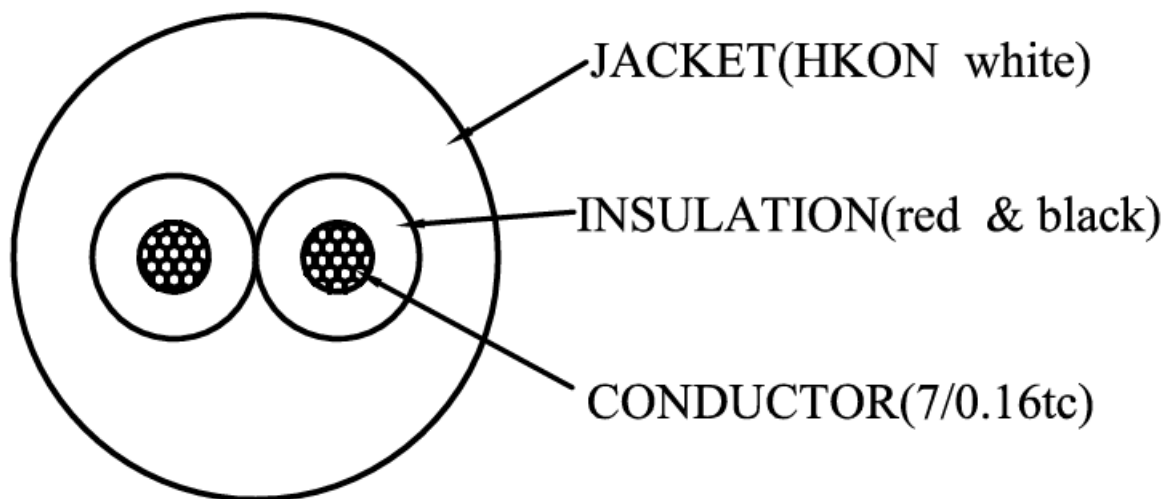

INFORMATION DOCUMENT

Doc. No.: DS-2XM63X5G0-IVM-R118-01

Issue Date: December 11, 2019

HIKVISION

Manufacturer : Hangzhou Hikvision Digital Technology Co., Ltd.

Type : DS-2XM63X5G0-IVM

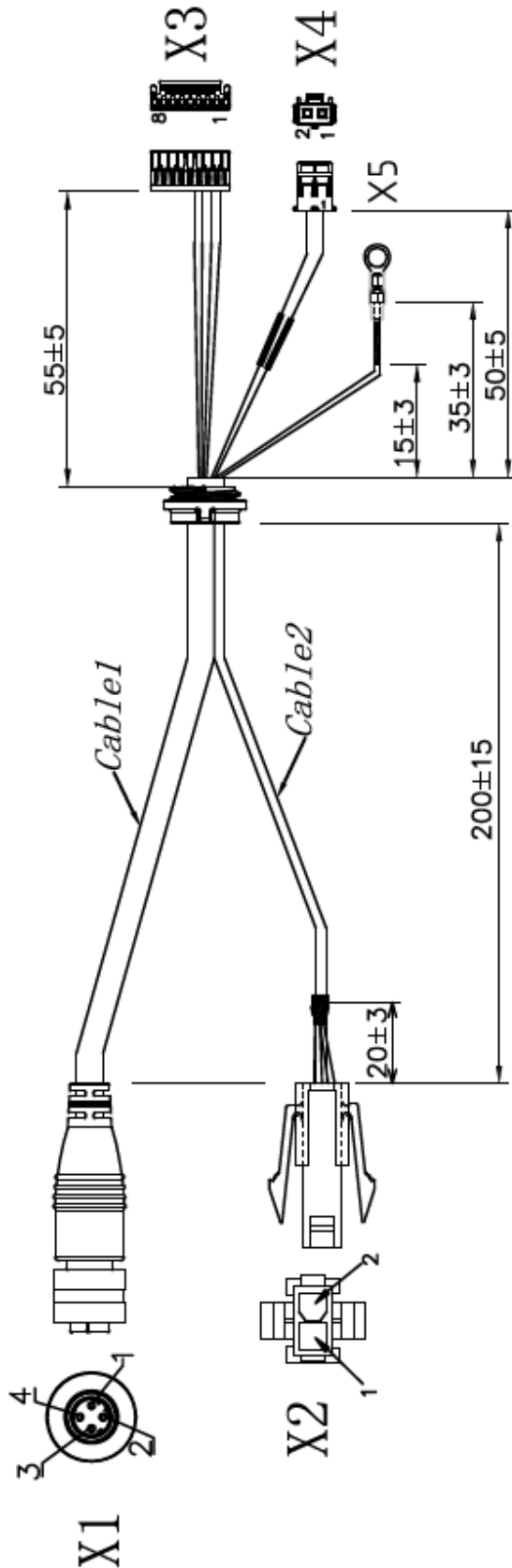

Production Dimensions





**HIKVISION**

Manufacturer : Hangzhou Hikvision Digital Technology Co., Ltd.

Type : DS-2XM63X5G0-IVM

### (2) Connect

X1	p1	p2	p3	p4	Shell
Wire	Tiny	Tiny	Tiny	Tiny	Large
Color	ORANGE	GREEN	YELLOW	BLUE	/
Standard	7/0.127TC	7/0.127TC	7/0.127TC	7/0.127TC	BRAID

X2	p1	p2
Wire	Large	Large
Color	RED	BLACK
Standard	7/0.16TC	7/0.16TC

X3	p1	p2	p3	p4	p5	p6	p7	p8
Wire	Tiny	Tiny	Tiny	Tiny	/	/	/	/
Color	ORANGE	YELLOW	GREEN	BLUE	N/C	N/C	N/C	N/C
Standard	7/0.127TC	7/0.127TC	7/0.127TC	7/0.127TC	/	/	/	/

X4	p1	p2
Wire	Large	Large
Color	RED	BLACK
Standard	7/0.16TC	7/0.16TC

X5	GND
Wire	Large
Color	BLACK
Standard	BRAID

### (3) Front view of connector

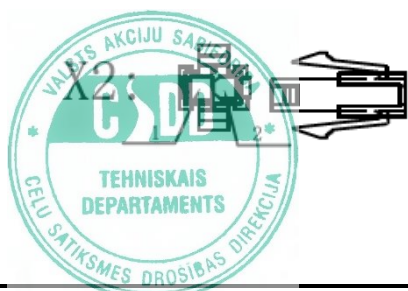
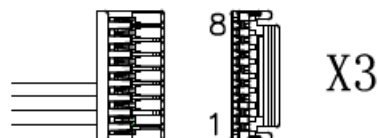
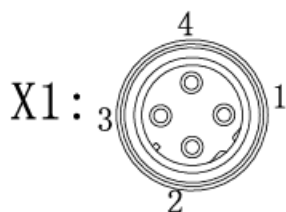

**HIKVISION**

Manufacturer : Hangzhou Hikvision Digital Technology Co., Ltd.

Type : DS-2XM63X5G0-IVM

**Annex 2 Specification of cable**

**1. UL20789 28AWG/2P+AL/MY+BRAID+JACKET**

SPECIFICATION		UL20789 28AWG/2P+AL/MY+BRAID+JACKET
ITEM		SPECIFICATION
CONDUCTOR	AWG	28AWG
	MATERIAL	TINNED COPPER
	COND.SIZE	7/0.127±0.008mm
INSULATION	AVG.THICK	0.23mm
	MATERIAL	SR-PVC
	OD	0.90±0.05mm
SHIELD	MATERIAL	AL/MY(Face Outside)
	COVERAGE	100%
	OVERLAP	25%
BRAID	MATERIAL	TINNED COPPER
	COND.SIZE	16/8/0.10±0.008mm
	COVERAGE	≥85%
JACKET	AVG.THICK	0.50mm
	MATERIAL	105℃ 80P/PVC
	COLOR	HK16白
	OD	4.80±0.20mm

**2. UL20789 26AWG/2C+JACKET**

SPECIFICATION		UL20789 26AWG/2C+JACKET
ITEM		SPECIFICATION
CONDUCTOR	AWG	26AWG
	MATERIAL	TINNED COPPER
	COND.SIZE	7/0.16±0.008mm
INSULATION	AVG.THICK	0.23mm
	MATERIAL	SR-PVC
	OD	1.00±0.05mm
JACKET	AVG.THICK	0.50mm
	MATERIAL	80℃ 60P/PVC
	COLOR	HK16白
	OD	3.00±0.10mm



**HIKVISION**

Manufacturer : Hangzhou Hikvision Digital Technology Co., Ltd.

Type : DS-2XM63X5G0-IVM

**Annex 3 Drawing of product**

XM63:

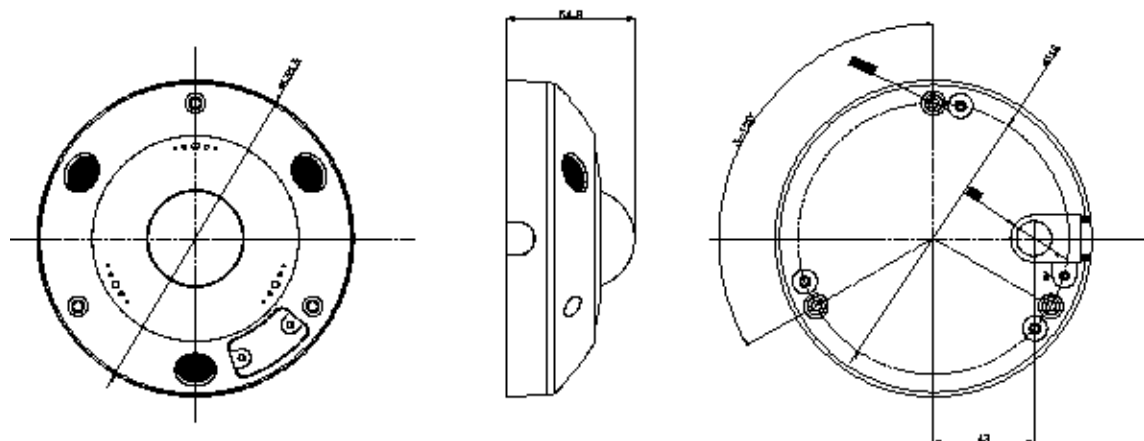

XM68:

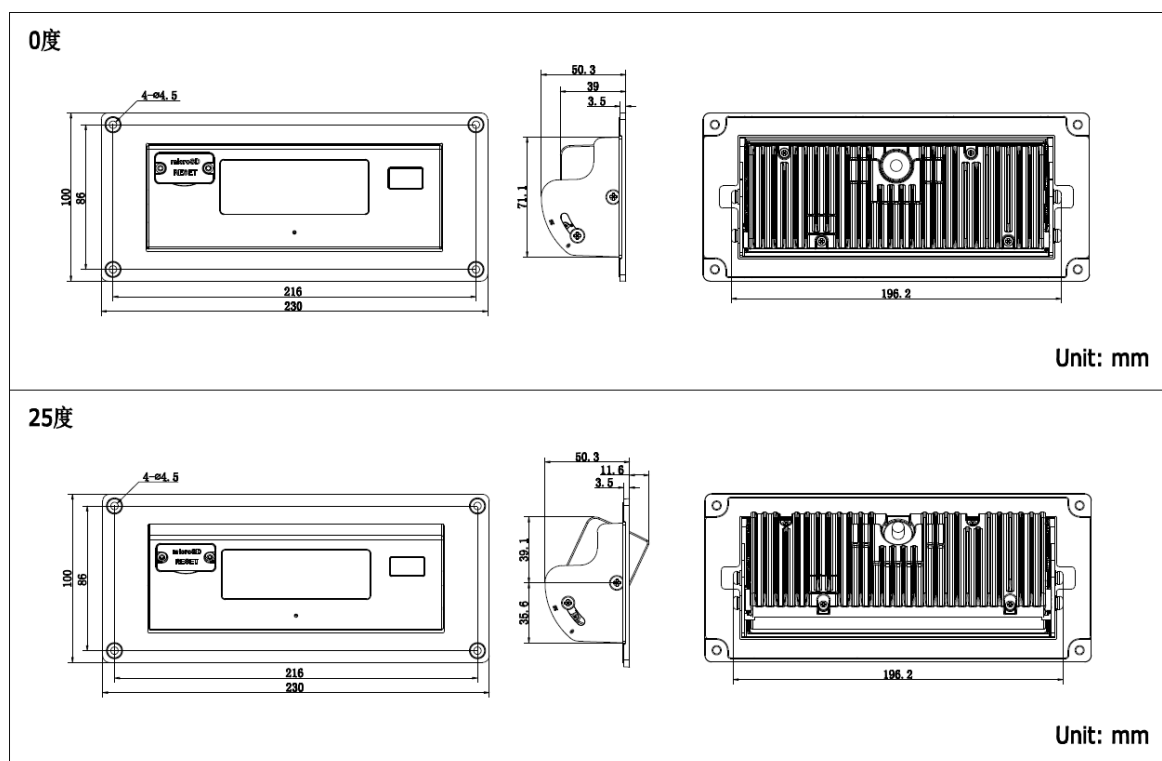

HIKVISION

Manufacturer : Hangzhou Hikvision Digital Technology Co., Ltd.

Type : DS-2XM63X5G0-IVM

HIKVISION

NETWORK CAMERA

Model: DS-2XM63X5G0-IVM

SN: SV:



IP: 24V=0.3A,9W

PoE(802.3af,36-57V)=0.25-0.15A

MAC Address: 58:03:FB:2F:FF:FE

Manufacturer: Hangzhou Hikvision Digital Technology Co.,Ltd.

Address: No.555 Qianmo Road, Binjiang District, Hangzhou 310052, China



Made in China

E mark Convention

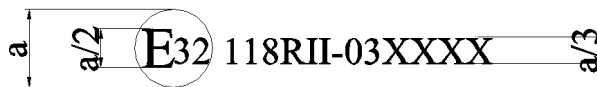

a ≥ 8 mm

Location of approval mark: Stick on the camera

XM63:



XM68:



**HIKVISION**

Manufacturer : Hangzhou Hikvision Digital Technology Co., Ltd.

Type : DS-2XM63X5G0-IVM

**Annex 4 Assembly of product and material list**

XM63:

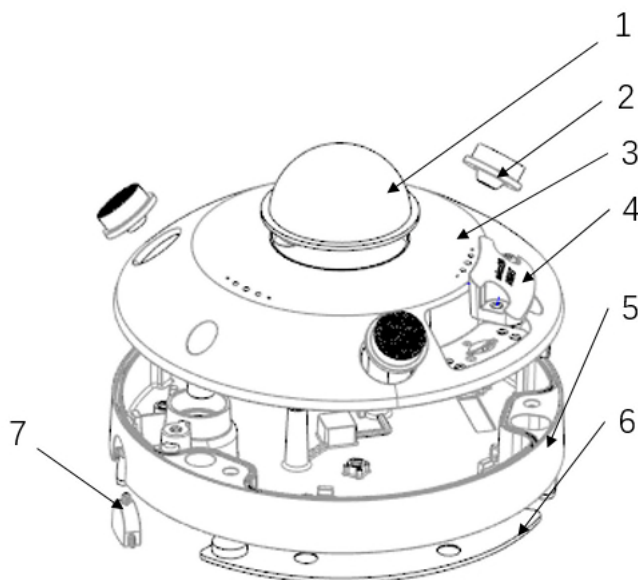

No.	Name	Material	Quantity
1	Lens guard	PC	1
2	LENS	PC	3
3	Top housing	ADC12	1
4	SD cover	ADC12	1
5	Bot housing	ADC12	1
6	Shock Pad	Silica gel	1
7	Sider cover	PC	1



# INFORMATION DOCUMENT

Doc. No.: DS-2XM63X5G0-IVM-R118-01

Issue Date: December 11, 2019

**HIKVISION**

Manufacturer : Hangzhou Hikvision Digital Technology Co., Ltd.

Type : DS-2XM63X5G0-IVM

XM68:

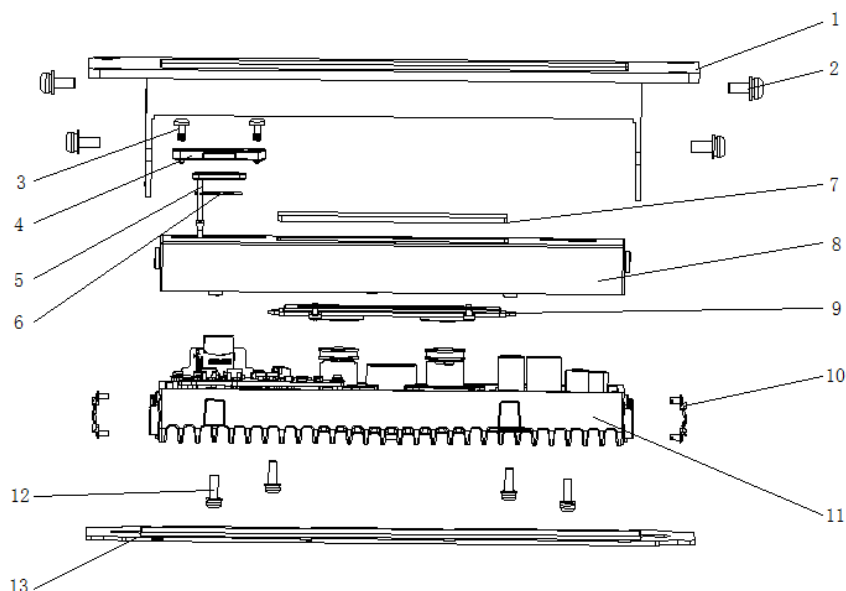

No.	Name	Material	Quantity
1	Recessed Ceiling Mount	ADC12	1
2	SCREW-1	SUS304	4
3	SCREW-2	SUS304	2
4	SD cover	ADC12	1
5	Seal ring	Silica gel	1
6	Seal ring plate	SUS304	1
7	camera window	PC	1
8	UP COVER	ADC12	1
9	Decorative Cover	PC	1
10	elastic pad	SUS301	2
11	BOT	ADC12	1
12	SCREW-3	SUS304	4
13	Silicone Cushion	Silica gel	1

Remark: The plastic materials in the camera are not possible to extract a sample in the prescribed dimensions as specified in Annex 6, Annex 7 and Annex 8.





Type : DS-2XM63X5G0-IVM  
Manufacturer : Hangzhou Hikvision Digital Technology Co., Ltd.

---

Precisely Right.

## TEST REPORT

according to UN-Regulation

**Uniform provisions concerning the Burning Behaviour and/ or the capability to repel fuel or lubricant of materials used in the construction of certain categories of motor vehicles**

**Part II — Approval of a component with regard to its burning behaviour and/or its capability to repel fuel or lubricant installed in the interior compartment, the engine compartment or any separate heating compartment**

**UN-Regulation No. 118**

as last amended by

**Amend. 03, Suppl. 1**

---

Previously granted

UN approval : E32\*118R1103/01\*0046\*00

---

Structure of the Test Report

Item No.

0. General information
  1. Tested vehicle(s) / object(s)
  2. Test record
  3. Remark concerning tested object(s)
  4. List of appendices
  5. Statement of conformity
- 

The Test Report shall be reproduced and published in full by the client only. It shall however be reproduced partially with the written permission of the Technical Service only.



Type : DS-2XM63X5G0-IVM  
 Manufacturer : Hangzhou Hikvision Digital Technology Co., Ltd.

## 0. General information

- 0.1. Make (trade name of the manufacturer) : HIKVISION
- 0.2. Type : DS-2XM63X5G0-IVM
- 0.3. Category of vehicle : n.a.
- 0.4. Name and address of the manufacturer : Hangzhou Hikvision Digital Technology Co., Ltd.  
 No.555 Qianmo Road, Binjiang District,  
 Hangzhou City, Zhejiang Province, China
- 0.5. No. of the information folder : DS-2XM63X5G0-IVM-R118-01  
 - Date of issue : December 11, 2019  
 - Date of last change : --

## 1. Tested vehicle(s)/ object(s)

- 1.1. Description
- 1.1.1. ~~Vehicle~~ / object : ~~{Vehicle}~~ [Object]  
 Commercial description : DS-2XM63C5G0-IVM, DS-2XM6365G0-IVM,  
DS-2XM6825G0/C-IVSM  
 Type(s) / ~~variant(s)~~ / ~~version(s)~~ : DS-2XM63X5G0-IVM  
 Identification number : n.a.
- 1.1.2. Condition of ~~vehicle(s)~~ / Object(s) : New / ~~used~~ / ~~pre-tested~~
- 1.2. Worst case selection : The determination of worst case was done according to internal procedure of the Technical Service (QMA 1.301.005, section 6.2.2.2)
- 1.3. Remarks : All versions of the ~~vehicle~~ / object type as stated in the information folder are covered by the ~~tested vehicle version(s)~~ and tested object(s) respectively.





Type : DS-2XM63X5G0-IVM  
 Manufacturer : Hangzhou Hikvision Digital Technology Co., Ltd.

## 2. Test record

- 2.1. Equipment for measuring and testing : The test facilities / measurement equipment used were in compliance with the test requirements.
- 2.1.1. Specifications for the test site : n.a.
- 2.1.2. Subcontracting : n.a.
- 2.2. Test results : Passed /~~failed~~
- 2.2.1. Horizontal burning behaviour : n.a.
- 2.2.2. Melting behaviour : n.a.
- 2.2.3. Vertical burning behavior : n.a.
- 2.2.4. Complete device : The complete device includes electrical cable and camera. The surface area of each element on camera made of non-metal is less than 300 cm<sup>2</sup>, so the camera is not required to undergo the tests of horizontal burning test, vertical burning test or melting behaviour test.
- 2.2.5. Repel fuel or lubricant : n.a.
- 2.2.6. Flame propagation test for electric cable : Flame is extinguish within 70s and not less than 50mm insulation at the top of the test sample is remain unburned.
- 2.2.7. Mark with trade name and type : The samples are clearly and indelibly marked with the applicant's trade name and the type designation.
- 2.2.8. Alternative test provisions : n.a.
- 2.2.9. Attributive tests : n.a.
- Remark concerning extension : ~~The type has been tested according to the modification(s) mentioned in appendix 0.~~  
~~The new parts meet the requirements of the regulation / directive.~~  
An actual practical test of the type was not necessary. The results of the previous test(s) are still valid.
- 2.3. Additional information : The results of the test refer exclusively to the object(s) mentioned under point 1.1. of this report.
- Test site : Automotive Component Testing Center of Ningbo  
 No. 99, Jingu South Road, Yinzhou Investment & Business Incubation, 315104, Ningbo, P.R. China
- Test date : July 19, 2019
- 2.4. Remarks : --



Type : DS-2XM63X5G0-IVM  
Manufacturer : Hangzhou Hikvision Digital Technology Co., Ltd.

---

3. **Remark concerning tested object(s)** : All versions of the type as stated in the information document are covered with the tested version(s) and test object(s) respectively.

4. **List of Appendices**

Appendix 0 : List of modifications  
Appendix 1 : Test result  
Information folder no. : DS-2XM63X5G0-IVM-R118-01

5. **Statement of conformity**

The in point 0.5. mentioned information folder and the type described in that comply with the requirements mentioned on page 1.

With regard to the required level of performance to be achieved, the tested items were representative for the type to be approved (see point 1.2).

The mentioned test results refer to the ~~vehicle(s)~~ object(s) described under point 1.1 of this report.

Engineering centre Shanghai / December 18, 2019

EY



Emma Yu  
Expert Technical Service



Type : DS-2XM63X5G0-IVM  
Manufacturer : Hangzhou Hikvision Digital Technology Co., Ltd.

---

Precisely Right.

Appendix 0

List of modifications

- Correction of : ---
  
- Modification of : ---
  
- Addition of : new commercial description
  
- Deletion of : ---



Type : DS-2XM63X5G0-IVM  
 Manufacturer : Hangzhou Hikvision Digital Technology Co., Ltd.

## Test result

## Appendix 1

## Flame propagation test for electric cable

## Cable 1

Specimen	Dimension (mm)	Burning duration (s)	Unburnt length at the top (mm)	Remark
1	> 600	9.0	> 50	--
2	> 600	10.3	> 50	--
3	> 600	6.3	> 50	--
4	> 600	11.4	> 50	--
5	> 600	13.0	> 50	--

## Cable 2

Specimen	Dimension (mm)	Burning duration (s)	Unburnt length at the top (mm)	Remark
1	> 600	0.7	> 50	--
2	> 600	1.2	> 50	--
3	> 600	0.9	> 50	--
4	> 600	0.8	> 50	--
5	> 600	1.1	> 50	--

