

Test Report

No. AJFS1912013726FF

Date: JAN.20, 2020

Page 1 of 14

HANGZHOU HIKVISION DIGITAL TECHNOLOGY CO., LTD

NO.555, QIANMO ROAD, BINJIANG DISTRICT, HANGZHOU, 310052, CHINA

The following sample(s) was / were submitted and identified on behalf of the client. SGS is not responsible for the authenticity, integrity and results of the data and information and / or the validity of the conclusion. results apply to the sample as received.

Sample Description: NETWORK CAMERA

SGS Ref No.: SHES1912028993TX

Trade Mark: HIKVISION

Model No.: DS-2XM6522G0-ID

Country of Origin: MADE IN CHINA

TEST(S) REQUESTED:

Assessment on the fire performance of "Compliant HL3", which defined in EN 45545-2:2013+A1:2015 Railway applications—Fire protection on railway vehicles Part 2: Requirements for fire behaviour of materials and components, for the "NETWORK CAMERA, Model No.: DS-2XM6522G0-ID"

TEST RESULT(S): -- See attached sheet --

Test Period:

Sample Receiving Date : DEC.26, 2019

Test Performing Date : DEC.26, 2019 TO JAN.14, 2020

Signed for and on behalf of
SGS-CSTC Co., Ltd. Anji Branch



Allen Zou
Lab Manager

scan to see the report



AJFS1912013726FF



Unless otherwise agreed in writing, this document is issued by the Company subject to its General Conditions of Service printed overleaf, available on request or accessible at <http://www.sgs.com/en/Terms-and-Conditions.aspx> and, for electronic format documents, subject to Terms and Conditions for Electronic Documents at <http://www.sgs.com/en/Terms-and-Conditions/Terms-e-Documents.aspx>. Attention is drawn to the limitation of liability, indemnification and jurisdiction issues defined therein. Any holder of this document is advised that information contained hereon reflects the Company's findings at the time of its intervention only and within the limits of Client's instructions, if any. The Company's sole responsibility is to its Client and this document does not exonerate parties to a transaction from exercising all their rights and obligations under the transaction documents. This document cannot be reproduced except in full, without prior written approval of the Company. Any unauthorized alteration, forgery or falsification of the content or appearance of this document is unlawful and offenders may be prosecuted to the fullest extent of the law. Unless otherwise stated the results shown in this test report refer only to the sample(s) tested and such sample(s) are retained for 30 days only.

Attention: To check the authenticity of testing / inspection report & certificate, please contact us at telephone: (86-755) 8307 1443, or email: CN.Doccheck@sgs.com

SGS-CSTC Anji Branch Fire Technology Service

No. 301, Sunlight Road, 2 Block, Sunlight Industry Zone, Anji County, Zhejiang Province, China 313300 t (86-572) 5018825 f (86-572) 5018829 www.sgs.com.cn
中国·浙江·安吉县阳光工业园二区阳光大道301号 邮编:313300 t (86-572) 5018825 f (86-572) 5018829 e sgs.china@sgs.com

I. INTRODUCTION

This assessment report is for appraisal on “NETWORK CAMERA, Model No.: DS-2XM6522G0-ID”.

This assessment report presents an assessment of the ability of the “NETWORK CAMERA, Model No.: DS-2XM6522G0-ID” and whether it is acceptable applied in the scope which required the fire performance HL3, as the product used in railway vehicles, specified in EN 45545-2:2013+A1:2015.

II. REFERENCES

In this document the “NETWORK CAMERA, Model No.: DS-2XM6522G0-ID” applied by HANGZHOU HIKVISION DIGITAL TECHNOLOGY CO., LTD will be evaluated in respect of conformity to the generally recognized codes of practice. The assessment is based on the following standards;

1. EN 45545-1:2013 Railway applications - Fire protection on railway vehicles – Part 1: General;
2. EN 45545-2:2013+A1:2015 Railway applications—Fire protection on railway vehicles Part 2: Requirements for fire behaviour of materials and components;
3. 96/603/EC Commission decision of 4 October 1996, establishing the list of products to Class A “No contribution to fire” provided for in Decision 94/611/EC implementing Article 20 of Council Directive 89/106/EEC on construction products.
4. EN 60695-2-11:2014 Fire hazard testing — Part 2-11: Glowing/hot-wire based test methods - Glow-wire flammability test method for end-products (GWEPT), Glow wire temperature 850°C
5. IEC 60695-11-10:2013 Fire hazard testing –Part 11-10: Test flames – 50 W horizontal and vertical flame test methods

III. PRODUCT DETAILS OF ASSESSED**Part 1, General**

The details of the tested specimen given below have been prepared from information provided by the sponsor of the test. All values quoted are nominal, unless tolerances are given.

To be continued...



Unless otherwise agreed in writing, this document is issued by the Company subject to its General Conditions of Service printed overleaf, available on request or accessible at <http://www.sgs.com/en/Terms-and-Conditions.aspx> and, for electronic format documents, subject to Terms and Conditions for Electronic Documents at <http://www.sgs.com/en/Terms-and-Conditions/Terms-e-Documents.aspx>. Attention is drawn to the limitation of liability, indemnification and jurisdiction issues defined therein. Any holder of this document is advised that information contained hereon reflects the Company's findings at the time of its intervention only and within the limits of Client's instructions, if any. The Company's sole responsibility is to its Client and this document does not exonerate parties to a transaction from exercising all their rights and obligations under the transaction documents. This document cannot be reproduced except in full, without prior written approval of the Company. Any unauthorized alteration, forgery or falsification of the content or appearance of this document is unlawful and offenders may be prosecuted to the fullest extent of the law. Unless otherwise stated the results shown in this test report refer only to the sample(s) tested and such sample(s) are retained for 30 days only.

Attention: To check the authenticity of testing / inspection report & certificate, please contact us at telephone: (86-755) 8307 1443, or email: CN.Doccheck@sgs.com

No. 301, Sunlight Road, 2 Block, Sunlight Industry Zone, Anji County, Zhejiang Province, China 313300 t (86-572) 5018825 f (86-572) 5018829 www.sgs.com.cn
中国·浙江·安吉县阳光工业园二区阳光大道301号 邮编:313300 t (86-572) 5018825 f (86-572) 5018829 e sgs.china@sgs.com

General description	NETWORK CAMERA
Product Model	DS-2XM6522G0-ID
Weight	849g
Manufacturer	HANGZHOU HIKVISION DIGITAL TECHNOLOGY CO., LTD
Address:	NO.555, QIANMO ROAD, BINJIANG DISTRICT, HANGZHOU, 310052, CHINA
Factory:	HANGZHOU HIKVISION TECHNOLOGY CO., LTD, HANGZHOU HIKVISION ELECTRONICS CO., LTD, CHONGQING HIKVISION TECHNOLOGY CO., LTD
Address:	NO.700, DONGLIU ROAD, BINJIANG DISTRICT, HANGZHOU CITY, ZHEJIANG, 310052, CHINA NO.299, QIUSHI ROAD, TONGLU ECONOMIC DEVELOPMENT ZONE, TONGLU COUNTY, HANGZHOU, ZHEJIANG, 310052, CHINA NO.118, HAIKANG ROAD, AREA C, JIANQIAO INDUSTRIAL PARK, DADUKOU DISTRICT, CHONGQING, 401325, CHINA
Power	24V \equiv TBDA, TBDW
S/N	D74308979
End use	Railway Vehicle

The NETWORK CAMERA basically consists of: Metal enclosure, PCB, Rubber ring, Connection wire, Black PC, Plastic parts for lens, Silicone pad. The construction combines elements made of several plastics and metallic parts. The major mass of non-metal material is used for PCB, Rubber ring, Connection wire, Black PC, Plastic parts for lens and transparent hood for lens, Silicone pad and Base Shock Pad.

A list of materials is shown in the follow materials table provided by the manufacturer.



To be continued...



Unless otherwise agreed in writing, this document is issued by the Company subject to its General Conditions of Service printed overleaf, available on request or accessible at <http://www.sgs.com/en/Terms-and-Conditions.aspx> and, for electronic format documents, subject to Terms and Conditions for Electronic Documents at <http://www.sgs.com/en/Terms-and-Conditions/Terms-e-Documents.aspx>. Attention is drawn to the limitation of liability, indemnification and jurisdiction issues defined therein. Any holder of this document is advised that information contained hereon reflects the Company's findings at the time of its intervention only and within the limits of Client's instructions, if any. The Company's sole responsibility is to its Client and this document does not exonerate parties to a transaction from exercising all their rights and obligations under the transaction documents. This document cannot be reproduced except in full, without prior written approval of the Company. Any unauthorized alteration, forgery or falsification of the content or appearance of this document is unlawful and offenders may be prosecuted to the fullest extent of the law. Unless otherwise stated the results shown in this test report refer only to the sample(s) tested and such sample(s) are retained for 30 days only.

Attention: To check the authenticity of testing / inspection report & certificate, please contact us at telephone: (86-755) 8307 1443, or email: CN.Doccheck@sgs.com



Inside of the NETWORK CAMERA



Inside of the NETWORK CAMERA

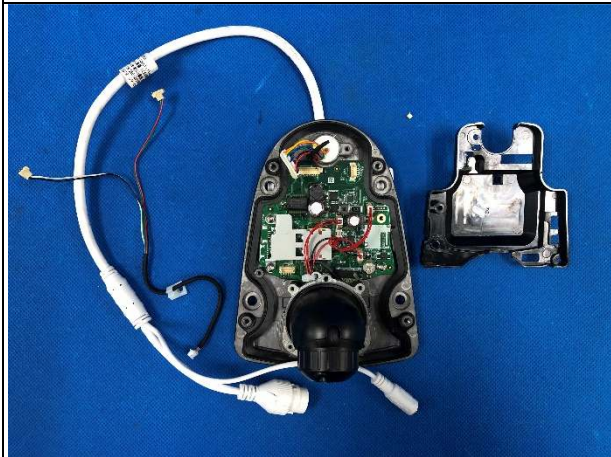

Inside of the NETWORK CAMERA



Inside of the NETWORK CAMERA

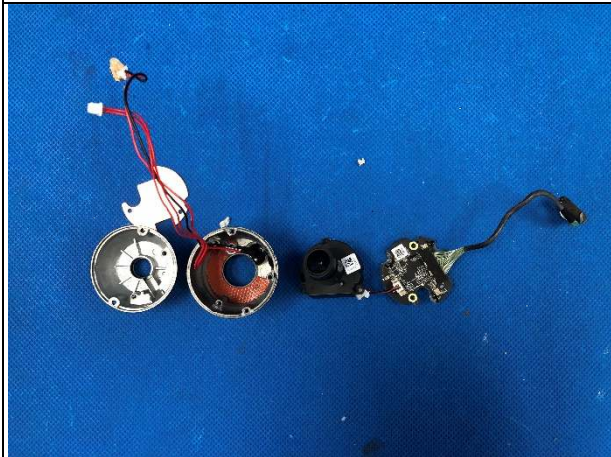

Inside of the NETWORK CAMERA



Inside of the NETWORK CAMERA

To be continued...



Unless otherwise agreed in writing, this document is issued by the Company subject to its General Conditions of Service printed overleaf, available on request or accessible at <http://www.sgs.com/en/Terms-and-Conditions.aspx> and, for electronic format documents, subject to Terms and Conditions for Electronic Documents at <http://www.sgs.com/en/Terms-and-Conditions/Terms-e-Documents.aspx>. Attention is drawn to the limitation of liability, indemnification and jurisdiction issues defined therein. Any holder of this document is advised that information contained hereon reflects the Company's findings at the time of its intervention only and within the limits of Client's instructions, if any. The Company's sole responsibility is to its Client and this document does not exonerate parties to a transaction from exercising all their rights and obligations under the transaction documents. This document cannot be reproduced except in full, without prior written approval of the Company. Any unauthorized alteration, forgery or falsification of the content or appearance of this document is unlawful and offenders may be prosecuted to the fullest extent of the law. Unless otherwise stated the results shown in this test report refer only to the sample(s) tested and such sample(s) are retained for 30 days only.

Attention: To check the authenticity of testing / inspection report & certificate, please contact us at telephone: (86-755) 8307 1443, or email: CN.Doccheck@sgs.com

No. 301, Sunlight Road, 2 Block, Sunlight Industry Zone, Anji County, Zhejiang Province, China 313300 t (86-572) 5018825 f (86-572) 5018829 www.sgs.com.cn
 中国·浙江·安吉县阳光工业园二区阳光大道301号 邮编:313300 t (86-572) 5018825 f (86-572) 5018829 e sgs.china@sgs.com

Part 2: Installation

The NETWORK CAMERA is designed for installation interior vehicles (e.g. in the passenger area, Ceiling). Based on the full metal enclosure except for the transparent hood for lens, the inner grouping will be separated from the adjacent components of the vehicle. Also the ceiling panel shall be comply the designed hazard level and it would be impossible to install some components around the camera with the 20mm range.

Part 3, Materials/components list

The evaluation is based on the combustible mass of materials. Therefore all combustible materials (plastic, PCB, etc) will be considered. Metallic materials are not combustible and therefore they will not be taken into account.

According to the sample details and the specification of EN 45545-2, the following materials are relevant for evaluation:

NETWORK CAMERA, Model No.: DS-2XM6522G0-ID						
No.	Description	Location	Mass, g	Requirement	Results	Remark
1	Enclosure-Metal	Outside	/	R22	A	96/603/EC, A1
2	PCB	Inside	31.6	R24/R25	R25 HL3	EN 45545-2, Clause 4.4, Table 2-Requirements of listed products, EL10 small electrotechnical products AJFS1903002593FF, date: APR 16. 2019
3	Rubber ring	Inside	5.7	No requirement	/	No requirements apply to products with a combustible mass of < 10 g not in touching contact with another unclassified product.
4	Connection Wire	Inside	5.6	No requirement	/	EN 45545-2, Clause 4.3, Total combustible Mass< 100g for grouped products (inside of camera), No requirement Total mass of inside of camera=23.5g
5	Black PC	Inside	12.3	R26	R26 HL3	EN 45545-2, Clause 4.4, Table 2-Requirements of listed products, EL10 small electrotechnical products UL File Number: QMFZ2.E45329 945(GG) V-0 (1.0mm-3.0mm)

To be continued...



Unless otherwise agreed in writing, this document is issued by the Company subject to its General Conditions of Service printed overleaf, available on request or accessible at <http://www.sgs.com/en/Terms-and-Conditions.aspx> and, for electronic format documents, subject to Terms and Conditions for Electronic Documents at <http://www.sgs.com/en/Terms-and-Conditions/Terms-e-Documents.aspx>. Attention is drawn to the limitation of liability, indemnification and jurisdiction issues defined therein. Any holder of this document is advised that information contained hereon reflects the Company's findings at the time of its intervention only and within the limits of Client's instructions, if any. The Company's sole responsibility is to its Client and this document does not exonerate parties to a transaction from exercising all their rights and obligations under the transaction documents. This document cannot be reproduced except in full, without prior written approval of the Company. Any unauthorized alteration, forgery or falsification of the content or appearance of this document is unlawful and offenders may be prosecuted to the fullest extent of the law. Unless otherwise stated the results shown in this test report refer only to the sample(s) tested and such sample(s) are retained for 30 days only.

Attention: To check the authenticity of testing / inspection report & certificate, please contact us at telephone: (86-755) 8307 1443, or email: CN.Doccheck@sgs.com

No. 301, Sunlight Road, 2 Block, Sunlight Industry Zone, Anji County, Zhejiang Province, China 313300 t (86-572) 5018825 f (86-572) 5018829 www.sgs.com.cn
 中国·浙江·安吉县阳光工业园二区阳光大道301号 邮编:313300 t (86-572) 5018825 f (86-572) 5018829 e sgs.china@sgs.com

NETWORK CAMERA, Model No.: DS-2XM6522G0-ID						
No.	Description	Location	Mass, g	Requirement	Results	Remark
6	Silicone pad	Inside	2.7	No requirement	/	EN 45545-2, Clause 4.3, Total combustible Mass < 100g for grouped products (inside of camera), No requirement Total mass of inside of camera=23.5g
7	Transparent hood for lens	Outside	6.8g	No requirement	/	No requirements apply to products with a combustible mass of < 10 g not in touching contact with another unclassified product.
8	Plastic parts for lens	Inside	7.4	No requirement	/	EN 45545-2, Clause 4.3, Total combustible Mass < 100g for grouped products (inside of camera), No requirement Total mass of inside of camera=23.5g
9	Lens PCB	Inside	4.2	No requirement	/	EN 45545-2, Clause 4.3, Total combustible Mass < 100g for grouped products (inside of camera), No requirement Total mass of inside of camera=23.5g
10	Lens wire	Inside	3.6	No requirement	/	EN 45545-2, Clause 4.3, Total combustible Mass < 100g for grouped products (inside of camera), No requirement Total mass of inside of camera=23.5g
11	Base Shock Pad	Outside	13.2	No requirement	/	EN 45545-2, Clause 4.3, Total combustible Mass < 100g for grouped products (Outside of camera), No requirement Total mass of outside of camera=54.3g
12	Connection Wire	Outside	41.1	No requirement	/	EN 45545-2, Clause 4.3, Total combustible Mass < 100g for grouped products (Outside of camera), No requirement Total mass of outside of camera=54.3g

To be continued...



Unless otherwise agreed in writing, this document is issued by the Company subject to its General Conditions of Service printed overleaf, available on request or accessible at <http://www.sgs.com/en/Terms-and-Conditions.aspx> and, for electronic format documents, subject to Terms and Conditions for Electronic Documents at <http://www.sgs.com/en/Terms-and-Conditions/Terms-e-Documents.aspx>. Attention is drawn to the limitation of liability, indemnification and jurisdiction issues defined therein. Any holder of this document is advised that information contained herein reflects the Company's findings at the time of its intervention only and within the limits of Client's instructions, if any. The Company's sole responsibility is to its Client and this document does not exonerate parties to a transaction from exercising all their rights and obligations under the transaction documents. This document cannot be reproduced except in full, without prior written approval of the Company. Any unauthorized alteration, forgery or falsification of the content or appearance of this document is unlawful and offenders may be prosecuted to the fullest extent of the law. Unless otherwise stated the results shown in this test report refer only to the sample(s) tested and such sample(s) are retained for 30 days only.

Attention: To check the authenticity of testing / inspection report & certificate, please contact us at telephone: (86-755) 8307 1443, or email: CN.Doccheck@sgs.com

No. 301, Sunlight Road, 2 Block, Sunlight Industry Zone, Anji County, Zhejiang Province, China 313300 t (86-572) 5018825 f (86-572) 5018829 www.sgs.com.cn
 中国·浙江·安吉县阳光工业园二区阳光大道301号 邮编:313300 t (86-572) 5018825 f (86-572) 5018829 e sgs.china@sgs.com

V. TEST REPORTS AND TEST RESULTS IN SUPPORT OF THIS ASSESSMENT

Name of the laboratory	Name of the sponsor	Test report ref.No.	Test methods	Test results
SGS-CSTC	HANGZHOU HIKVISION DIGITAL TECHNOLOGY CO., LTD	AJFS1903002593FF, date: APR 16. 2019	EN 60695-2-11	850°C Pass (ISO 17025 Accreditation)
UL	SABIC INNOVATIVE PLASTICS B V	UL File Number: QMFZ2.E45329 945(GG) V-0 (1.0mm-3.0mm)	IEC 60695-11-10	1.0mm-3.0mm V-0

VI. BASIS OF THIS ASSESSMENT

The basis for the evaluation of fire safety is the classification of vehicle types where the NETWORK CAMERA, Model No.: DS-2XM6522G0-ID will be installed.

Following classifications are taken as basis:

- EN 45545-2:2013+A1:2015 Railway applications—Fire protection on railway vehicles Part 2: Requirements for fire behaviour of materials and components, Hazard Level HL3

VII. ASSESSMENT ACCORDING TO EN 45545-2

Based on the requirements of EN 45545-2, the fire safety requirements for materials of electrical and electronic devices are defined in according to the installation location.

Considering the mass of combustible material of the NETWORK CAMERA, EN 45545-2 clause 4.2 n) “if listed products are used in an application below the mass and area thresholds given in 4.3, they may be treated as non-listed products” is applicable.

Therefore the requirements of clause 4.3 “Grouping rules” will be assessed.

To be continued...



Unless otherwise agreed in writing, this document is issued by the Company subject to its General Conditions of Service printed overleaf, available on request or accessible at <http://www.sgs.com/en/Terms-and-Conditions.aspx> and, for electronic format documents, subject to Terms and Conditions for Electronic Documents at <http://www.sgs.com/en/Terms-and-Conditions/Terms-e-Documents.aspx>. Attention is drawn to the limitation of liability, indemnification and jurisdiction issues defined therein. Any holder of this document is advised that information contained hereon reflects the Company's findings at the time of its intervention only and within the limits of Client's instructions, if any. The Company's sole responsibility is to its Client and this document does not exonerate parties to a transaction from exercising all their rights and obligations under the transaction documents. This document cannot be reproduced except in full, without prior written approval of the Company. Any unauthorized alteration, forgery or falsification of the content or appearance of this document is unlawful and offenders may be prosecuted to the fullest extent of the law. Unless otherwise stated the results shown in this test report refer only to the sample(s) tested and such sample(s) are retained for 30 days only.

Attention: To check the authenticity of testing / inspection report & certificate, please contact us at telephone: (86-755) 8307 1443, or email: CN.Doccheck@sgs.com

No. 301, Sunlight Road, 2 Block, Sunlight Industry Zone, Anji County, Zhejiang Province, China 313300 t (86-572) 5018825 f (86-572) 5018829 www.sgs.com.cn
 中国·浙江·安吉县阳光工业园二区阳光大道301号 邮编:313300 t (86-572) 5018825 f (86-572) 5018829 e sgs.china@sgs.com

Key applicable grouping rules:

- No requirements apply to products with a combustible mass of < 10 g not in touching contact with another unclassified product.
- If fully separated by a plate compliant with the fire integrity requirement of 5.3.6, then assign as different group.
- 4.3.2 Rule 1

If the total combustible mass of the grouped products is

- < 100 g for interior grouped products; or
- < 400 g for exterior grouped products;

no requirements apply to the products of this group.

- 4.3.3 Rule 2

If the total combustible mass of the grouped products is

- < 500 g for interior grouped products; or
- < 2000 g for exterior grouped products;

one combustible product of this group has to be tested according to R24.

Clause 4.2 General,

n) if listed products are used in an application below the mass and area thresholds given in 4.3, they may be treated as non-listed products.

Alternatively, the requirement set EL9 according to clause 4.4 Table 2 "Listed products" is applicable for PCB.

To be continued...



Unless otherwise agreed in writing, this document is issued by the Company subject to its General Conditions of Service printed overleaf, available on request or accessible at <http://www.sgs.com/en/Terms-and-Conditions.aspx> and, for electronic format documents, subject to Terms and Conditions for Electronic Documents at <http://www.sgs.com/en/Terms-and-Conditions/Terms-e-Documents.aspx>. Attention is drawn to the limitation of liability, indemnification and jurisdiction issues defined therein. Any holder of this document is advised that information contained hereon reflects the Company's findings at the time of its intervention only and within the limits of Client's instructions, if any. The Company's sole responsibility is to its Client and this document does not exonerate parties to a transaction from exercising all their rights and obligations under the transaction documents. This document cannot be reproduced except in full, without prior written approval of the Company. Any unauthorized alteration, forgery or falsification of the content or appearance of this document is unlawful and offenders may be prosecuted to the fullest extent of the law. Unless otherwise stated the results shown in this test report refer only to the sample(s) tested and such sample(s) are retained for 30 days only.

Attention: To check the authenticity of testing / inspection report & certificate, please contact us at telephone: (86-755) 8307 1443, or email: CN.Doccheck@sgs.com

ASSESSMENT:

PCB

As showed within the test report AJFS1903002593FF , it pass 850°C , complies with the requirements of HL3 defined in EN 45545-2:2013+A1:2015.

Rubber ring & Transparent hood for lens

No requirements apply to products with a combustible mass of < 10 g not in touching contact with another unclassified product.

Black PC

As showed within the UL Certificate QMFZ2.E45329, the results of the product 945(GG), which thickness 1-3mm, is **V-0**, complies with the requirements of HL3 defined in EN 45545-2:2013+A1:2015.

Connection Wire (Inside) + Silicone pad + Plastic parts for lens + Lens PCB + Lens wire

Total Mass of outside of camera=23.5g, according to the EN 45545-2:2013+A1:2015 4.3.2 Rule 1

“If the total combustible mass of the grouped products (Inside grouped) is

- < 100 g for interior grouped products; or
- < 400 g for exterior grouped products;
- no requirements apply to the products of this group.”

So, no requirement.

Connection Wire (outside) + Base Shock Pad

Total Mass of outside of camera=54.3g, according to the EN 45545-2:2013+A1:2015 4.3.2 Rule 1

“If the total combustible mass of the grouped products (Outside grouped) is

- < 100 g for interior grouped products; or
- < 400 g for exterior grouped products;
- no requirements apply to the products of this group.”

So, no requirement.

To be continued...



Unless otherwise agreed in writing, this document is issued by the Company subject to its General Conditions of Service printed overleaf, available on request or accessible at <http://www.sgs.com/en/Terms-and-Conditions.aspx> and, for electronic format documents, subject to Terms and Conditions for Electronic Documents at <http://www.sgs.com/en/Terms-and-Conditions/Terms-e-Documents.aspx>. Attention is drawn to the limitation of liability, indemnification and jurisdiction issues defined therein. Any holder of this document is advised that information contained hereon reflects the Company's findings at the time of its intervention only and within the limits of Client's instructions, if any. The Company's sole responsibility is to its Client and this document does not exonerate parties to a transaction from exercising all their rights and obligations under the transaction documents. This document cannot be reproduced except in full, without prior written approval of the Company. Any unauthorized alteration, forgery or falsification of the content or appearance of this document is unlawful and offenders may be prosecuted to the fullest extent of the law. Unless otherwise stated the results shown in this test report refer only to the sample(s) tested and such sample(s) are retained for 30 days only.

Attention: To check the authenticity of testing / inspection report & certificate, please contact us at telephone: (86-755) 8307 1443, or email: CN.Doccheck@sgs.com

No. 301, Sunlight Road, 2 Block, Sunlight Industry Zone, Anji County, Zhejiang Province, China 313300 t (86-572) 5018825 f (86-572) 5018829 www.sgs.com.cn
中国·浙江·安吉县阳光工业园二区阳光大道301号 邮编:313300 t (86-572) 5018825 f (86-572) 5018829 e sgs.china@sgs.com

Assessment of the ignite risks

General speaking, no potential ignition source around the ceiling installed NETWORK CAMERA. An ignition inside the NETWORK CAMERA via a technical defect cannot be fundamentally excluded, but is extremely unlikely and the inside materials also complies with the criteria of fire performance, there are no ignite risks.

Assessment of the risks of a further fire development:

Because of its tight design and metal enclosure, the ignition and fire occurring inside and outside the device are limited. Also the quantity of the combustion materials is very limited. A fire development and spreading from the NETWORK CAMERA are thus also not conceivable.

Based on the test report and evaluation, it shows that the tested product does not have recognizable ignition and fire risks and evaluated as conform to the requirement of EN 45545-2, Clause 4.1 essential fire safety objectives.

VIII. CONCLUSION

The fire protection documents and limitation are evaluated based on the standards EN 45545-1:2013 and EN 45545-2:2013+A1:2015.

The evaluation of all the presented descriptions, test report and documents show that the construction and material selection of the NETWORK CAMERA comply with the requirements HL1 to HL3 of EN 45545-1:2013 and EN 45545-2:2013+A1:2015.

The evaluation is based on the verified demonstration documents.

IX. LIMITATION

As for fire safety of evaluated product, there are no restrictions and conditions. They can be used in all the operation and construction class in the rail vehicles without restrictions.

As for fire safety of evaluated product, based on the grouping ruler of EN 45545-2 clause 4.3, there should be no any unclassified product around the camera within horizontal distance 20 mm and the vertical distance 200 mm, except from the contact unclassified product with mass less 10g.

If more accessories were used together with the NETWORK CAMERA, should be re-evaluated based on the requirements of EN 45545-2 and installing conditions.

To be continued...



Unless otherwise agreed in writing, this document is issued by the Company subject to its General Conditions of Service printed overleaf, available on request or accessible at <http://www.sgs.com/en/Terms-and-Conditions.aspx> and, for electronic format documents, subject to Terms and Conditions for Electronic Documents at <http://www.sgs.com/en/Terms-and-Conditions/Terms-e-Documents.aspx>. Attention is drawn to the limitation of liability, indemnification and jurisdiction issues defined therein. Any holder of this document is advised that information contained hereon reflects the Company's findings at the time of its intervention only and within the limits of Client's instructions, if any. The Company's sole responsibility is to its Client and this document does not exonerate parties to a transaction from exercising all their rights and obligations under the transaction documents. This document cannot be reproduced except in full, without prior written approval of the Company. Any unauthorized alteration, forgery or falsification of the content or appearance of this document is unlawful and offenders may be prosecuted to the fullest extent of the law. Unless otherwise stated the results shown in this test report refer only to the sample(s) tested and such sample(s) are retained for 30 days only.

Attention: To check the authenticity of testing / inspection report & certificate, please contact us at telephone: (86-755) 8307 1443, or email: CN.Doccheck@sgs.com

No. 301, Sunlight Road, 2 Block, Sunlight Industry Zone, Anji County, Zhejiang Province, China 313300 t (86-572) 5018825 f (86-572) 5018829 www.sgs.com.cn
 中国·浙江·安吉县阳光工业园二区阳光大道301号 邮编: 313300 t (86-572) 5018825 f (86-572) 5018829 e sgs.china@sgs.com

STATEMENTS:

The assess results relate only to the product in the form in which were assessed.

The purpose of the report is to provide a general overview of the evidence currently available and it should be read in conjunction with the specific reports detailed for each product where additional information is required.

As the statement by sponsor, the NETWORK CAMERA with Model No.: DS-2XM6522G0-ID, is same as the NETWORK CAMERA with Model No.: DS-2XM6522WD-IM, except from the outside connection wire.

All documents and assessment are copied from the report No. AJFS1904003330FF (Date, May 16, 2019, NETWORK CAMERA, Model No.: DS-2XM6522WD-IM).

Additional Information (Provide by sponsor)

DS-2XM6512G0-ID,DS-2XM6512G0-IDUHK,DS-2XM6512G0-IDCKV,DS-2XM6512G0-IDUVS,DS-2XM6512G0-IDKVO,DS-2XM6512G0-IDHUN,DS-2XM6512G0-IDM,DS-2XM6512G0-IDMUHK,DS-2XM6512G0-IDMCKV,DS-2XM6512G0-IDMUVS,DS-2XM6512G0-IDMKVO,DS-2XM6512G0-IDMHUN,DS-2XM6522G0-IDUHK,DS-2XM6522G0-IDCKV,DS-2XM6522G0-IDUVS,DS-2XM6522G0-IDKVO,DS-2XM6522G0-IDHUN,DS-2XM6522G0-IDM,DS-2XM6522G0-IDMUHK,DS-2XM6522G0-IDMCKV,DS-2XM6522G0-IDMUVS,DS-2XM6522G0-IDMKVO,DS-2XM6522G0-IDMHUN,DS-2XM6522G0-I/ND,DS-2XM6512G0-I/ND,DS-2XM6512G0-I/NDUHK,DS-2XM6512G0-I/NDCKV,DS-2XM6512G0-I/NDUVS,DS-2XM6512G0-I/NDKVO,DS-2XM6512G0-I/NDHUN,DS-2XM6512G0-IM/ND,DS-2XM6512G0-IM/NDUHK,DS-2XM6512G0-IM/NDCKV,DS-2XM6512G0-IM/NDUVS,DS-2XM6512G0-IM/NDKVO,DS-2XM6512G0-IM/NDHUN,DS-2XM6522G0-I/NDUHK,DS-2XM6522G0-I/NDCKV,DS-2XM6522G0-I/NDUVS,DS-2XM6522G0-I/NDKVO,DS-2XM6522G0-I/NDHUN,DS-2XM6522G0-IM/ND,DS-2XM6522G0-IM/NDUHK,DS-2XM6522G0-IM/NDCKV,DS-2XM6522G0-IM/NDUVS,DS-2XM6522G0-IM/NDKVO,DS-2XM6522G0-IM/NDHUN,DS-2XM6512WD-ID,DS-2XM6512WD-IDUHK,DS-2XM6512WD-IDCKV,DS-2XM6512WD-IDUVS,DS-2XM6512WD-IDKVO,DS-2XM6512WD-IDHUN,DS-2XM6512WD-IDM,DS-2XM6512WD-IDMUHK,DS-2XM6512WD-IDMCKV,DS-2XM6512WD-IDMUVS,DS-2XM6512WD-IDMKVO,DS-2XM6512WD-IDMHUN,DS-2XM6522WD-ID,DS-2XM6522WD-IDUHK,DS-2XM6522WD-IDCKV,DS-2XM6522WD-IDUVS,DS-2XM6522WD-IDKVO,DS-2XM6522WD-IDHUN,DS-2XM6522WD-IDM,DS-2XM6522WD-IDMUHK,DS-2XM6522WD-IDMCKV,DS-2XM6522WD-IDMUVS,DS-2XM6522WD-IDMKVO,DS-2XM6522WD-IDMHUN,DS-2XM6512WD-IM,DS-2XM6512WD-IMUHK,DS-2XM6512WD-IMCKV,DS-2XM6512WD-IMUVS,DS-2XM6512WD-IMKVO,DS-2XM6512WD-IMHUN,

To be continued...



Unless otherwise agreed in writing, this document is issued by the Company subject to its General Conditions of Service printed overleaf, available on request or accessible at <http://www.sgs.com/en/Terms-and-Conditions.aspx> and, for electronic format documents, subject to Terms and Conditions for Electronic Documents at <http://www.sgs.com/en/Terms-and-Conditions/Terms-e-Documents.aspx>. Attention is drawn to the limitation of liability, indemnification and jurisdiction issues defined therein. Any holder of this document is advised that information contained hereon reflects the Company's findings at the time of its intervention only and within the limits of Client's instructions, if any. The Company's sole responsibility is to its Client and this document does not exonerate parties to a transaction from exercising all their rights and obligations under the transaction documents. This document cannot be reproduced except in full, without prior written approval of the Company. Any unauthorized alteration, forgery or falsification of the content or appearance of this document is unlawful and offenders may be prosecuted to the fullest extent of the law. Unless otherwise stated the results shown in this test report refer only to the sample(s) tested and such sample(s) are retained for 30 days only.

Attention: To check the authenticity of testing / inspection report & certificate, please contact us at telephone: (86-755) 8307 1443, or email: CN.Doccheck@sgs.com

No. 301, Sunlight Road, 2 Block, Sunlight Industry Zone, Anji County, Zhejiang Province, China 313300 t (86-572) 5018825 f (86-572) 5018829 www.sgs.com.cn
中国·浙江·安吉县阳光工业园二区阳光大道301号 邮编:313300 t (86-572) 5018825 f (86-572) 5018829 e sgs.china@sgs.com

DS-2XM6522WD-IM,DS-2XM6522WD-IMUHK,DS-2XM6522WD-IMCKV,DS-2XM6522WD-IMUVS,DS-2XM6522WD-IMKVO,DS-2XM6522WD-IMHUN, DS-2XM6512WD-I/ND,DS-2XM6512WD-I/NDUHK,DS-2XM6512WD-I/NDCKV,DS-2XM6512WD-I/NDUVS,DS-2XM6512WD-I/NDKVO,DS-2XM6512WD-I/NDHUN,DS-2XM6512WD-IM/ND,DS-2XM6512WD-IM/NDUHK,DS-2XM6512WD-IM/NDCKV,DS-2XM6512WD-IM/NDUVS,DS-2XM6512WD-IM/NDKVO,DS-2XM6512WD-IM/NDHUN,DS-2XM6522WD-I/ND,DS-2XM6522WD-I/NDUHK,DS-2XM6522WD-I/NDCKV,DS-2XM6522WD-I/NDUVS,DS-2XM6522WD-I/NDKVO,DS-2XM6522WD-I/NDHUN,DS-2XM6522WD-IM/ND,DS-2XM6522WD-IM/NDUHK,DS-2XM6522WD-IM/NDCKV,DS-2XM6522WD-IM/NDUVS,DS-2XM6522WD-IM/NDKVO,DS-2XM6522WD-IM/NDHUN,DS-2XM6512WD-IM/ND,DS-2XM6512WD-IM/NDUHK,DS-2XM6512WD-IM/NDCKV,DS-2XM6512WD-IM/NDUVS,DS-2XM6512WD-IM/NDKVO,DS-2XM6512WD-IM/NDHUN,DS-2XM6522WD-IM/ND,DS-2XM6522WD-IM/NDUHK,DS-2XM6522WD-IM/NDCKV,DS-2XM6522WD-IM/NDUVS,DS-2XM6522WD-IM/NDKVO,DS-2XM6522WD-IM/NDHUN.

As the statement by sponsor, above model are identical with the product with model No. DS-2XM6522G0-ID, except from the electric circuit of the PCB.

Based on the specification of EN 45545-2, the difference of the electric circuit of the PCB are not relevant to the fire behavior of the product, so the conclusion of this document is also applicable for the products with above additional model No.

To be continued...



Unless otherwise agreed in writing, this document is issued by the Company subject to its General Conditions of Service printed overleaf, available on request or accessible at <http://www.sgs.com/en/Terms-and-Conditions.aspx> and, for electronic format documents, subject to Terms and Conditions for Electronic Documents at <http://www.sgs.com/en/Terms-and-Conditions/Terms-e-Documents.aspx>. Attention is drawn to the limitation of liability, indemnification and jurisdiction issues defined therein. Any holder of this document is advised that information contained hereon reflects the Company's findings at the time of its intervention only and within the limits of Client's instructions, if any. The Company's sole responsibility is to its Client and this document does not exonerate parties to a transaction from exercising all their rights and obligations under the transaction documents. This document cannot be reproduced except in full, without prior written approval of the Company. Any unauthorized alteration, forgery or falsification of the content or appearance of this document is unlawful and offenders may be prosecuted to the fullest extent of the law. Unless otherwise stated the results shown in this test report refer only to the sample(s) tested and such sample(s) are retained for 30 days only.

Attention: To check the authenticity of testing / inspection report & certificate, please contact us at telephone: (86-755) 8307 1443, or email: CN.Doccheck@sgs.com

Appendix 1: Photo



To be continued...

Appendix 2, Module Structure

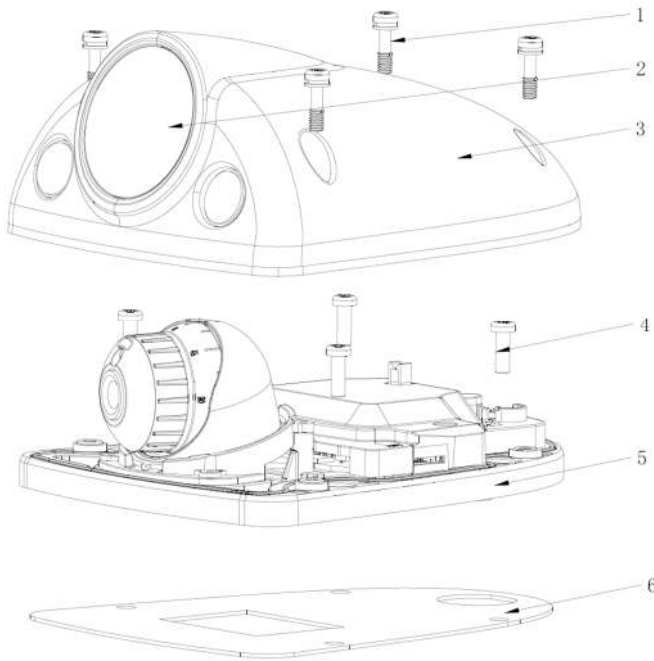

No.	Name	Material	Quantity
1	M4 Screw	SUS304	4
2	Cover of camera	PC	1
3	Cover assembly	ADC12(铝材)	1
4	M4 Screw	SUS304	4
5	Main Body	ADC12	1
6	Base Shock Pad	Silica gel	1

SGS authenticate the photo on original report only

End of Report



Unless otherwise agreed in writing, this document is issued by the Company subject to its General Conditions of Service printed overleaf, available on request or accessible at <http://www.sgs.com/en/Terms-and-Conditions.aspx> and, for electronic format documents, subject to Terms and Conditions for Electronic Documents at <http://www.sgs.com/en/Terms-and-Conditions/Terms-e-Documents.aspx>. Attention is drawn to the limitation of liability, indemnification and jurisdiction issues defined therein. Any holder of this document is advised that information contained hereon reflects the Company's findings at the time of its intervention only and within the limits of Client's instructions, if any. The Company's sole responsibility is to its Client and this document does not exonerate parties to a transaction from exercising all their rights and obligations under the transaction documents. This document cannot be reproduced except in full, without prior written approval of the Company. Any unauthorized alteration, forgery or falsification of the content or appearance of this document is unlawful and offenders may be prosecuted to the fullest extent of the law. Unless otherwise stated the results shown in this test report refer only to the sample(s) tested and such sample(s) are retained for 30 days only.

Attention: To check the authenticity of testing / inspection report & certificate, please contact us at telephone: (86-755) 8307 1443, or email: CN.Doccheck@sgs.com

SGS-CSTC Technical Services Co., Ltd.
Anji Branch Fire Technology Service

No. 301, Sunlight Road, 2 Block, Sunlight Industry Zone, Anji County, Zhejiang Province, China 313300 t (86-572) 5018825 f (86-572) 5018829 www.sgs.com.cn
中国·浙江·安吉县阳光工业园二区阳光大道301号 邮编:313300 t (86-572) 5018825 f (86-572) 5018829 e sgs.china@sgs.com