

## COMMUNICATION

issued by: **Road traffic safety directorate**

concerning<sup>1</sup>: **APPROVAL GRANTED**  
~~APPROVAL EXTENDED~~  
~~APPROVAL REFUSED~~  
~~APPROVAL WITHDRAWN~~  
~~PRODUCTION DEFINITELY DISCONTINUED~~

of a component type pursuant to Regulation No. 118

Approval No. **E32\*118RII03/01\*0056\*00**Extension No. **00**Reason for extension: **Not applicable**

## Section I

## General

- 1.1. Make (trade name of manufacturer): **HIKVISION**
- 1.2. Type: **DS-2XM6DX2G0-I/ND**
- 1.3. Means of identification of type, if marked on the device<sup>b</sup>: **Not applicable**
- 1.3.1. Location of that marking: **Not applicable**
- 1.4. Name and address of manufacturer: **Hangzhou Hikvision Digital Technology Co., Ltd.  
No.555 Qianmo Road, Binjiang District,  
Hangzhou City, Zhejiang Province,  
P.R. China**
- 1.5. Location of the approval mark: **Sticker on the camera**
- 1.6. Address(es) of assembly plant(s): **Hangzhou Hikvision Digital Technology Co., Ltd.  
No.555 Qianmo Road, Binjiang District,  
Hangzhou City, Zhejiang Province,  
P.R. China**

<sup>1</sup> Strike out what does not apply (there are cases where nothing needs to be deleted, when more than one entry is applicable)

<sup>b</sup> If the means of identification of type contains characters not relevant to describe the vehicle, component or separate technical unit types covered in this information document, such characters shall be represented in the documentation by the symbol “?” (e.g. ABC??123??).

## Section II

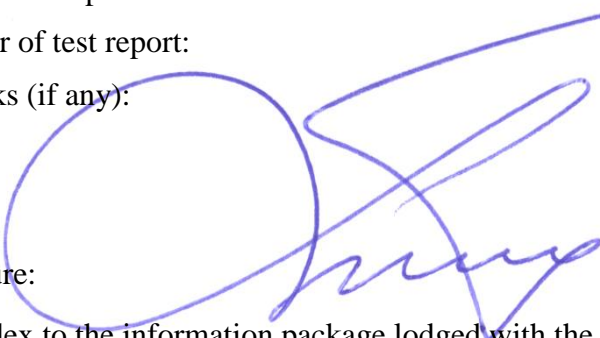
1. Additional information (where applicable): **See Appendix 1**
2. Technical Service responsible for carrying out the tests: **TŪV Rheinland-KTI Ltd.**
3. Date of test report: **02.01.2020**
4. Number of test report: **87-R118-203/20-00**
5. Remarks (if any): **Not applicable**
6. Place: **6, S.Eizensteina St., Riga  
LV-1079, Latvia**
7. Date: **10.01.2020**
8. Signature:  **Jānis Liepiņš**
9. The index to the information package lodged with the Type Approval Authority, which may be obtained on request, is attached.



Attachments: Information package. **DS-2XM6DX2G0-I/ND-R118-00**  
Test report. **87-R118-203/20-00, 02.01.2020**

## Appendix 1

### Appendix to type approval communication form No. E32\*118R1103/01\*0056\*00 concerning the type approval of a component type pursuant to Regulation No. 118

1. Additional information.
  - 1.1. Interior materials
    - 1.1.1. The direction which the component may be installed: **Not applicable**
    - 1.1.2. Fulfils the requirements in paragraph 6.2.2.: ~~yes~~/**not applicable**<sup>1</sup>
    - 1.1.3. Compliance has been checked for components approved as completed devices: ~~yes~~/**no**<sup>1</sup>
    - 1.1.4. Any restrictions of use and installation requirements: **Not applicable**
  - 1.2. Insulation materials
    - 1.2.1. The direction which the component may be installed: **Not applicable**
    - 1.2.2. Compliance has been checked for components approved as complete devices: ~~yes~~/**no**<sup>1</sup>
    - 1.2.3. Any restrictions of use and installation requirements: **Not applicable**
  - 1.3. Electric cables
    - 1.3.1. Any restrictions of use and installation requirements: **No**
2. Remarks: **Camera with electrical cable**



---

<sup>1</sup> Strike out what does not apply.

**uniform provisions concerning the  
burning behaviour and/or the capability to repel fuel or lubricant of materials used in the con-  
struction of certain categories of motor vehicles**

**Part II**

**UN-Regulation No. 118  
Amend. 03, Suppl. 1**



# INFORMATION DOCUMENT

Doc. No.: DS-2XM6DX2G0-I/ND-R118-00

Issue Date: November 27, 2019

**HIKVISION**

Manufacturer : Hangzhou Hikvision Digital Technology Co., Ltd.

Type : DS-2XM6DX2G0-I/ND

## AMENDMENT

Version	Approval No.	Modification / Correction	Date
00	---	First application	November 27, 2019

## CONTENT

1	General.....	3
2	Interior materials.....	3
3	Insulation materials.....	3
4	Electric Cables.....	3
	Annex 1 Drawing of Cable.....	4
	Annex 2 Specification of cable.....	6
	Annex 3 Drawing of product.....	7
	Annex 4 Assembly of product and material list.....	11



## INFORMATION DOCUMENT

Doc. No.: DS-2XM6DX2G0-I/ND-R118-00

Issue Date: November 27, 2019

**HIKVISION**

Manufacturer : Hangzhou Hikvision Digital Technology Co., Ltd.

Type : DS-2XM6DX2G0-I/ND

---

- 1 General
- 1.1 Make (trade name of manufacturer) : HIKVISION
- 1.2 Type and general commercial descriptions : Type: DS-2XM6DX2G0-I/ND  
Commercial descriptions:  
DS-2XM6D82G0-I/ND, DS-2XM6D52G0-I/ND,  
DS-2XM6122G0-I/ND, DS-2XM6112G0-I/ND,  
DS-2XM6222G0-I/ND, DS-2XM6212G0-I/ND,  
DS-2XM6522G0-I/ND, DS-2XM6512G0-I/ND
- 1.3 Name and address of manufacturer : Hangzhou Hikvision Digital Technology Co., Ltd.  
No.555 Qianmo Road, Binjiang District,  
Hangzhou City, Zhejiang Province, China
- 1.4 In the case of components and separate technical units, location and method of affixing of the UN approval mark: : Stick on the camera
- 1.5 Name(s) and address(es) of assembly plant(s) : Same as 1.3
2. Interior materials : Not applicable
3. Insulation Materials : Not applicable
4. Electric Cables
- 4.1. Material(s) used for : Camera
- 4.2. Base material(s)/designation : See Annex 1 and Annex 2
- 4.3. Composite/single material, number of layers : See Annex 2
- 4.4. Type of coating : Not applicable
- 4.5. Maximum/minimum thickness : See Annex 2
- 4.6. Type approval number, if available : Not applicable



HIKVISION

Manufacturer : Hangzhou Hikvision Digital Technology Co., Ltd.

Type : DS-2XM6DX2G0-I/ND

Annex 1 Drawing of Cable

UL20789 (28AWG\*2P+MY+Hot-melt AL.Mylar)+28AWG\*2P+AEB

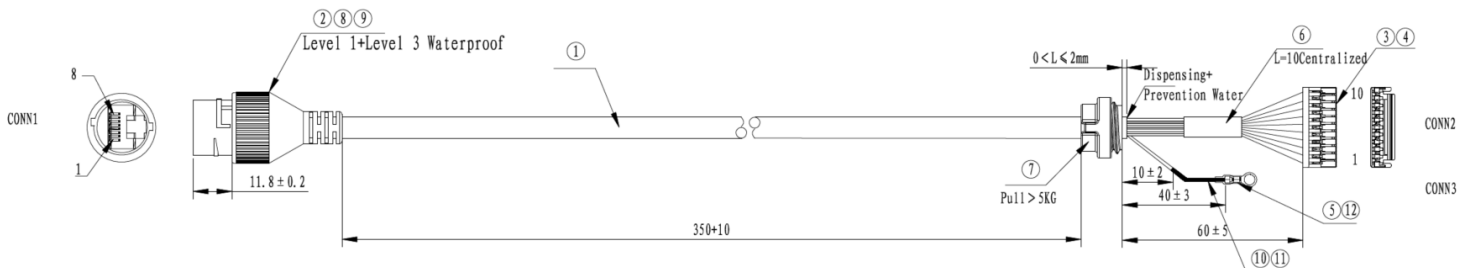
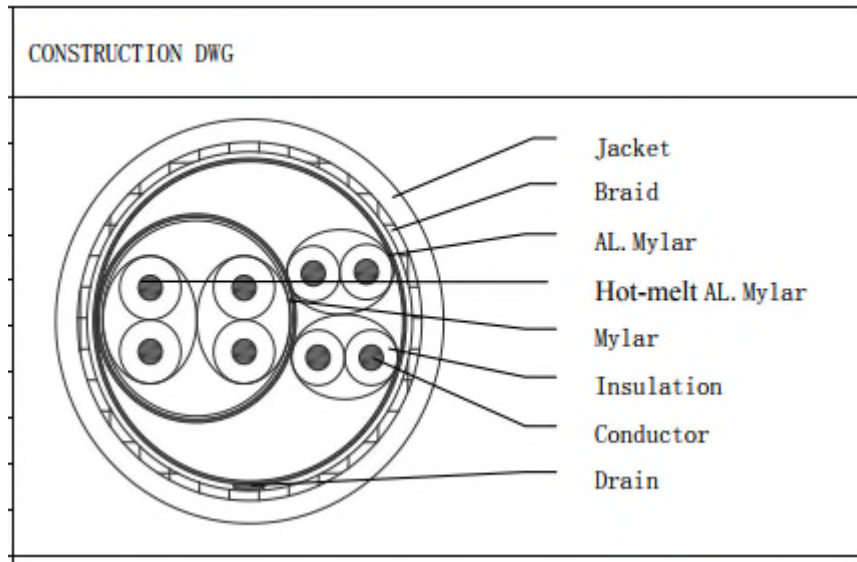

12	Heat shrink sleeve black Ø2.5mm black printing	/	KG
11	Heat shrink sleeve black OD1.0 black	1	PC
10	UL1007, 24AWG electronic line OD1.4 black	1	PC
9	PE transparent inner mold material PEMA1850A	1	PC
8	60P (81A) New Haekang RAL9003 -30-60°C,	1	PC
7	35P New Haekang white RAL9003 -40-105°C	1	PC
6	OD5.0mm White shrinkable pipe halogen-free flame retardant non-printing Volt	8	PCS
5	OT terminal copper tin plating with M2 stud fits 22-26AWG KST:DRNB2-0.5	1	PC
4	HSG1.25 Spacing GH-10P White PN, A1259001019P60 (Conley).	1	PC
3	GH 1.25 Spacing bronze tinned terminal PN. B12590T2AA110 (Conley).	1	PC
2	Roud R145 gold plated lu white no short circuit	1	PC
1	UL20789 (28AWG*2P+MY+ Hot-melt AL.Mylar) +28AWG*2P+AEB OD: 6.2 CW1 half matt	1	PC
	DESCRIPTION	Q' TY	UNIT

HIKVISION

Manufacturer : Hangzhou Hikvision Digital Technology Co., Ltd.

Type : DS-2XM6DX2G0-I/ND

1. Front view of plug

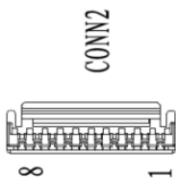

1. 接线表

CONN1	CONN2	颜色	Wire specification
1	1	Orange	7/0.127
2	2	Yellow	7/0.127
3	3	Green	7/0.127
6	4	Blue	7/0.127
5	5	Gray	7/0.127
4	6	Purple	7/0.127
7	7	Brown	7/0.127
8	8	White	7/0.127

3. Wire cross section

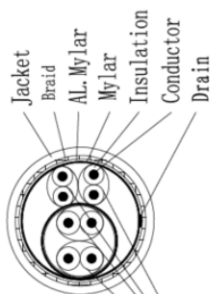

28# 7/0.127  
 Orange\*Yellow  
 Green\*Blue  
 Purple\*Gray  
 Brown\*White

4. Electrical test conditions:  
 A. DC > 300V  
 B. Insulation impedance: > 20MΩ  
 C. Conduction impedance: < 1.0Ω

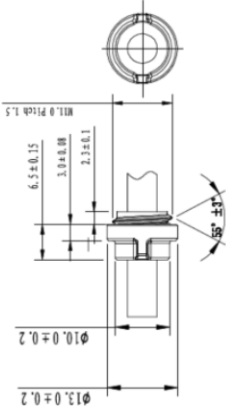

5. Injection mold comparison table:

NAME	TYPE	MOLD NO.
RJ45F	TYPE	41018012
	TYPE	410218004
SR	TYPE	410316257



**HIKVISION**

Manufacturer : Hangzhou Hikvision Digital Technology Co., Ltd.

Type : DS-2XM6DX2G0-I/ND

**Annex 2 Specification of cable**

UL20789 (28AWG\*2P+MY+Hot-melt AL.Mylar)+28AWG\*2P+AEB

P/N	200008397	SPECIFICATION	UL20789 (28AWG*2P+MY+ Hot-melt AL.Mylar)+28AWG*2P+AEB OD:6.2 CW1 half matt	
ITEM		SPECIFICATION		
Conductor	AWG	28AWG	28AWG	28AWG
	MATERIAL	Tinned Copper	Tinned Copper	Tinned Copper
	COND. SIZE	7/0.127±0.008mm	7/0.127±0.008mm	7/0.127±0.008mm
Insulation	MIN. AVG. THICK	0.27mm (REF)	0.22mm (REF)	0.22mm (REF)
	MATERIAL	SR-PVC 105℃	SR-PVC 105℃	SR-PVC 105℃
	O. D	0.98±0.05mm	0.85±0.05mm	0.85±0.05mm
	NO.	2P	2P	2P
LAY	LAY	/	/	/
Mylar	COVERAGE	100%	/	/
AL. Mylar	COVERAGE	100%	/	/
	OVERLAP	25% (REF)	/	/
AL. Mylar	COVERAGE	100%		
	OVERLAP	25% (REF)		
Drain	AWG	24AWG		
	MATERIAL	Bare copper		
	SIZE	1/0.50±0.008mm		
Braid	MATERIAL	Tinned Copper		
	COVERAGE	>95%		
Jacket	MIN. AVG. THICK	0.43mm (REF)		
	MATERIAL	70P PVC -40℃~105℃ VW-1		
	COLOR	CW1 half matt		
	O. D	6.2 + 0/-0.20mm		



HIKVISION

Manufacturer : Hangzhou Hikvision Digital Technology Co., Ltd.

Type : DS-2XM6DX2G0-I/ND

Annex 3 Drawing of product

XM6D:

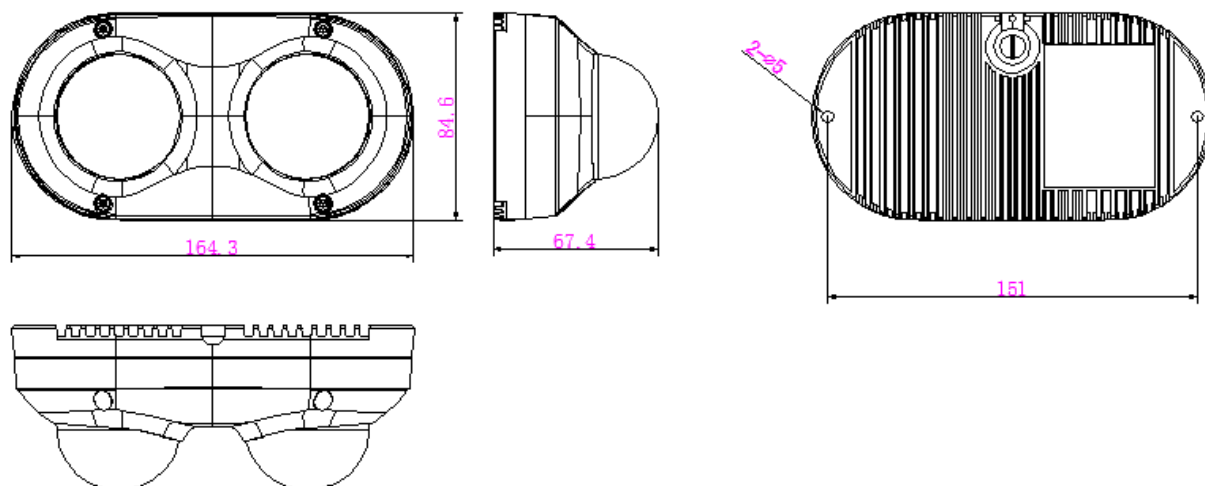

XM61:

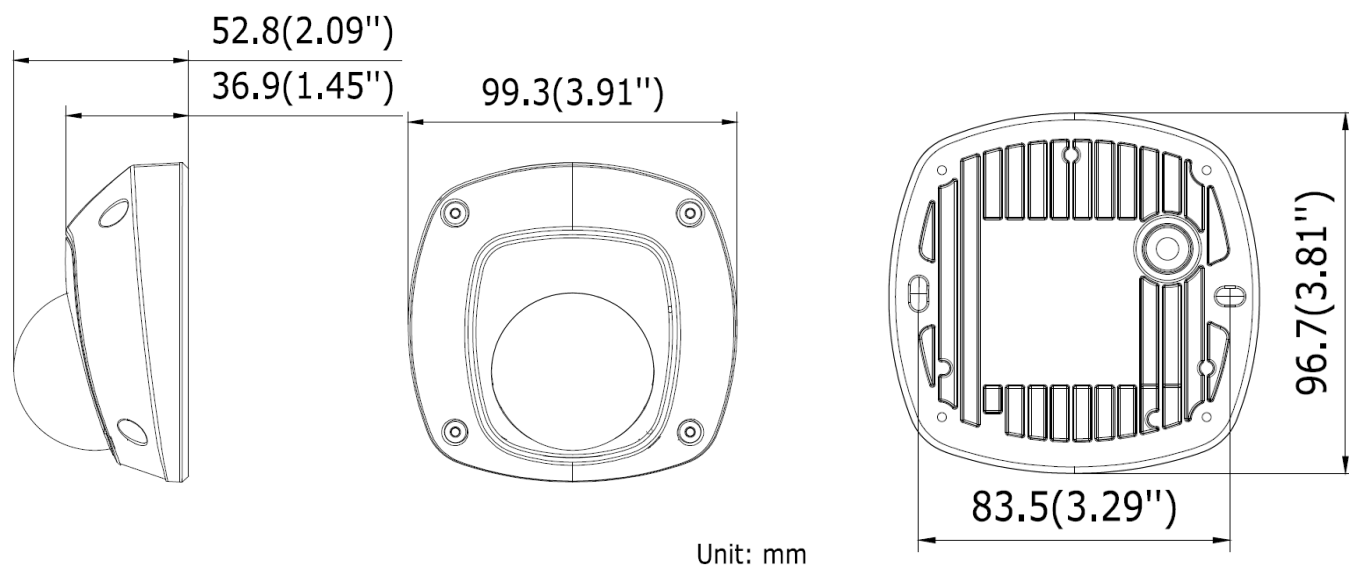

HIKVISION

Manufacturer : Hangzhou Hikvision Digital Technology Co., Ltd.

Type : DS-2XM6DX2G0-I/ND

XM62:

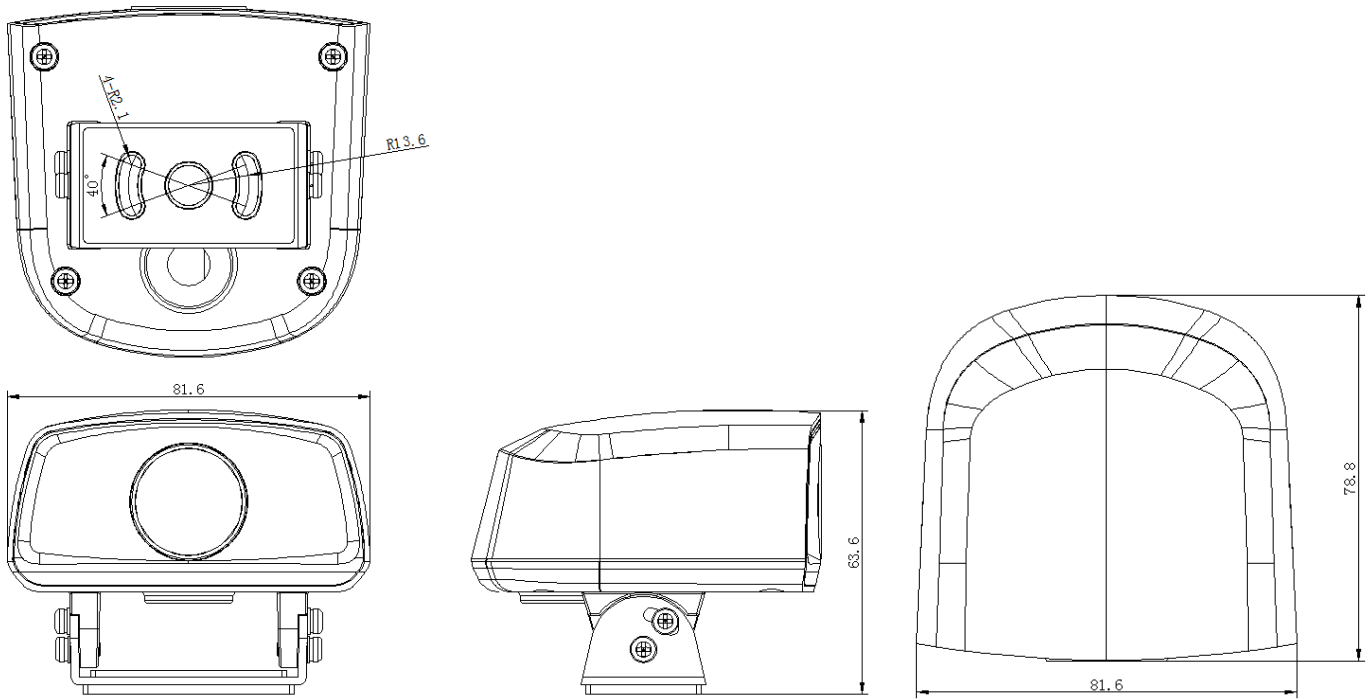

XM65:

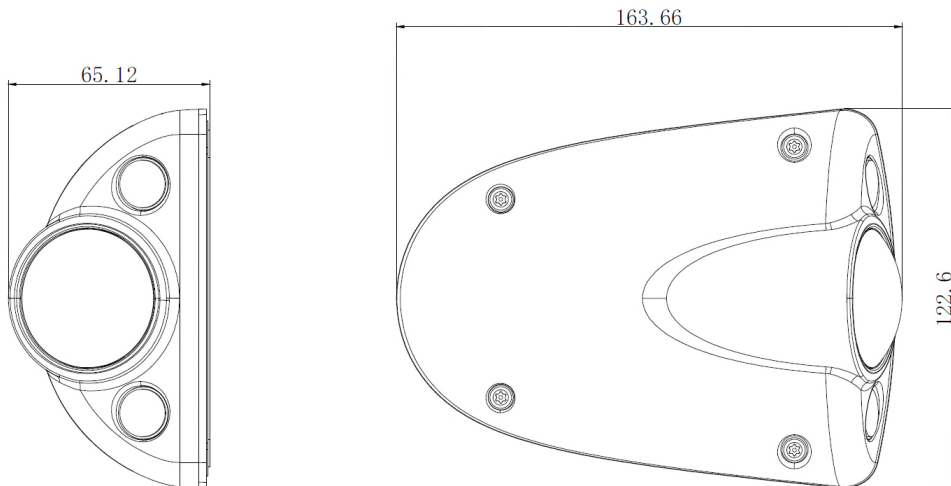

Unit: mm



HIKVISION

Manufacturer : Hangzhou Hikvision Digital Technology Co., Ltd.

Type : DS-2XM6DX2G0-I/ND

**HIKVISION**

**NETWORK CAMERA**

Model: DS-2XM6DX2G0-I/ND

SN: SV:



CAN ICES-3(B)/NMB-3(B)

I/P: PoE(802.3af,36-57V)=0.28-0.18A,10W

MAC Address: 58:03:FB:2F:FF:FE

Manufacturer: Hangzhou Hikvision Digital Technology Co.,Ltd.

Address: No.555 Qianmo Road, Binjiang District, Hangzhou 310052, China



Made in China

### E mark Convention



$a \geq 8 \text{ mm}$



**HIKVISION**

Manufacturer : Hangzhou Hikvision Digital Technology Co., Ltd.

Type : DS-2XM6DX2G0-I/ND

Location of approval mark: Stick on the camera

XM6D:



Position of marking

XM61:



Position of marking

XM62:



Position of marking

XM65:



Position of marking





**HIKVISION**

Manufacturer : Hangzhou Hikvision Digital Technology Co., Ltd.

Type : DS-2XM6DX2G0-I/ND

**Annex 4 Assembly of product and material list**

XM6D:

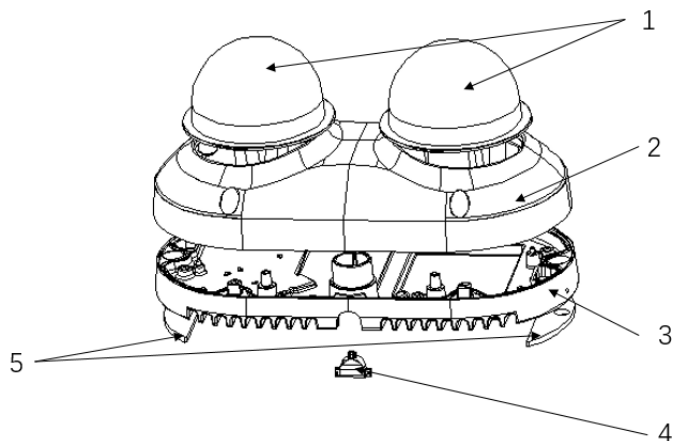

No.	Name	Material	Quantity
1	Lens guard	PC	2
2	Top housing	ADC12	1
3	Bot housing	ADC12	1
4	Sider cover	PC	1
5	Shock Pad	Silica gel	2

XM61:

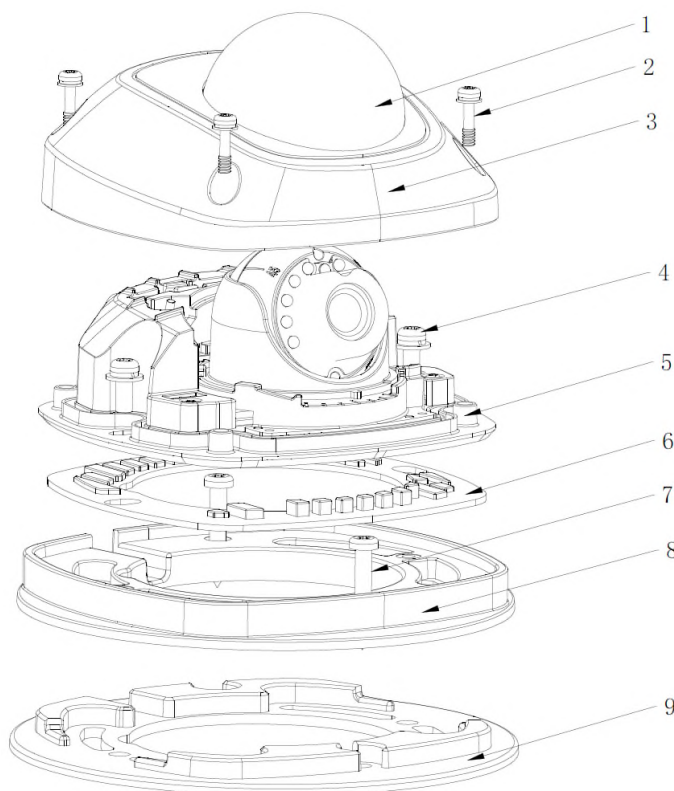

No.	Name	Material	Quantity
1	Cover of camera	PC	1
2	M3 Screw	SUS304	4
3	Cover assembly	ADC12(铝材)	1
4	M4 Screw	SUS304	2
5	Main Body	ADC12	1
6	Base Shock Pad	Silica gel	1
7	M4 Screw	SUS304	2
8	Transfer Disk	PC+10%GF	1
9	Transfer Disk Shock Pad	Silica gel	1



**HIKVISION**

Manufacturer : Hangzhou Hikvision Digital Technology Co., Ltd.

Type : DS-2XM6DX2G0-I/ND

XM62:

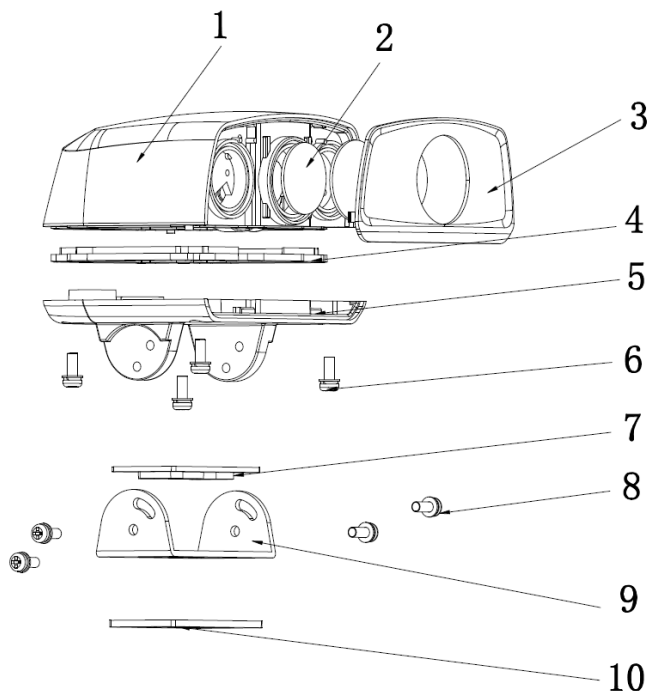

No.	Name	Material	Quantity
1	UP Cover of camera	ADC12(铝材)	1
2	Glass	Glass	3
3	IR cover	PC	1
4	SEAL RING	Silica gel	1
5	BASE	ADC12(铝材)	1
6	M3 Screw	SUS304	4
7	Plastic plate	PC	2
8	M3 Screw	SUS304	4
9	Bracket	SUS304	1
10	Silica plate	Silica gel	1

XM65:

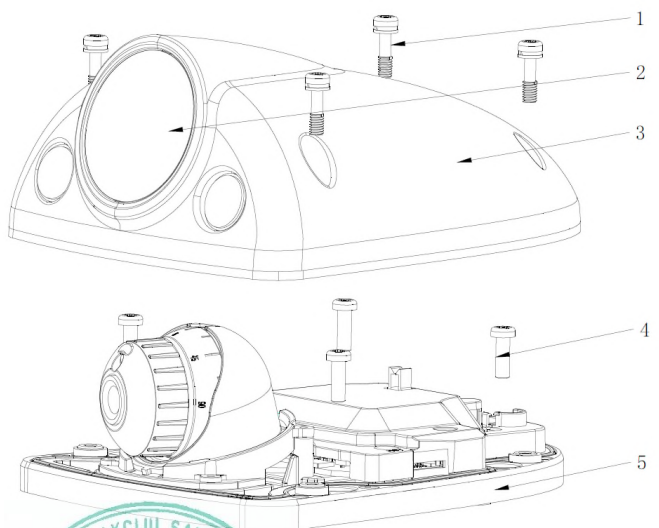

No.	Name	Material	Quantity
1	M4 Screw	SUS304	4
2	Cover of camera	PC	1
3	Cover assembly	ADC12(铝材)	1
4	M4 Screw	SUS304	4
5	Main Body	ADC12	1
6	Base Shock Pad	Silica gel	1



Type : DS-2XM6DX2G0-I/ND  
Manufacturer : Hangzhou Hikvision Digital Technology Co., Ltd.

Precisely Right.

## TEST REPORT

according to UN-Regulation

**Uniform provisions concerning the Burning Behaviour and/ or the capability to repel fuel or lubricant of materials used in the construction of certain categories of motor vehicles**

**Part II — Approval of a component with regard to its burning behaviour and/or its capability to repel fuel or lubricant installed in the interior compartment, the engine compartment or any separate heating compartment**

**UN-Regulation No. 118**

as last amended by

**Amend. 03, Suppl. 1**

Previously granted

UN approval : ---

Structure of the Test Report

Item No.

0. General information
1. Tested vehicle(s) / object(s)
2. Test record
3. List of appendices
4. Statement of conformity

The Test Report shall be reproduced and published in full by the client only. It shall however be reproduced partially with the written permission of the Technical Service only.

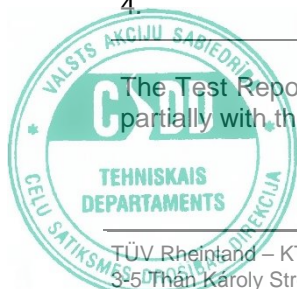



Type : DS-2XM6DX2G0-I/ND  
 Manufacturer : Hangzhou Hikvision Digital Technology Co., Ltd.

## 0. General information

- 0.1. Make (trade name of the manufacturer) : HIKVISION
- 0.2. Type : DS-2XM6DX2G0-I/ND
- 0.3. Category of vehicle : n.a.
- 0.4. Name and address of the manufacturer : Hangzhou Hikvision Digital Technology Co., Ltd.  
 No.555 Qianmo Road, Binjiang District,  
 Hangzhou City, Zhejiang Province, China
- 0.5. No. of the information folder : DS-2XM6DX2G0-I/ND-R118-00  
 - Date of issue : November 27, 2019  
 - Date of last change : --

## 1. Tested vehicle(s)/ object(s)

### 1.1. Description

1.1.1. ~~Vehicle~~ / object : [~~Vehicle~~] [Object]

Commercial description : DS-2XM6D82G0-I/ND, DS-2XM6D52G0-I/ND,  
 DS-2XM6122G0-I/ND, DS-2XM6112G0-I/ND,  
 DS-2XM6222G0-I/ND, DS-2XM6212G0-I/ND,  
 DS-2XM6522G0-I/ND, DS-2XM6512G0-I/ND

Type(s) ~~variant(s)~~ / ~~version(s)~~ : DS-2XM6DX2G0-I/ND

Identification number : n.a.

1.1.2. Condition of ~~vehicle(s)~~ / Object(s) : New / ~~used~~ / ~~pretested~~

1.2. Worst case selection : The determination of worst case was done according to internal procedure of the Technical Service (QMA 1.301.005, section 6.2.2.2)

1.3. Remarks : All versions of the ~~vehicle~~ / object type as stated in the information folder are covered by the ~~tested vehicle version(s)~~ and tested object(s) respectively.



Type : DS-2XM6DX2G0-I/ND  
 Manufacturer : Hangzhou Hikvision Digital Technology Co., Ltd.

## 2. Test record

- 2.1. Equipment for measuring and testing : The test facilities / measurement equipment used were in compliance with the test requirements.
- 2.1.1. Specifications for the test site : n.a.
- 2.1.2. Subcontracting : n.a.
- 2.2. Test results : Passed /~~failed~~
- 2.2.1. Horizontal burning behaviour : n.a.
- 2.2.2. Melting behaviour : n.a.
- 2.2.3. Vertical burning behavior : n.a.
- 2.2.4. Complete device : The complete device includes electrical cable and camera. The surface area of each element on camera made of non-metal is less than 300 cm<sup>2</sup>, so the camera is not required to undergo the tests of horizontal burning test, vertical burning test or melting behaviour test.
- 2.2.5. Repel fuel or lubricant : n.a.
- 2.2.6. Flame propagation test for electric cable : Flame is extinguish within 70s and not less than 50mm insulation at the top of the test sample is remain unburned.
- 2.2.7. Mark with trade name and type : The samples are clearly and indelibly marked with the applicant's trade name and the type designation.
- 2.2.8. Alternative test provisions : n.a.
- 2.2.9. Attributive tests : n.a.
- Remark concerning extension : ~~The type has been tested according to the modification(s) mentioned in appendix 0.~~  
~~The new parts meet the requirements of the regulation / directive.~~  
 An actual practical test of the type was not necessary. The results of the previous test(s) are still valid.
- 2.3. Additional information : The results of the test refer exclusively to the object(s) mentioned under point 1.1. of this report.
- Test site : Automotive Component Testing Center of Ningbo  
 No. 99, Jingu South Road, Yinzhou Investment & Business Incubation, 315104, Ningbo, P.R. China
- Test date : December 23, 2019
- 2.4. Remarks : --



Type : DS-2XM6DX2G0-I/ND  
Manufacturer : Hangzhou Hikvision Digital Technology Co., Ltd.

---

### 3. List of Appendices

Appendix 0 : List of modifications  
Appendix 1 : Test result  
Information folder no. : DS-2XM6DX2G0-I/ND-R118-00

### 4. Statement of conformity

The in point 0.5. mentioned information folder and the type described in that comply with the requirements mentioned on page 1.

With regard to the required level of performance to be achieved, the tested items were representative for the type to be approved (see point 1.2).

The mentioned test results refer to the ~~vehicle(s)~~ object(s) described under point 1.1 of this report.

Engineering centre Shanghai / January 02, 2020  
EY



Emma Yu  
Expert Technical Service



Type : DS-2XM6DX2G0-I/ND  
Manufacturer : Hangzhou Hikvision Digital Technology Co., Ltd.

---

Precisely Right.

List of modifications

Appendix 0

Correction of : ---  
Modification of : ---  
Addition of : ---  
Deletion of : ---



Type : DS-2XM6DX2G0-I/ND  
 Manufacturer : Hangzhou Hikvision Digital Technology Co., Ltd.

## Test result

## Appendix 1

## Flame propagation test for electric cable

Specimen	Dimension (mm)	Burning duration (s)	Unburnt length at the top (mm)	Remark
1	> 600	3.6	413	--
2	> 600	4.8	421	--
3	> 600	5.5	419	--
4	> 600	7.6	420	--
5	> 600	10.0	415	--



TUV Rheinland - KTI Ltd.  
 3-5 Thán Károly Street.  
 1139 Budapest  
 HUNGARY

Telephone: +36-1-371-5948, +36-1-205-5881  
 Telefax: +36-1-203-1167