



TEST REPORT

Application No.: SHEM1906013867AT
Applicant: Hangzhou Hikvision Digital Technology Co., Ltd
Address of Applicant: No.555 Qianmo Road, Binjiang District, Hangzhou 310052, China
Manufacturer: Hangzhou Hikvision Digital Technology Co., Ltd.
Address of Manufacturer: No.555 Qianmo Road, Binjiang District, Hangzhou 310052, China
Factory: 1, Hangzhou Hikvision Technology Co., Ltd.
2, Hangzhou Hikvision Electronics Co., Ltd.
3, Hangzhou Hikvision Digital Technology Co., Ltd.
4, Chongqing Hikvision technology Co., Ltd.
Address of Factory: 1, No.700, Dongliu Road, Binjiang District, Hangzhou City, Zhejiang, 310052, China
2, No.299, Qiushi Road, Tonglu Economic Development Zone, Tonglu County, Hangzhou, Zhejiang, 310052, China.
3, No. 555 Qianmo Road, Binjiang District, Hangzhou 310052, China
4, No. 118, Haikang Road, Area C, Jianqiao Industrial Park, Dadukou District, Chongqing, 401325,China
Equipment Under Test (EUT):
EUT Name: Digital Video Recorder
Model No.: iDS-7216HQHI-M1/S, iDS-7216HQHI-M1/S/UHK,
iDS-7216HQHI-M1/S/CKV, iDS-7216HQHI-M1/S/UVS,
iDS-7216HQHI-M1/S/KVO, iDS-7216HQHI-M1/S/HUN,
iDS-7216HQHI-M1/S/A, iDS-7216HQHI-K1/4S
Standard(s): EN 55032:2015, EN 50130-4:2011 +A1:2014
EN 61000-3-2:2014, EN 61000-3-3:2013
Date of Receipt: 2019-05-10
Date of Test: 2019-05-13 to 2019-05-20
Date of Issue: 2019-06-11

Table with 2 columns: Test Result, Pass*

* In the configuration tested, the EUT complied with the standards specified above.

The CE mark as shown below can be used, under the responsibility of the manufacturer, after completion of an EU Declaration of Conformity and compliance with all relevant EU Directives.

Handwritten signature: Parlam Zhan

Parlam Zhan
E&E Section Manager



The manufacturer should ensure that all products in series production are in conformity with the product sample detailed in this report. If the product in this report is used in any configuration other than that detailed in the report, the manufacturer must ensure the new system complies with all relevant standards. Any mention of SGS International Electrical Approvals or testing done by SGS International Electrical Approvals in connection with, distribution or use of the product described in this report must be approved by SGS International Electrical Approvals in writing.





Unless otherwise agreed in writing, this document is issued by the Company subject to its General Conditions of Service printed overleaf, available on request or accessible at http://www.sgs.com/en/Terms-and-Conditions.aspx and, for electronic format documents, subject to Terms and Conditions for Electronic Documents at http://www.sgs.com/en/Terms-and-Conditions/Terms-e-Documents.aspx. Attention is drawn to the limitation of liability, indemnification and jurisdiction issues defined therein. Any holder of this document is advised that information contained hereon reflects the Company's findings at the time of its intervention only and within the limits of Client's instructions, if any. The Company's sole responsibility is to its Client and this document does not exonerate parties to a transaction from exercising all their rights and obligations under the transaction documents. This document cannot be reproduced except in full, without prior written approval of the Company. Any unauthorized alteration, forgery or falsification of the content or appearance of this document is unlawful and offenders may be prosecuted to the fullest extent of the law. Unless otherwise stated the results shown in this test report refer only to the sample(s) tested and such sample(s) are retained for 30 days only. Attention: To check the authenticity of testing/inspection report & certificate, please contact us at telephone: (86-755) 8307 1443, or email: CN.Doccheck@sgs.com
NO.588 West Jindu Road, Songjiang District, Shanghai, China 201612
中国·上海·松江区金都西路588号 邮编: 201612



SGS-CSTC Standards Technical Services (Shanghai) Co., Ltd.

Report No.: SHEM190601386701
Page: 2 of 68

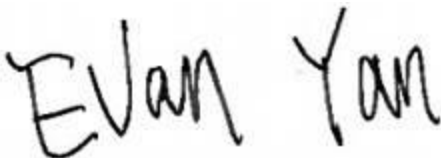
Revision Record			
Version	Description	Date	Remark
00	Original	2019-06-11	/

Authorized for issue by:				
				
		<hr/>		
		Evan Yan / Project Engineer		
				
		<hr/>		
		Bruce Tang / Reviewer		

2 Test Summary

Emission Part				
Item	Standard	Method	Requirement	Result
Conducted Emissions at Mains Terminals (150kHz-30MHz)	EN 55032:2015	EN 55032:2015	Class B	Pass
Asymmetric Mode Conducted Emissions (150kHz-30MHz)	EN 55032:2015	EN 55032:2015	Class B	Pass
Radiated Emissions (30MHz-1GHz)	EN 55032:2015	EN 55032:2015	Class B	Pass
Radiated Emissions (above 1GHz)	EN 55032:2015	EN 55032:2015	Class B	Pass
Harmonic Current Emission	EN 61000-3-2:2014	EN 61000-3-2:2014	Class A	N/A*
Voltage Fluctuations and Flicker	EN 61000-3-3:2013	EN 61000-3-3:2013	Clause 5 of EN 61000-3-3	Pass
Immunity Part				
Item	Standard	Method	Requirement	Result
Electrostatic Discharge	EN 50130-4:2011 +A1:2014	EN 61000-4-2:2009	6kV Contact Discharge 2,4,8kV Air Discharge	Pass
Electrical Fast Transients/Burst at Power Port	EN 50130-4:2011 +A1:2014	EN 61000-4-4:2012	2kV 5/50ns Tr/Td 100kHz Repetition Frequency	Pass
Electrical Fast Transients/Burst at Signal Port	EN 50130-4:2011 +A1:2014	EN 61000-4-4:2012	1kV 5/50ns Tr/Td 100kHz Repetition Frequency	Pass
Surge at Power Port	EN 50130-4:2011 +A1:2014	EN 61000-4-5:2014	1.2/50µs Tr/Td 0.5,1kV Line to Line 0.5,1,2kV Line to Ground	Pass
Surge at Signal Port	EN 50130-4:2011 +A1:2014	EN 61000-4-5:2014	1.2/50µs Tr/Td 0.5,1kV Line to Ground	Pass
Voltage Dips and Interruptions	EN 50130-4:2011 +A1:2014	EN 61000-4-11:2004	80 % UT for 250per 70 % UT for 25per 40 % UT for 10per 0 % UT for 250per UT is Supply Voltage	Pass
Mains Supply Voltage Variations-Conditioning	EN 50130-4:2011 +A1:2014	EN 50130-4:2011+A1:2014	Unom+10% Unom-15%	Pass
Radiated Immunity(80MHz-2.7GHz)	EN 50130-4:2011 +A1:2014	EN 61000-4-3:2006 +A1:2008+A2:2010	10V/m, 80%, 1kHz sinusoidal Amp. Mod.	Pass

Conducted Immunity at Power Port (150kHz-100MHz)	EN 50130-4:2011 +A1:2014	EN 61000-4-6:2014	10Vrms (emf),80%,1kHz sinusoidal Amp. Mod.	Pass
Conducted Immunity at Signal Port (150kHz-100MHz)	EN 50130-4:2011 +A1:2014	EN 61000-4-6:2014	10Vrms (emf),80%,1kHz sinusoidal Amp. Mod.	Pass

N/A*: Not applicable. Please refer to section 6.5 of this report for more details.

InternalSource	UpperFrequency
Below 108MHz	1GHz
108MHz to 500MHz	2GHz
500MHz to 1GHz	5GHz
Above 1GHz	5 times the highest frequency or 6 GHz, whichever is less

Note1: Declaration of EUT Family Grouping:

There are series models mentioned in this report and they are the similar in electrical and electronic characters. Only the model iDS-7216HQHI-M1/S was tested since their differences are model number.

3 Contents

	Page
1 COVER PAGE.....	1
2 TEST SUMMARY.....	3
3 CONTENTS	5
4 GENERAL INFORMATION.....	7
4.1 DETAILS OF E. U. T.....	7
4.2 DESCRIPTION OF SUPPORT UNITS	7
4.3 MEASUREMENT UNCERTAINTY	8
4.4 TEST LOCATION	9
4.5 TEST FACILITY	9
4.6 DEVIATION FROM STANDARDS.....	9
4.7 ABNORMALITIES FROM STANDARD CONDITIONS	9
4.8 MONITORING OF EUT FOR ALL IMMUNITY TEST.....	9
5 EQUIPMENT LIST.....	10
6 EMISSION TEST RESULTS.....	12
6.1 CONDUCTED EMISSIONS AT MAINS TERMINALS (150KHZ-30MHZ).....	12
6.2 ASYMMETRIC MODE CONDUCTED EMISSIONS (150KHZ-30MHZ)	17
6.3 RADIATED EMISSIONS (30MHZ-1GHZ)	24
6.4 RADIATED EMISSIONS (ABOVE 1GHZ).....	27
6.5 HARMONIC CURRENT EMISSION.....	30
6.6 VOLTAGE FLUCTUATIONS AND FLICKER.....	31
7 IMMUNITY TEST RESULTS.....	33
7.1 PERFORMANCE CRITERIA DESCRIPTION IN EN 50130-4:2011 +A1:2014.....	33
7.2 ELECTROSTATIC DISCHARGE.....	34
7.3 ELECTRICAL FAST TRANSIENTS/BURST AT POWER PORT.....	36
7.4 ELECTRICAL FAST TRANSIENTS/BURST AT SIGNAL PORT.....	37
7.5 SURGE AT POWER PORT	38
7.6 SURGE AT SIGNAL PORT	40
7.7 VOLTAGE DIPS AND INTERRUPTIONS.....	41
7.8 MAINS SUPPLY VOLTAGE VARIATIONS-CONDITIONING	43
7.9 RADIATED IMMUNITY (80MHZ-2.7GHZ)	44
7.10 CONDUCTED IMMUNITY AT POWER PORT (150KHZ-100MHZ).....	45
7.11 CONDUCTED IMMUNITY AT SIGNAL PORT (150KHZ-100MHZ).....	46
8 PHOTOGRAPHS.....	48
8.1 CONDUCTED EMISSIONS AT MAINS TERMINALS (150KHZ-30MHZ) TEST SETUP	48
8.2 ASYMMETRIC MODE CONDUCTED EMISSIONS (150KHZ-30MHZ) TEST SETUP.....	49
8.3 RADIATED EMISSIONS (30MHZ-1GHZ) TEST SETUP.....	50
8.4 RADIATED EMISSIONS (ABOVE 1GHZ) TEST SETUP	50
8.5 VOLTAGE FLUCTUATIONS AND FLICKER TEST SETUP	51
8.6 ELECTROSTATIC DISCHARGE TEST SETUP.....	51
8.7 RADIATED IMMUNITY (80MHZ-2.7GHZ) TEST SETUP.....	52
8.8 ELECTRICAL FAST TRANSIENTS/BURST AT POWER PORT TEST SETUP	53
8.9 ELECTRICAL FAST TRANSIENTS/BURST AT SIGNAL PORT TEST SETUP	53
8.10 SURGE AT POWER PORT TEST SETUP.....	54



SGS-CSTC Standards Technical Services (Shanghai) Co., Ltd.

Report No.: SHEM190601386701
Page: 6 of 68

8.11	SURGE AT SIGNAL PORT TEST SETUP.....	55
8.12	CONDUCTED IMMUNITY AT POWER PORT (150KHZ-100MHZ) TEST SETUP	57
8.13	CONDUCTED IMMUNITY AT SIGNAL PORT (150KHZ-100MHZ) TEST SETUP	57
8.14	VOLTAGE DIPS AND INTERRUPTIONS TEST SETUP.....	58
8.15	MAINS SUPPLY VOLTAGE VARIATIONS-CONDITIONING TEST SETUP.....	58
8.16	EUT CONSTRUCTIONAL DETAILS (EUT PHOTOS)	59

4 General Information

4.1 Details of E.U.T.

Power supply:	AC 220V Adapter: 101700700, MSA-C2000IC12.0-24P-DE, 12V2A, Φ2.1 101700702, MSA-C2000IC12.0-24P-GB, 12V2A, Φ2.1 101700704, MSA-C2000IC12.0-24P-AU, 12V2A, Φ2.1 101700729, MSA-C2000IC12.0-24P-BR, 12V2A, Φ2.1 101700708, ADS-26FSG-12 12024EPG, 12V2A, Φ2.1 101700710, ADS-26FSG-12 12024EPB, 12V2A, Φ2.1 ADS-26FSG-12 12024EPSA ADS-26FSG-12 12024EPBR 101701110, ADS-26FSG-12 12024EPK, 12V2A, Φ2.1 101701062, ADS-26FSG-12 12024EPA, 12V2A
Cables:	Interface: Power*1, Video in*16, Lan*1, Audio in*16, Audio out*1, Alarm in*8, Alarm out*1, HDMI*1, VGA*1, USB2.0*2, RS485*1 Cable length:LAN cable (unshielded) 2m, BNC cable 3m , Power cable 1.5m

4.2 Description of Support Units

Description	Manufacturer	Model No.
Monitor	SAMSUNG	SMT-2233/CH
Notebook	Lenovo	L480
Notebook	HP	HP ProBook 440 G5
Digital Camera	Hikvision	DS-2CE16D3T-I3F
Digital Camera	Hikvision	DS-2CE56D1T-I
HDMI Cable	/	2m
VGA Cable	/	2m
BNC Cable	/	3m

4.3 Measurement Uncertainty

No.	Item	Measurement Uncertainty
1	Conducted Emission at mains port using AMN	±2.6dB (9kHz to 150kHz)
		±2.3dB (150kHz to 30MHz)
2	Conducted Emission at mains port using VP	±1.9 dB (9kHz to 30MHz)
3	Conducted Emission at telecommunication port using AAN	±4.1 dB (150kHz to 30MHz)
4	Radiated Power	±3.0dB
5	Radiated emission	±4.4dB (30MHz-1GHz)
		±4.8dB (1GHz-6GHz)
		±5.2dB (6GHz-18GHz)

Note: The measurement uncertainty represents an expanded uncertainty expressed at approximately the 95% confidence level using a coverage factor of k=2.

4.4 Test Location

SGS-CSTC Standards Technical Services (Shanghai) Co., Ltd. E&E Lab

588 West Jindu Road, Xinqiao, Songjiang, 201612 Shanghai, China

Tel: +86 21 6191 5666 Fax: +86 21 6191 5678

sub-contracted

Hangzhou Hikvision Digital Technology Co., Ltd

No.555 Qianmo Road, Binjiang District, Hangzhou 310052, China

4.5 Test Facility

The test facility is recognized, certified, or accredited by the following organizations:

- **CNAS (No. CNAS L0599)**

CNAS has accredited SGS-CSTC Standards Technical Services (Shanghai) Co., Ltd. to ISO/IEC 17025:2005 General Requirements for the Competence of Testing and Calibration Laboratories (CNAS-CL01 Accreditation Criteria for the Competence of Testing and Calibration Laboratories) for the competence in the field of testing.

- **NVLAP (Certificate No. 201034-0)**

SGS-CSTC Standards Technical Services (Shanghai) Co., Ltd. is accredited by the National Voluntary Laboratory Accreditation Program(NVLAP). Certificate No. 201034-0.

- **FCC –Designation Number: CN5033**

SGS-CSTC Standards Technical Services (Shanghai) Co., Ltd. has been recognized as an accredited testing laboratory.

Designation Number: CN5033. Test Firm Registration Number: 479755.

- **Innovation, Science and Economic Development Canada**

SGS-CSTC Standards Technical Services (Shanghai) Co., Ltd. EMC Laboratory has been recognized by ISED as an accredited testing laboratory.

IC Registration No.: 8617A-1. CAB Identifier: CN0020.

- **VCCI (Member No.: 3061)**

The 3m Semi-anechoic chamber and Shielded Room of SGS-CSTC Standards Technical Services (Shanghai) Co., Ltd. has been registered in accordance with the Regulations for Voluntary Control Measures with Registration No.: R-13868, C-14336, T-12221, G-10830 respectively.

4.6 Deviation from Standards

None

4.7 Abnormalities from Standard Conditions

None

4.8 Monitoring of EUT for All Immunity Test

Visual: work status and video quality

5 Equipment List

Conducted Emissions at Mains Terminals					
Equipment	Manufacturer	Model NO	Serial NO.	Cal Date	Cal Due Date
EMI test Receiver	R&S	ESR3	101831	2019/5/5	2020/5/4
Line impedance stabilization network	R&S	ENV216	10107	2019/5/5	2020/5/4
Radiated Emission					
Equipment	Manufacturer	Model NO	Serial NO.	Cal Date	Cal Due Date
EMI test Receiver	R&S	ESU26	100499	2018/12/11	2019/12/11
PRE-Amplifier	Connphy	CLN-1G18G-4030-S	517002	2018/8/30	2019/8/30
TRLIOG Broad Band Antenna	Schwarzbeck	VULB 9168	796	2017/7/10	2019/7/10
Horn antenna	Schwarzbeck	BBHA 9120D	7794	2017/8/19	2019/8/19
Voltage Fluctuations and Flicker					
Equipment	Manufacturer	Model NO	Serial NO.	Cal Date	Cal Due Date
Harmonic & Flicker analyzer	TESEQ	NSG1007	1438A04118-1	2019/5/22	2020/5/21
AC power source	TESEQ	CCN1000-1	1438A04118-1	2019/5/22	2020/5/21
Electrostatic Discharge					
Equipment	Manufacturer	Model NO	Serial NO.	Cal Date	Cal Due Date
Electrostatic Discharge Simulator	TESEQ	NSG 437	1254	2018/7/4	2019/7/3
EFT					
Equipment	Manufacturer	Model NO	Serial NO.	Cal Date	Cal Due Date
Immunity Test system	TESEQ	NSG3040	2173	2019/5/5	2020/5/4
Capacitive coupling clamp	TESEQ	CDN 3425	1928	2019/5/5	2020/5/4
Surge					
Immunity Test system	TESEQ	NSG3060	1716	2019/5/5	2020/5/4
Data coupling network	TESEQ	CDN 117M	38777	2019/5/5	2020/5/4
Power coupling network	TESEQ	CDN 3061-S16	1513	2019/5/5	2020/5/4
Immunity Test system	3C test	SG-728G	EC0630906	2018/11/09	2019/11/08
Immunity Test system	3C test	SG-5006G	EC5580932	2018/11/09	2019/11/08
Data coupling network	3C test	SGN-C3	EC5620903	2018/11/09	2019/11/08
Power coupling network	3C test	SGN-5010G	EC5590919	2018/11/09	2019/11/08
Data coupling network	3C test	SGN-C2	EC5620903	2018/11/09	2019/11/08
CS					



SGS-CSTC Standards Technical Services (Shanghai) Co., Ltd.

Report No.: SHEM190601386701

Page: 11 of 68

Immunity Test system	TESEQ	NSG 4070C-0	47944	2019/4/2	2020/4/1
CDN	TESEQ	CDN M016	50365	2019/4/2	2020/4/1
Coupling clamp	TESEQ	KEMZ 801A	50113	2019/4/2	2020/4/1
RS					
Signal generator	keysight	N5181A	MY50146343	2018/11/09	2019/11/08
Power meter	keysight	N1914A	MY55336002	2018/11/09	2019/11/08
Amplifier	milmege	80RF1000-500	1069892	2018/11/09	2019/11/08
Amplifier	milmege	AS0827-230	1069893	2018/11/09	2019/11/08
Antenna	Schwarzbeck	STLP9128E	9128E7#3009	/	/
Antenna	Schwarzbeck	STLP 9149	9149-349	/	/
DIP & Mains Supply Voltage Variations -conditioning					
Immunity Test system	TESEQ	NSG3040	2173	2019/5/5	2020/5/4
	TESEQ	VAR 3005-D16	2018	2019/5/5	2020/5/4
Other					
Equipment	Manufacturer	Model NO	Serial NO.	Cal Date	Cal Due Date
Temperature&humidity recorder	PINYI	HTC-1	/	2018/7/19	2019/7/18
Pressure meter	YIOU	BY-2003P	E01406062	2018/11/27	2019/11/26

6 Emission Test Results

6.1 Conducted Emissions at Mains Terminals (150kHz-30MHz)

Test Requirement:	EN 55032:2015
Test Method:	EN 55032:2015
Frequency Range:	150kHz to 30MHz
Limit:	
0.15M-0.5MHz	66dB(μV)-56dB(μV) quasi-peak, 56dB(μV)-46dB(μV) average
0.5M-5MHz	56dB(μV) quasi-peak, 46dB(μV) average
5M-30MHz	60dB(μV) quasi-peak, 50dB(μV) average
Detector:	Peak for pre-scan (9kHz resolution bandwidth) 0.15M to 30MHz

6.1.1 E.U.T. Operation

Operating Environment:

Temperature: 26 °C Humidity: 58 % RH Atmospheric Pressure: 1022.2 mbar

Test mode: a: Typical configuration: Keep EUT monitoring and data running continual, recording video during the test. Powered by power ADS-26FSG-12 12024EPG.

b: Typical configuration: Keep EUT monitoring and data running continual, recording video during the test. Powered by power MSA-C2000IC12.0-24P-DE

6.1.2 Test Setup Diagram

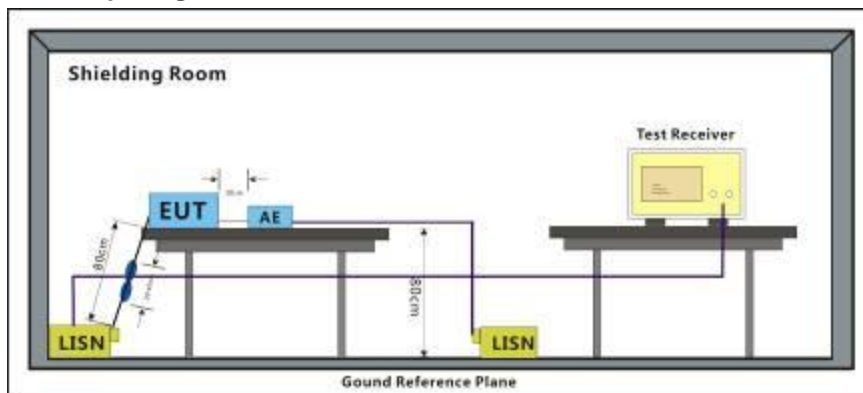

6.1.3 Measurement Data

An initial pre-scan was performed with peak detector. Quasi-Peak or Average measurement were performed at the frequencies with maximized peak emission were detected.

Notes : Emission Level=Read Level + LISN Factor + Cable Loss

Mode:a; Line:Live Line

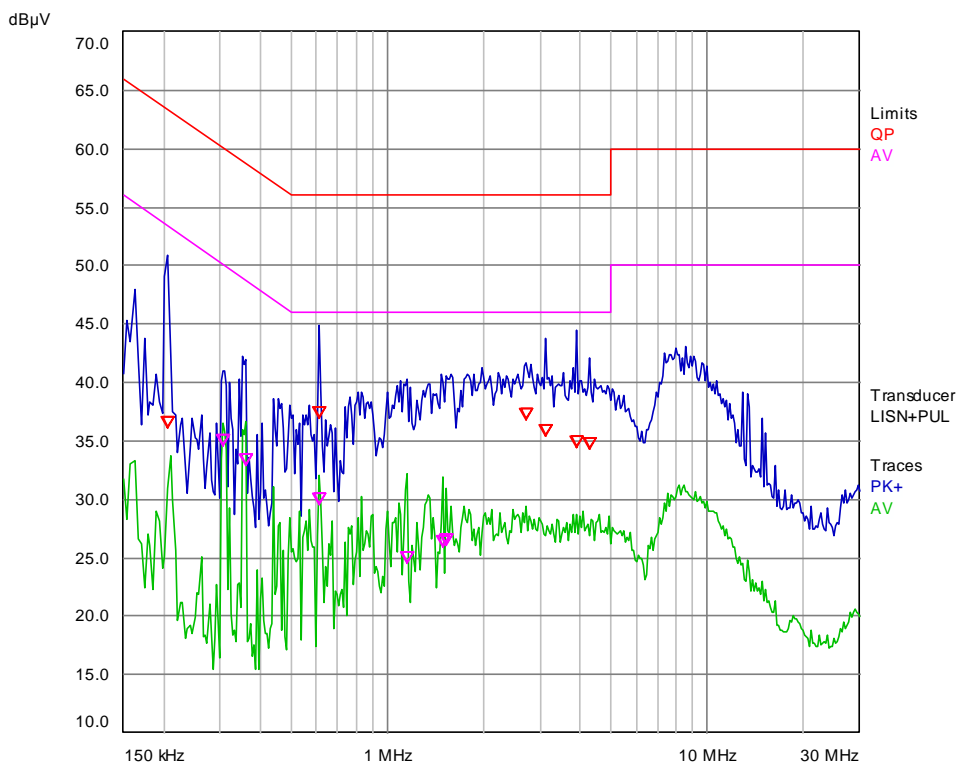

Final Measurement Results

Trace	Frequency (MHz)	Level (dBµV)	Limit (dBµV)	Delta Limit (dB)	Comment
1 QP	0.206	36.05	63.37	-27.32	L1 / on
2 CA	0.306	34.54	50.08	-15.54	L1 / on
2 CA	0.362	32.95	48.68	-15.73	L1 / on
1 QP	0.61	36.95	56.00	-19.05	L1 / on
2 CA	0.614	29.48	46.00	-16.52	L1 / on
2 CA	1.15	24.45	46.00	-21.55	L1 / on
2 CA	1.494	25.89	46.00	-20.11	L1 / on
2 CA	1.53	26.08	46.00	-19.92	L1 / on
1 QP	2.698	36.72	56.00	-19.28	L1 / on
1 QP	3.138	35.40	56.00	-20.60	L1 / on
1 QP	3.91	34.45	56.00	-21.55	L1 / on
1 QP	4.274	34.21	56.00	-21.79	L1 / on

* = limit exceeded

Mode:a; Line:Neutral Line

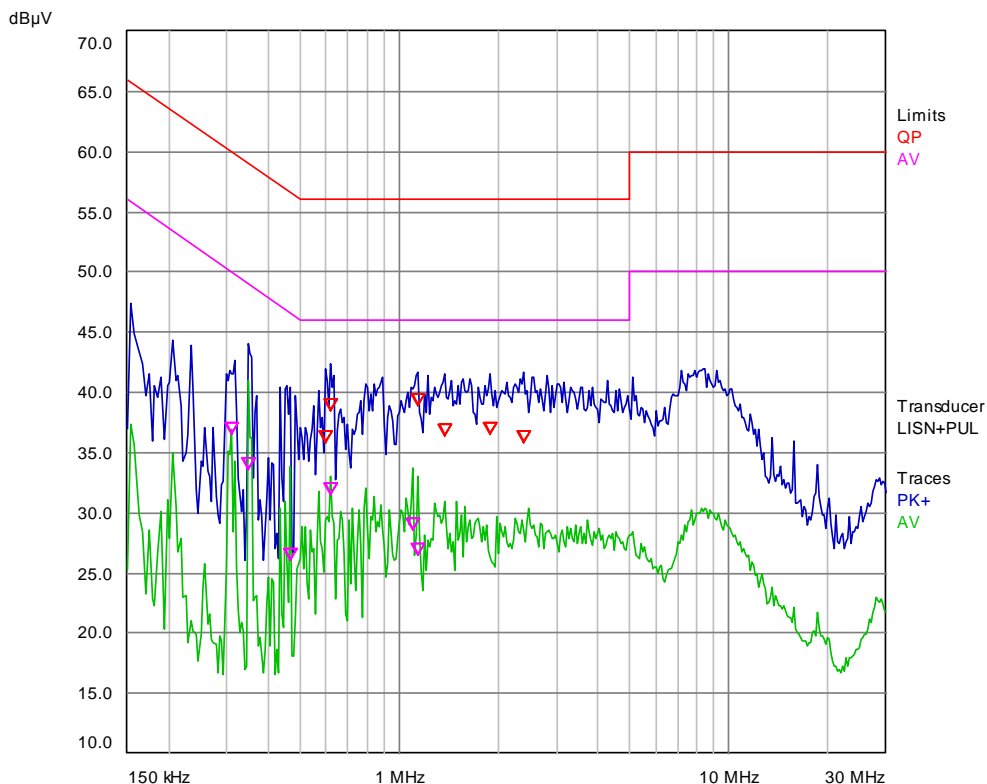

Final Measurement Results

Trace	Frequency (MHz)	Level (dBµV)	Limit (dBµV)	Delta Limit (dB)	Comment
2 CA	0.31	36.50	49.97	-13.47	N / on
2 CA	0.35	33.51	48.96	-15.45	N / on
2 CA	0.47	26.00	46.51	-20.51	N / on
1 QP	0.598	35.82	56.00	-20.18	N / on
2 CA	0.618	31.50	46.00	-14.50	N / on
1 QP	0.622	38.48	56.00	-17.52	N / on
2 CA	1.102	28.49	46.00	-17.51	N / on
2 CA	1.134	26.51	46.00	-19.49	N / on
1 QP	1.146	38.86	56.00	-17.14	N / on
1 QP	1.382	36.30	56.00	-19.70	N / on
1 QP	1.882	36.49	56.00	-19.51	N / on
1 QP	2.374	35.82	56.00	-20.18	N / on

* = limit exceeded

Mode:b; Line:Live Line

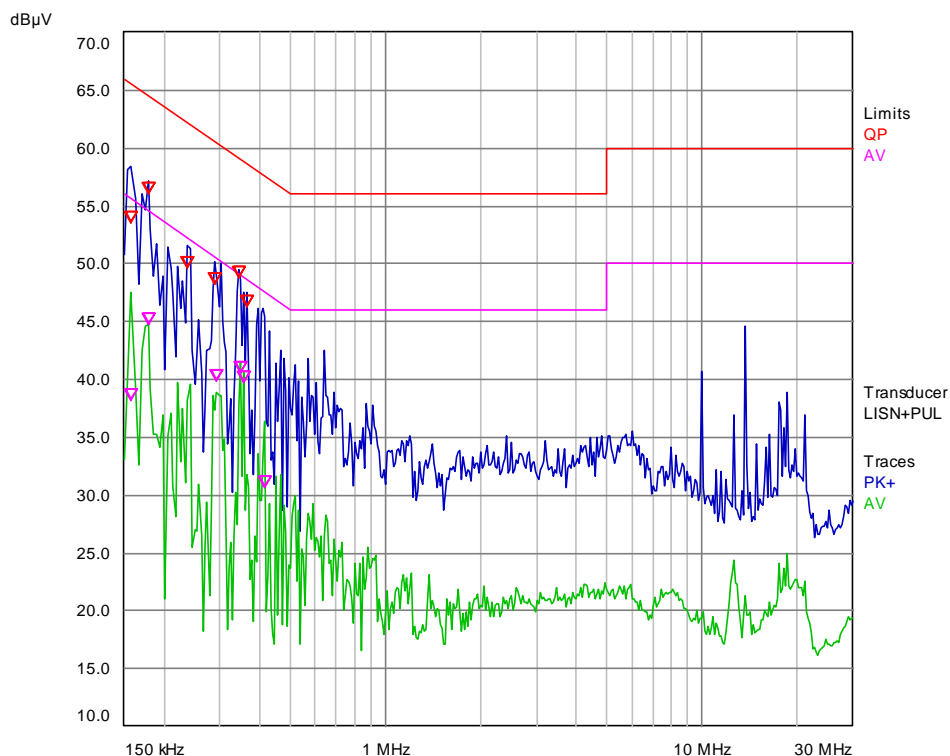

Final Measurement Results

Trace	Frequency (MHz)	Level (dBµV)	Limit (dBµV)	Delta Limit (dB)	Comment
1 QP	0.158	53.53	65.57	-12.04	L1 / on
2 CA	0.158	38.14	55.57	-17.43	L1 / on
1 QP	0.178	56.11	64.58	-8.47	L1 / on
2 CA	0.178	44.75	54.58	-9.83	L1 / on
1 QP	0.238	49.59	62.17	-12.58	L1 / on
1 QP	0.29	48.18	60.52	-12.34	L1 / on
2 CA	0.294	39.80	50.41	-10.61	L1 / on
1 QP	0.346	48.83	59.06	-10.23	L1 / on
2 CA	0.35	40.53	48.96	-8.43	L1 / on
2 CA	0.358	39.75	48.77	-9.02	L1 / on
1 QP	0.366	46.22	58.59	-12.37	L1 / on
2 CA	0.418	30.67	47.49	-16.82	L1 / on

* = limit exceeded

Mode:b; Line:Neutral Line

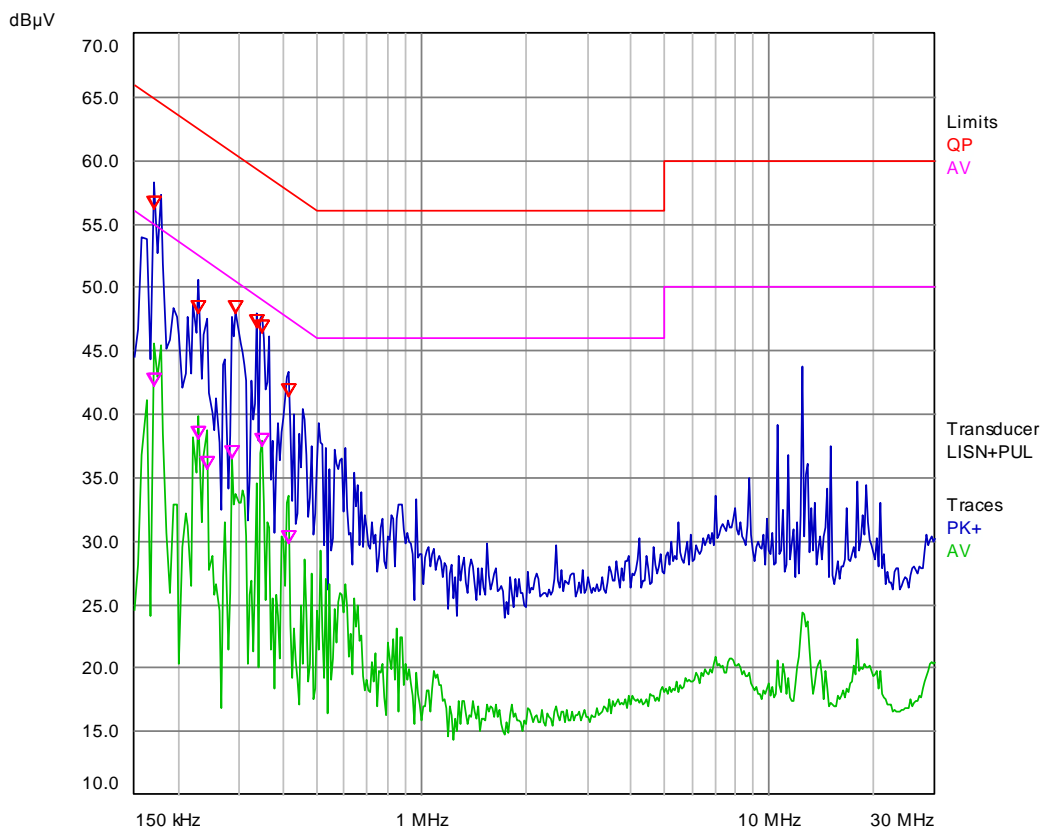

Final Measurement Results

Trace	Frequency (MHz)	Level (dBµV)	Limit (dBµV)	Delta Limit (dB)	Comment
1 QP	0.17	56.19	64.96	-8.77	N / on
2 CA	0.17	42.24	54.96	-12.72	N / on
1 QP	0.23	48.01	62.45	-14.44	N / on
2 CA	0.23	38.03	52.45	-14.42	N / on
2 CA	0.242	35.66	52.03	-16.37	N / on
2 CA	0.286	36.49	50.64	-14.15	N / on
1 QP	0.294	47.96	60.41	-12.45	N / on
1 QP	0.338	46.80	59.25	-12.45	N / on
1 QP	0.35	46.42	58.96	-12.54	N / on
2 CA	0.35	37.51	48.96	-11.45	N / on
1 QP	0.418	41.37	57.49	-16.12	N / on
2 CA	0.418	29.88	47.49	-17.61	N / on

* = limit exceeded

6.2 Asymmetric Mode Conducted Emissions (150kHz-30MHz)

Test Requirement: EN 55032:2015
Test Method: EN 55032:2015
Frequency Range: 150kHz to 30MHz

Limit:

0.15M-0.5MHz(Voltage)	84-74(dB μ V) quasi-peak; 74-64(dB μ V) average
0.5M-30MHz(Voltage)	74(dB μ V) quasi-peak; 64(dB μ V) average
0.15M-0.5MHz(Current)	40-30(dB μ V) quasi-peak; 30-20(dB μ V) average
0.5M-30MHz(Current)	30(dB μ V) quasi-peak; 20(dB μ V) average

Detector: 9kHz resolution bandwidth 0.15M to 30MHz

Remark: The voltage measured shall be corrected at each frequency of interest as follows:

if the current margin with respect to the current limit is ≤ 6 dB, the actual current margin shall be subtracted from the measured voltage;

if the current margin with respect to the current limit is > 6 dB, 6 dB shall be subtracted from the measured voltage.

6.2.1 E.U.T. Operation

Operating Environment:

Temperature: 26 °C Humidity: 58 % RH Atmospheric Pressure: 1022.2 mbar

Test mode a: Typical configuration: Keep EUT monitoring and data running continual, recording video during the test. Powered by power ADS-26FSG-12 12024EPG.

b: Typical configuration: Keep EUT monitoring and data running continual, recording video during the test. Powered by power MSA-C2000IC12.0-24P-DE

6.2.2 Test Setup Diagram

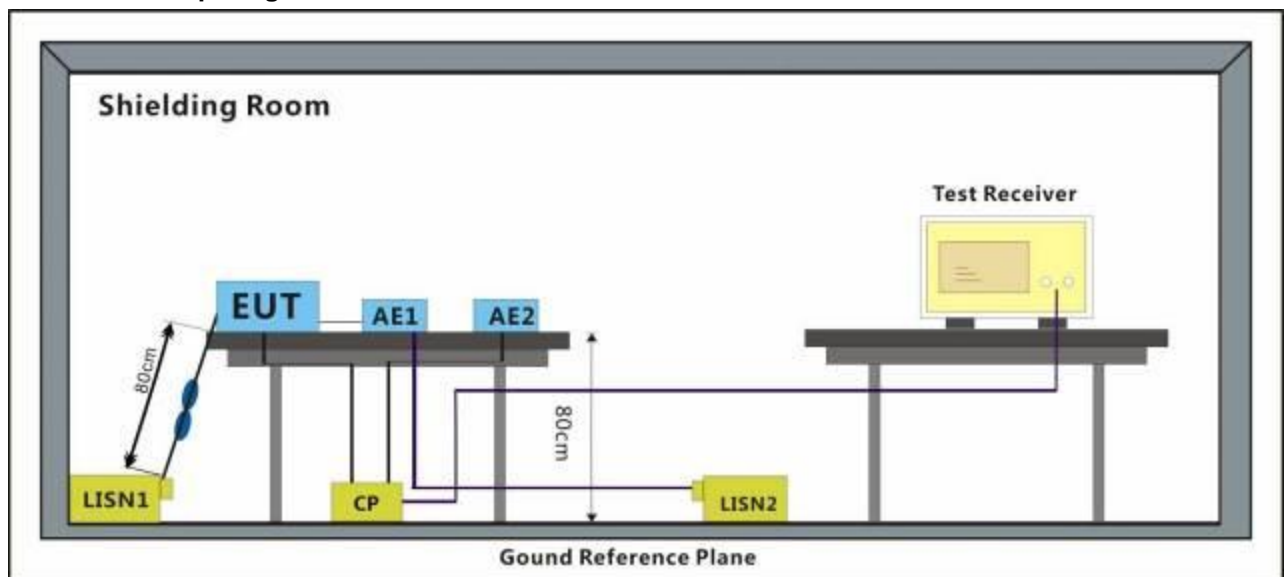

6.2.3 Measurement Data

Notes : Emission Level=Read Level + LISN Factor + Cable Loss

Mode a :
10Mbps

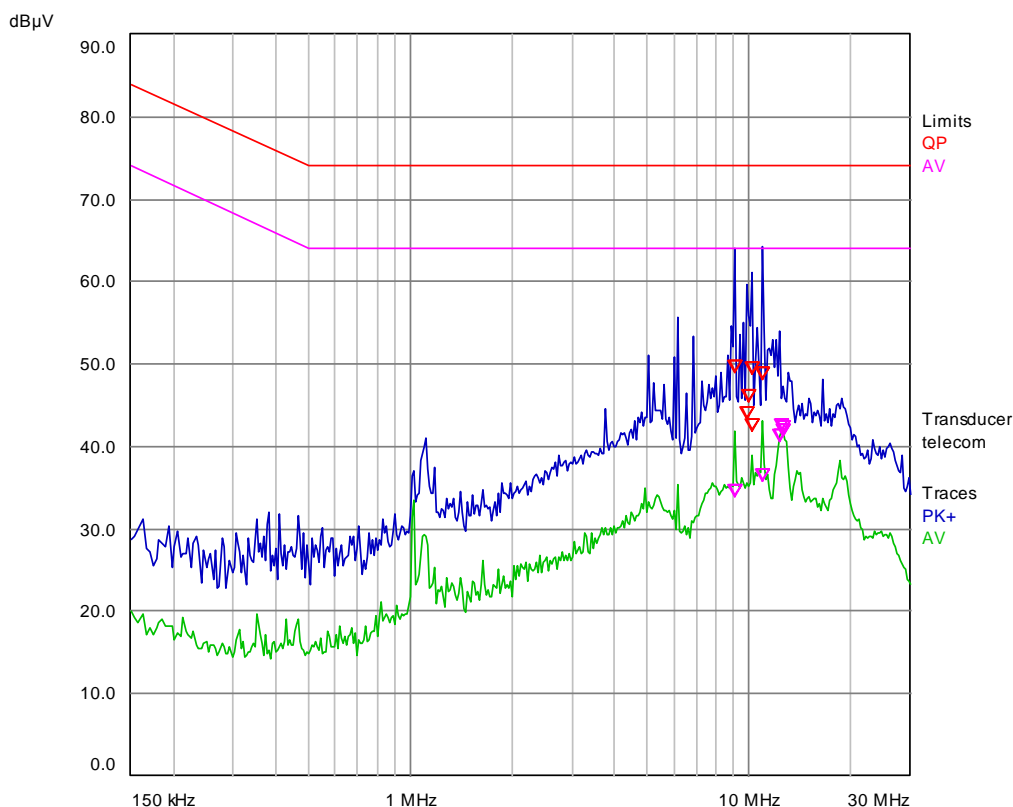

Final Measurement Results

Trace	Frequency (MHz)	Level (dBµV)	Limit (dBµV)	Delta Limit (dB)
1 QP	9.078	49.07	74.00	-24.93
2 CA	9.078	33.92	64.00	-30.08
1 QP	9.826	43.41	74.00	-30.59
1 QP	9.946	45.52	74.00	-28.48
1 QP	10.166	48.77	74.00	-25.23
1 QP	10.19	41.80	74.00	-32.20
1 QP	10.926	48.11	74.00	-25.89
2 CA	10.926	35.77	64.00	-28.23
2 CA	12.35	40.59	64.00	-23.41
2 CA	12.454	41.86	64.00	-22.14
2 CA	12.554	41.18	64.00	-22.82
2 CA	12.658	41.74	64.00	-22.26

* = limit exceeded

100Mbps

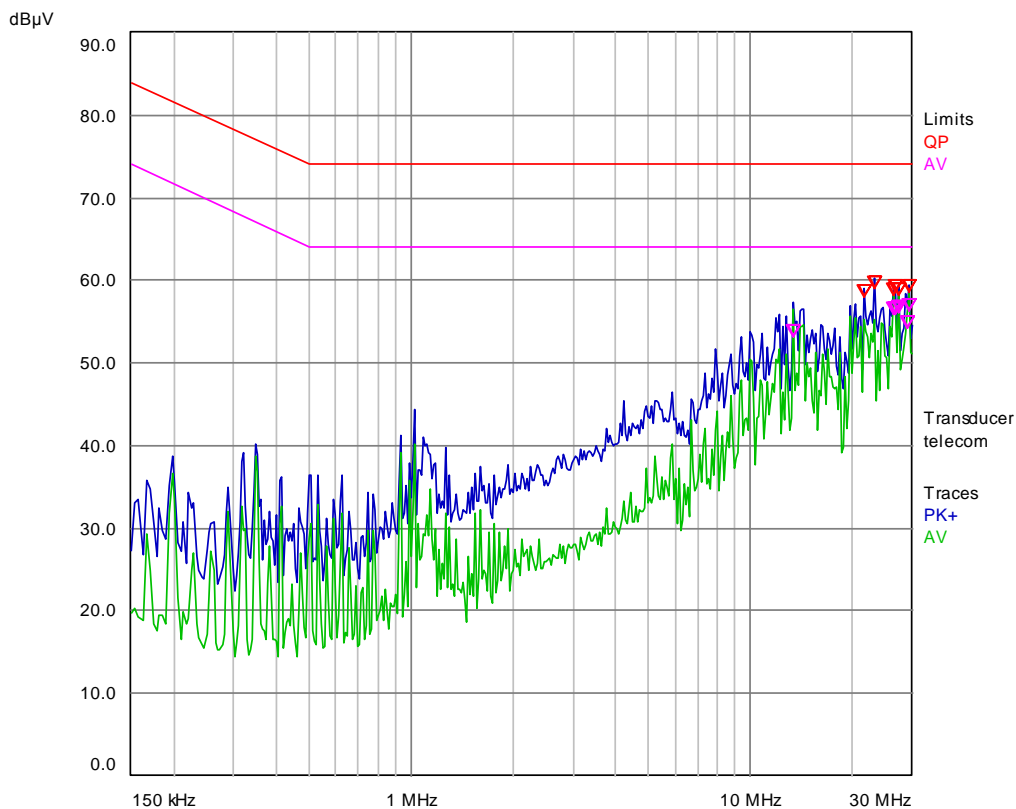

Final Measurement Results

Trace	Frequency (MHz)	Level (dBµV)	Limit (dBµV)	Delta Limit (dB)
2 CA	13.418	53.22	64.00	-10.78
1 QP	21.662	57.91	74.00	-16.09
1 QP	23.126	58.98	74.00	-15.02
1 QP	26.486	58.11	74.00	-15.89
2 CA	26.486	55.91	64.00	-8.09
1 QP	26.61	58.70	74.00	-15.30
2 CA	26.61	55.98	64.00	-8.02
1 QP	27.158	58.11	74.00	-15.89
2 CA	27.158	56.11	64.00	-7.89
2 CA	29.114	54.29	64.00	-9.71
1 QP	29.234	58.53	74.00	-15.47
2 CA	29.234	56.35	64.00	-7.65

* = limit exceeded

1000Mbps

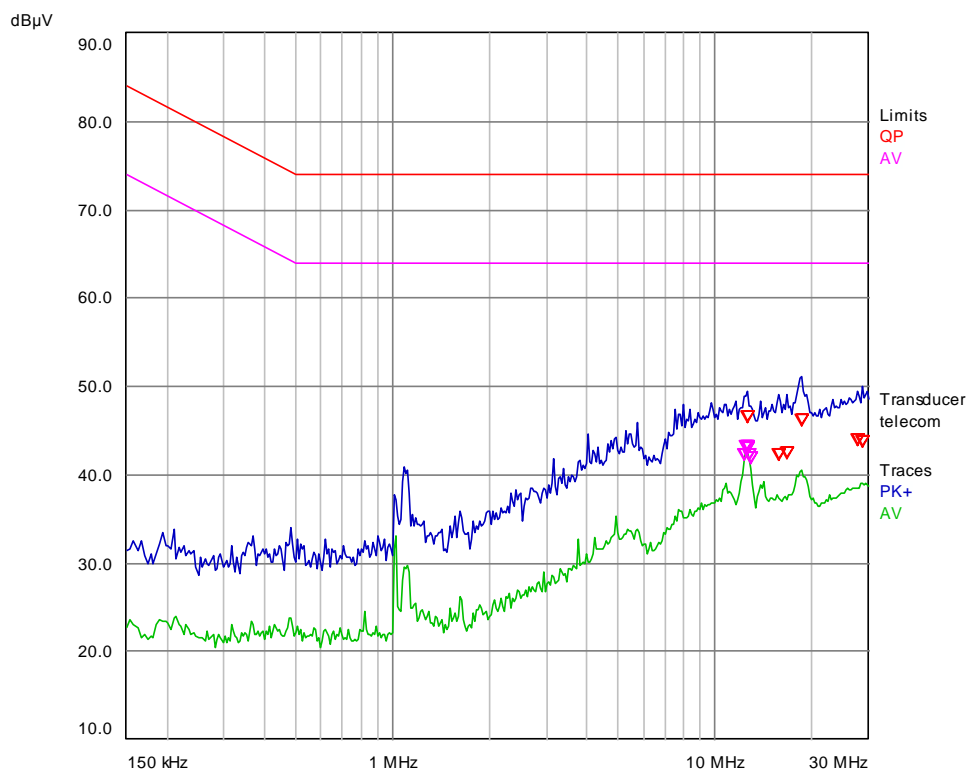

Final Measurement Results

Trace	Frequency (MHz)	Level (dBµV)	Limit (dBµV)	Delta Limit (dB)
2 CA	12.35	41.71	64.00	-22.29
2 CA	12.454	42.52	64.00	-21.48
2 CA	12.554	42.50	64.00	-21.50
1 QP	12.658	45.92	74.00	-28.08
2 CA	12.658	42.41	64.00	-21.59
2 CA	12.758	41.64	64.00	-22.36
2 CA	12.862	41.32	64.00	-22.68
1 QP	15.782	41.71	74.00	-32.29
1 QP	16.746	41.82	74.00	-32.18
1 QP	18.562	45.51	74.00	-28.49
1 QP	27.626	43.23	74.00	-30.77
1 QP	28.754	43.20	74.00	-30.80

* = limit exceeded

Mode b
10Mbps

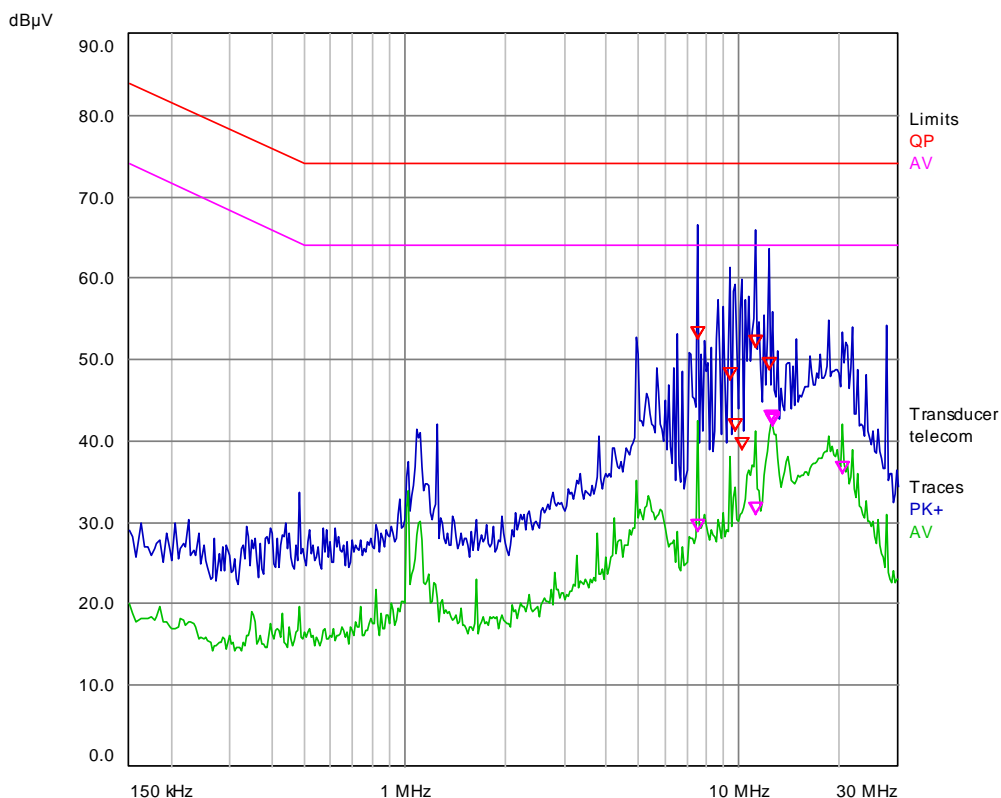

Final Measurement Results

Trace	Frequency (MHz)	Level (dBµV)	Limit (dBµV)	Delta Limit (dB)
1 QP	7.494	52.55	74.00	-21.45
2 CA	7.494	28.80	64.00	-35.20
1 QP	9.35	47.55	74.00	-26.45
1 QP	9.722	41.21	74.00	-32.79
1 QP	10.154	38.89	74.00	-35.11
1 QP	11.194	51.49	74.00	-22.51
2 CA	11.194	30.98	64.00	-33.02
1 QP	12.338	48.85	74.00	-25.15
2 CA	12.454	42.19	64.00	-21.81
2 CA	12.558	41.76	64.00	-22.24
2 CA	12.658	42.06	64.00	-21.94
2 CA	20.382	35.99	64.00	-28.01

* = limit exceeded

100Mbps

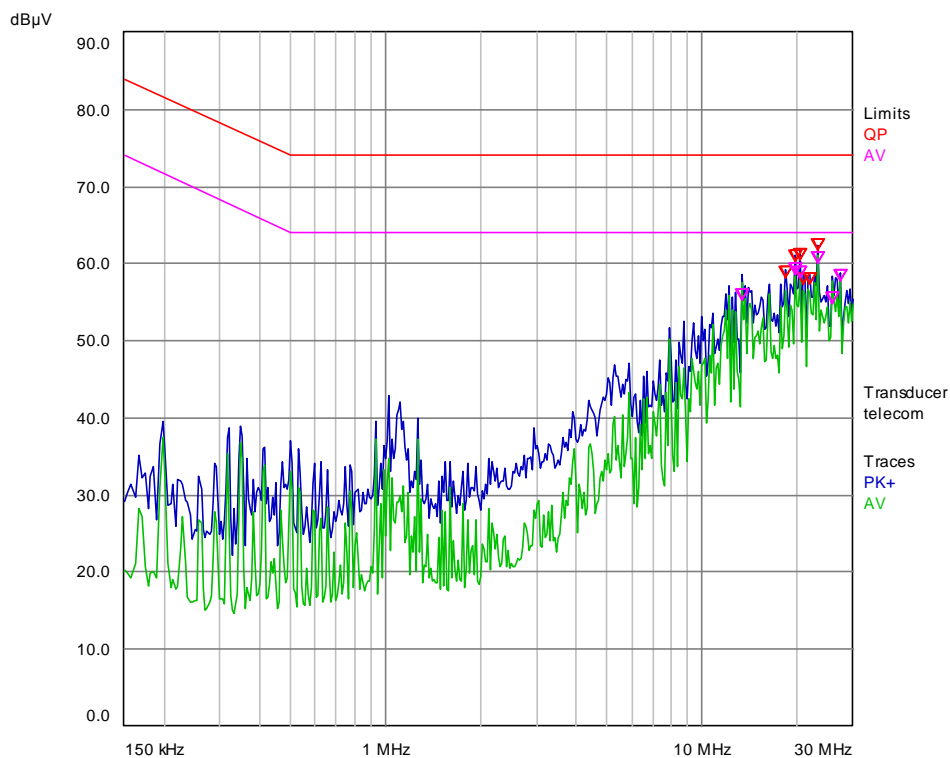

Final Measurement Results

Trace	Frequency (MHz)	Level (dBµV)	Limit (dBµV)	Delta Limit (dB)
2 CA	13.358	55.33	64.00	-8.67
1 QP	18.242	58.12	74.00	-15.88
1 QP	19.71	60.25	74.00	-13.75
2 CA	19.71	58.68	64.00	-5.32
1 QP	20.258	60.47	74.00	-13.53
2 CA	20.258	58.22	64.00	-5.78
1 QP	20.806	57.35	74.00	-16.65
1 QP	21.906	57.40	74.00	-16.60
1 QP	23.13	61.78	74.00	-12.22
2 CA	23.13	59.97	64.00	-4.03
2 CA	25.694	54.86	64.00	-9.14
2 CA	27.158	57.76	64.00	-6.24

* = limit exceeded

1000Mbps

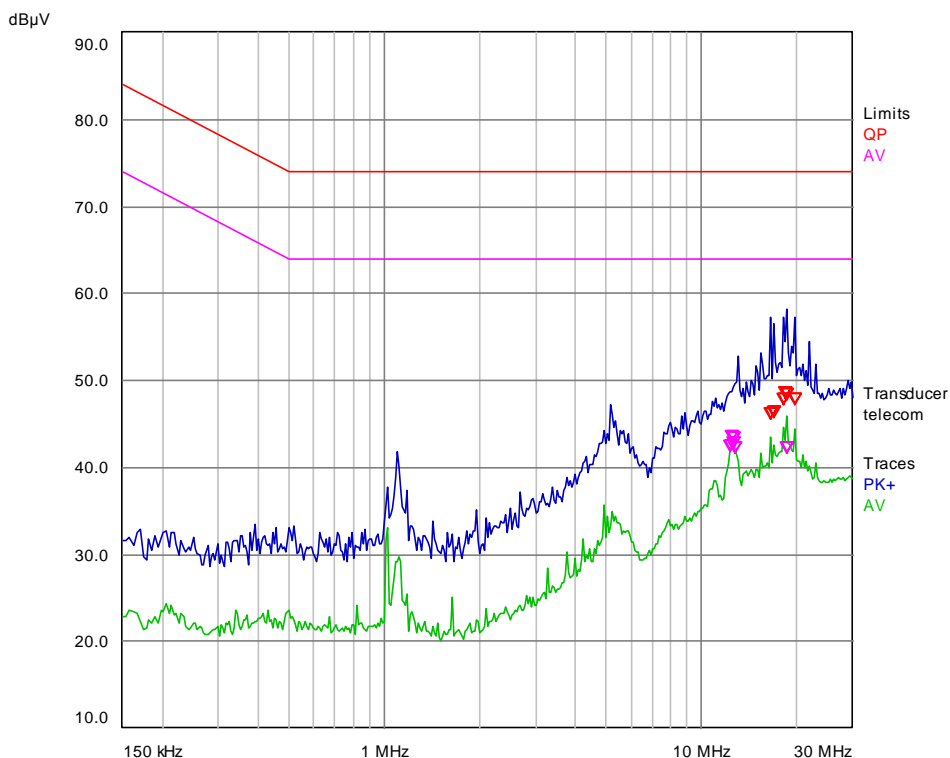

Final Measurement Results

Trace	Frequency (MHz)	Level (dBµV)	Limit (dBµV)	Delta Limit (dB)
2 CA	12.35	41.78	64.00	-22.22
2 CA	12.454	42.96	64.00	-21.04
2 CA	12.554	42.12	64.00	-21.88
2 CA	12.658	42.80	64.00	-21.20
2 CA	12.762	41.56	64.00	-22.44
1 QP	16.418	45.61	74.00	-28.39
1 QP	16.842	45.79	74.00	-28.21
1 QP	18.166	47.18	74.00	-26.82
1 QP	18.43	47.91	74.00	-26.09
1 QP	18.614	47.70	74.00	-26.30
2 CA	18.614	41.64	64.00	-22.36
1 QP	19.698	47.12	74.00	-26.88

* = limit exceeded

6.3 Radiated Emissions (30MHz-1GHz)

Test Requirement: EN 55032:2015
 Test Method: EN 55032:2015
 Frequency Range: 30MHz to 1GHz
 Limit:
 30MHz-230MHz 40 dB(μV/m) quasi-peak
 230MHz-1GHz 47 dB(μV/m) quasi-peak
 Detector: Peak for pre-scan (120kHz resolution bandwidth) 30M to 1000MHz

6.3.1 E.U.T. Operation

Operating Environment:
 Temperature: 23 °C Humidity: 57 % RH Atmospheric Pressure: 1022 mbar
 Test mode:
 a: Typical configuration: Keep EUT monitoring and data running continual, recording video during the test. Powered by power ADS-26FSG-12 12024EPG.
 b: Typical configuration: Keep EUT monitoring and data running continual, recording video during the test. Powered by power MSA-C2000IC12.0-24P-DE

6.3.2 Test Setup Diagram

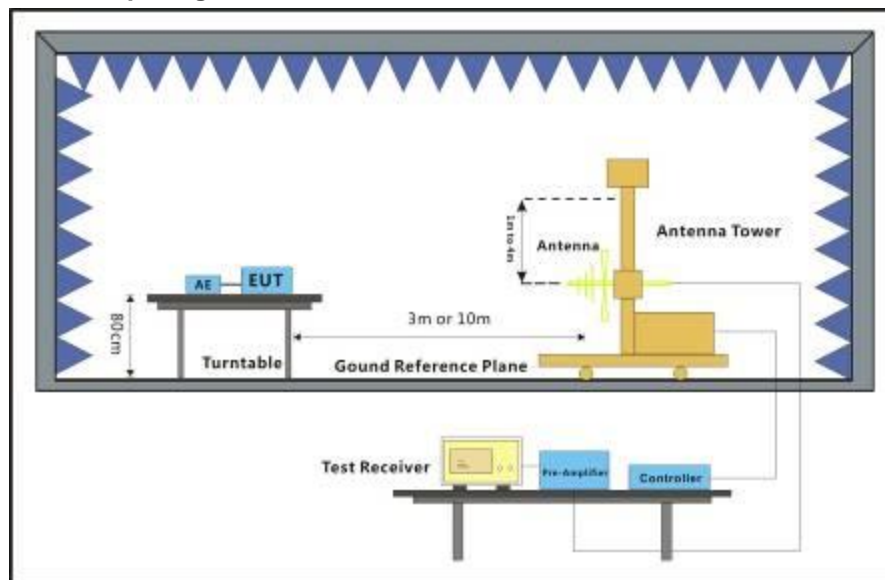

6.3.3 Measurement Data

An initial pre-scan was performed in the chamber using the spectrum analyser in peak detection mode. Quasi-peak measurements were conducted based on the peak sweep graph. The EUT was measured by BiConiLog antenna with 2 orthogonal polarities.

Notes : Emission Level=Read Level + Antenna Factor + Cable Loss – Preamp Factor

Mode:a,

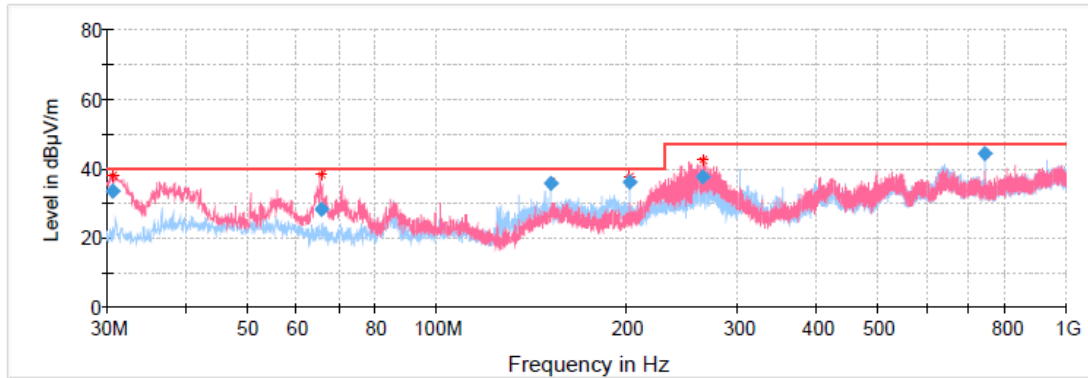

Final Result

Frequency (MHz)	QuasiPeak (dBµV/m)	Limit (dBµV/m)	Margin (dB)	Meas. Time (ms)	Bandwidth (kHz)	Height (cm)	Pol	Azimuth (deg)	Corr. (dB)
30.618500	33.56	40.00	6.44	1000.0	120.000	100.0	V	70.0	11.0
65.645000	28.29	40.00	11.71	1000.0	120.000	107.0	V	138.0	10.8
151.769000	35.86	40.00	4.14	1000.0	120.000	184.0	H	167.0	8.8
202.483000	36.16	40.00	3.84	1000.0	120.000	125.0	H	124.0	12.3
265.085500	37.73	47.00	9.27	1000.0	120.000	161.0	V	177.0	14.1
742.513500	44.34	47.00	2.66	1000.0	120.000	111.0	H	127.0	23.0

Mode b

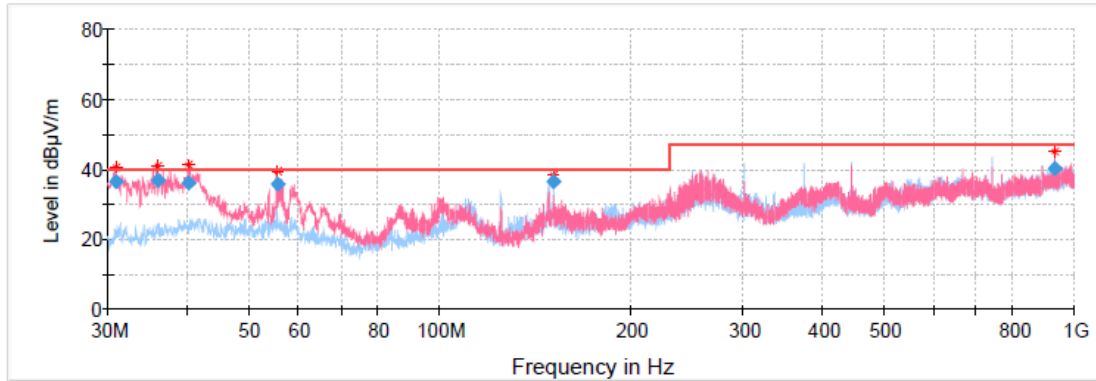

Final Result

Frequency (MHz)	QuasiPeak (dBµV/m)	Limit (dBµV/m)	Margin (dB)	Meas. Time (ms)	Bandwidth (kHz)	Height (cm)	Pol	Azimuth (deg)	Corr. (dB)
30.984500	36.52	40.00	3.48	1000.0	120.000	107.0	V	239.0	11.0
35.983500	37.01	40.00	2.99	1000.0	120.000	107.0	V	5.0	11.6
40.185000	36.21	40.00	3.79	1000.0	120.000	100.0	V	257.0	12.9
55.685500	35.85	40.00	4.15	1000.0	120.000	126.0	V	68.0	12.9
151.073000	36.29	40.00	3.71	1000.0	120.000	209.0	H	171.0	8.7
932.941500	40.24	47.00	6.76	1000.0	120.000	125.0	V	101.0	25.4

6.4 Radiated Emissions (above 1GHz)

Test Requirement:	EN 55032:2015
Test Method:	EN 55032:2015
Frequency Range:	Above 1GHz
Measurement Distance:	3m
Limit:	
1GHz-3GHz	70 dB(μV/m) peak, 50 dB(μV/m) average
3GHz-6GHz	74 dB(μV/m) peak, 54dB(μV/m) average
Detector:	Peak for pre-scan (1000kHz resolution bandwidth) 1000M to 6000MHz

6.4.1 E.U.T. Operation

Operating Environment:

Temperature: 23 °C Humidity: 57 % RH Atmospheric Pressure: 1022 mbar

- Test mode
- a: Typical configuration: Keep EUT monitoring and data running continual, recording video during the test. Powered by power ADS-26FSG-12 12024EPG.
 - b: Typical configuration: Keep EUT monitoring and data running continual, recording video during the test. Powered by power MSA-C2000IC12.0-24P-DE

6.4.2 Test Setup Diagram

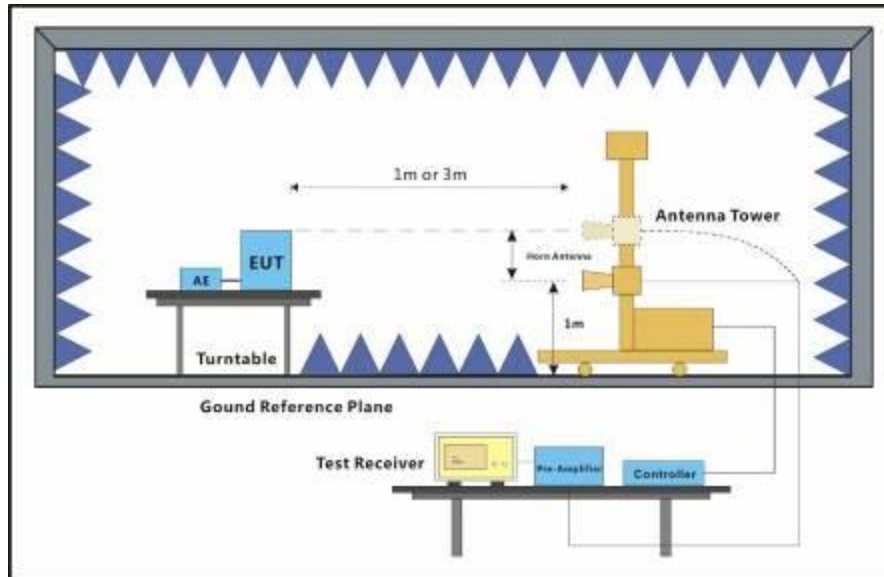

6.4.3 Measurement Data

An initial pre-scan was performed in the chamber using the spectrum analyser in peak detection mode. Quasi-peak measurements were conducted based on the peak sweep graph. The EUT was measured by BiConiLog antenna with 2 orthogonal polarities.

Notes : Emission Level=Read Level + Antenna Factor + Cable Loss – Preamp Factor

Mode:a;

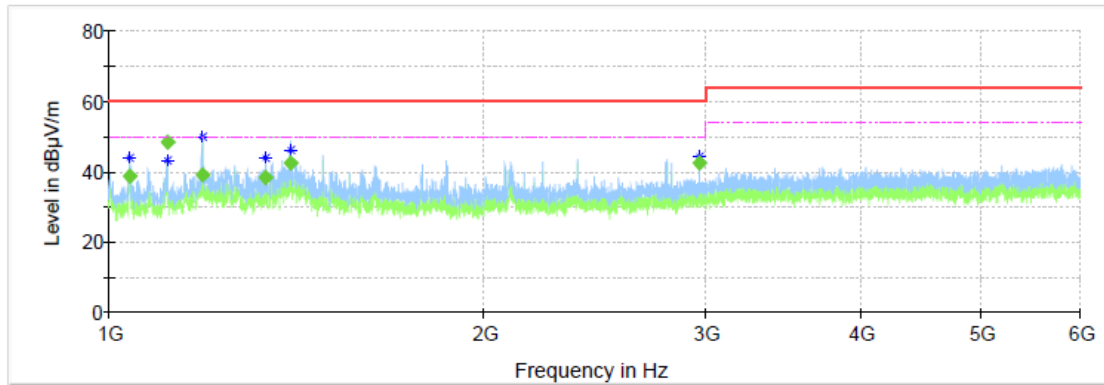

Final Result

Frequency (MHz)	MaxPeak (dBµV/m)	Average (dBµV/m)	Limit (dBµV/m)	Margin (dB)	Meas. Time (ms)	Bandwidth (kHz)	Height (cm)	Pol	Azimuth (deg)	Corr. (dB)
1039.300000	---	38.63	50.00	11.37	1000.0	1000.000	107.0	H	243.0	-18.9
1113.700000	---	48.43	50.00	1.57	1000.0	1000.000	157.0	V	135.0	-18.7
1188.200000	---	38.98	50.00	11.02	1000.0	1000.000	100.0	H	350.0	-18.5
1336.700000	---	38.19	50.00	11.81	1000.0	1000.000	100.0	H	155.0	-16.3
1398.200000	---	42.52	50.00	7.48	1000.0	1000.000	113.0	H	139.0	-15.2
2970.200000	---	42.42	50.00	7.58	1000.0	1000.000	113.0	V	270.0	-10.6

Mode:b

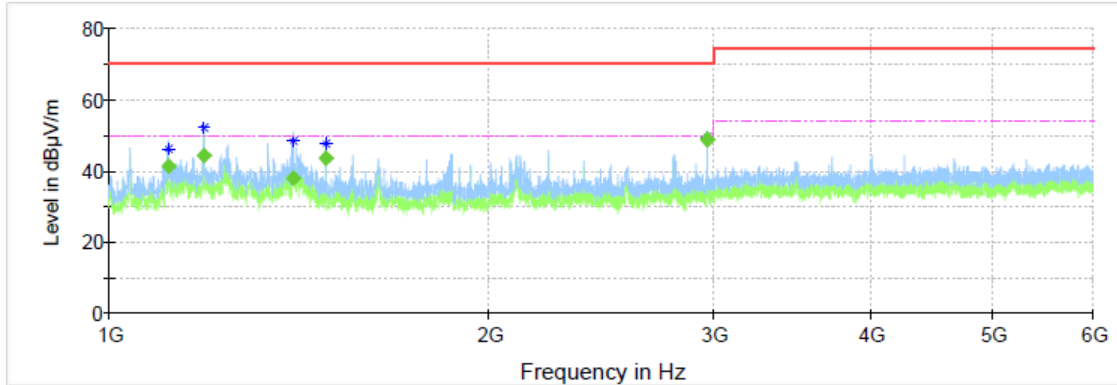

Final Result

Frequency (MHz)	MaxPeak (dBµV/m)	Average (dBµV/m)	Limit (dBµV/m)	Margin (dB)	Meas. Time (ms)	Bandwidth (kHz)	Height (cm)	Pol	Azimuth (deg)	Corr. (dB)
1113.800000	---	41.28	50.00	8.72	1000.0	1000.000	202.0	V	-1.0	-18.7
1188.200000	---	44.10	50.00	5.90	1000.0	1000.000	100.0	V	159.0	-18.5
1397.800000	---	38.01	50.00	11.99	1000.0	1000.000	113.0	H	139.0	-15.2
1485.200000	---	43.43	50.00	6.57	1000.0	1000.000	100.0	H	300.0	-15.8
2970.200000	---	48.58	50.00	1.42	1000.0	1000.000	131.0	V	8.0	-10.6
2970.400000	---	48.38	50.00	1.62	1000.0	1000.000	131.0	V	8.0	-10.6

6.5 Harmonic Current Emission

Test Requirement: EN 61000-3-2:2014
Test Method: EN 61000-3-2:2014
Frequency Range: 100Hz to 2kHz

6.5.1 Measurement Data

There is no need for Harmonics test to be performed on this product (rated power is less than 75W) in accordance with EN 61000-3-2:2014.

For further details, please refer to Clause 7 of EN 61000-3-2 which states:

"For the following categories of equipment, limits are not specified in this standard.- equipment with a rated power of 75W or less, other than lighting equipment."

6.6 Voltage Fluctuations and Flicker

Test Requirement: EN 61000-3-3:2013

Test Method: EN 61000-3-3:2013

6.6.1 E.U.T. Operation

Operating Environment:

Temperature: 23 °C Humidity: 55 % RH Atmospheric Pressure: 1019 mbar

Test mode: a: Typical configuration: Keep EUT monitoring and data running continual, recording video during the test. Powered by power ADS-26FSG-12 12024EPG.

b: Typical configuration: Keep EUT monitoring and data running continual, recording video during the test. Powered by power MSA-C2000IC12.0-24P-DE

6.6.2 Test Setup Diagram

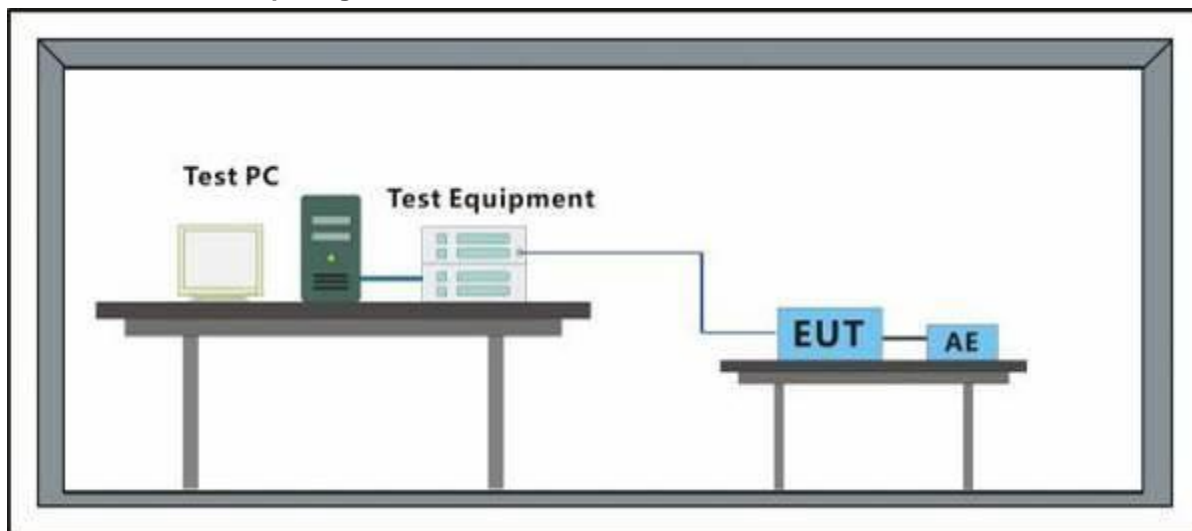

6.6.3 Measurement Data

Mode:a

Parameter values recorded during the test:

Vrms at the end of test (Volt):	229.76			
Highest dt (%):	0.00	Test limit (%):	N/A	N/A
T-max (mS):	0	Test limit (mS):	500.0	Pass
Highest dc (%):	0.00	Test limit (%):	3.30	Pass
Highest dmax (%):	-0.03	Test limit (%):	4.00	Pass
Highest Pst (10 min. period):	0.261	Test limit:	1.000	Pass
Highest Plt (2 hr. period):	0.114	Test limit:	0.650	Pass

Mode b

Parameter values recorded during the test:

Vrms at the end of test (Volt):	229.78			
Highest dt (%):	0.00	Test limit (%):	N/A	N/A
T-max (mS):	0	Test limit (mS):	500.0	Pass
Highest dc (%):	0.00	Test limit (%):	3.30	Pass
Highest dmax (%):	-0.04	Test limit (%):	4.00	Pass
Highest Pst (10 min. period):	0.271	Test limit:	1.000	Pass
Highest Plt (2 hr. period):	0.119	Test limit:	0.650	Pass



SGS-CSTC Standards Technical Services (Shanghai) Co., Ltd.

Report No.: SHEM190601386701
Page: 32 of 68

7 Immunity Test Results

7.1 Performance Criteria Description in EN 50130-4:2011 +A1:2014

There shall be no damage, malfunction or change of status due to the conditioning. Flickering of an indicator during the application of the discharges is permissible, providing that there is no residual change in the EUT or any change in outputs, which could be interpreted by associated equipment as a change.

For further details, please refer to Clause 7.4, 8.4, 9.4, 10.4, 11.4, 12.4 and 13.4, of EN 50130-4.

7.2 Electrostatic Discharge

Test Requirement: EN 50130-4:2011 +A1:2014
 Test Method: EN 61000-4-2:2009
 Number of Discharge: Minimum 10 times at each test point for Air Discharge
 Minimum 50 times at each test point for Contact or VCP & HCP Discharge
 Discharge Mode: Single Discharge
 Discharge Period: 1 second minimum

7.2.1 Test Setup Diagram

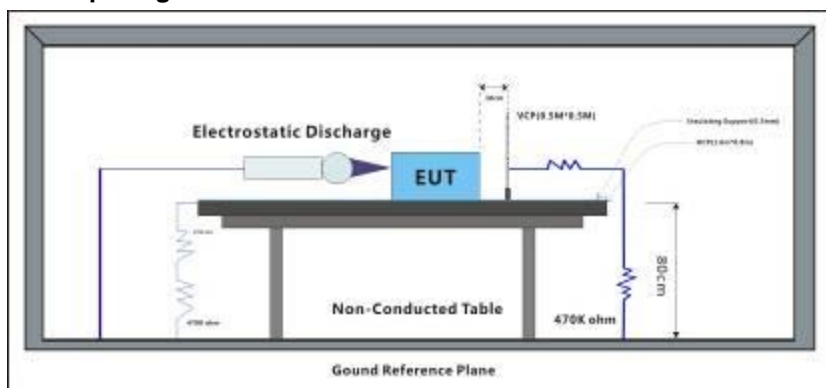

7.2.2 E.U.T. Operation

Operating Environment:
 Temperature: 19.8 °C Humidity: 58 % RH Atmospheric Pressure: 1022.2 mbar
 Test mode:
 a: Typical configuration: Keep EUT monitoring and data running continual, recording video during the test. Powered by power ADS-26FSG-12 12024EPG.
 b: Typical configuration: Keep EUT monitoring and data running continual, recording video during the test. Powered by power MSA-C2000IC12.0-24P-DE

7.2.3 Test Results:

Observations: Test Point:
 1. All insulated enclosure and seams.
 2. All accessible metal parts of the enclosure.
 3. All side

Discharge type	Level (kV)	Polarity	Test Point	Result / Observations
Air Discharge	2,4,8	+	1	Pass
Air Discharge	2,4,8	-	1	Pass
Contact Discharge	6	+	2	Pass
Contact Discharge	6	-	2	Pass
Horizontal Coupling	6	+	3	Pass
Horizontal Coupling	6	-	3	Pass
Vertical Coupling	6	+	3	Pass
Vertical Coupling	6	-	3	Pass

Results:

- The EUT working normal, before the conditioning.
- Monitor the EUT during the conditioning period there was no status change has occurred, during the conditioning.



SGS-CSTC Standards Technical Services (Shanghai) Co., Ltd.

Report No.: SHEM190601386701
Page: 35 of 68

3. No degradation in the performance of the EUT was observed, after the conditioning.

7.3 Electrical Fast Transients/Burst at Power Port

Test Requirement: EN 50130-4:2011 +A1:2014
 Test Method: EN 61000-4-4:2012
 Repetition Frequency: 100kHz
 Burst Period: 300ms
 Test Duration: 1 minute per level & polarity

7.3.1 Test Setup Diagram

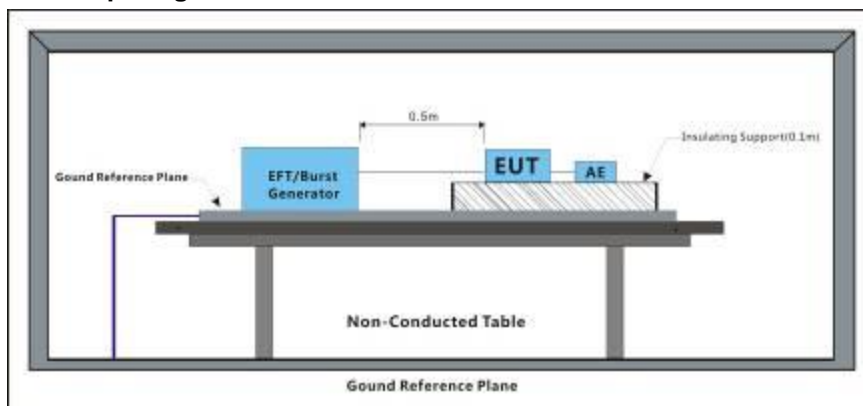

7.3.2 E.U.T. Operation

Operating Environment:

Temperature: 24 °C Humidity: 58 % RH Atmospheric Pressure: 1022.2 mbar

Test mode:
 a: Typical configuration: Keep EUT monitoring and data running continual, recording video during the test. Powered by power ADS-26FSG-12 12024EPG.
 b: Typical configuration: Keep EUT monitoring and data running continual, recording video during the test. Powered by power MSA-C2000IC12.0-24P-DE

7.3.3 Test Results:

Test Line	Level (kV)	Polarity	CDN/Clamp	Result / Observations
AC power port	2	+	CDN	Pass
AC power port	2	-	CDN	Pass

Results:

1. The EUT working normal, before the conditioning.
2. Monitor the EUT during the conditioning period there was no status change has occurred, during the conditioning.
3. No degradation in the performance of the EUT was observed, after the conditioning.

7.4 Electrical Fast Transients/Burst at Signal Port

Test Requirement: EN 50130-4:2011 +A1:2014
 Test Method: EN 61000-4-4:2012
 Repetition Frequency: 100kHz
 Burst Period: 300ms
 Test Duration: 1 minute per level & polarity

7.4.1 Test Setup Diagram

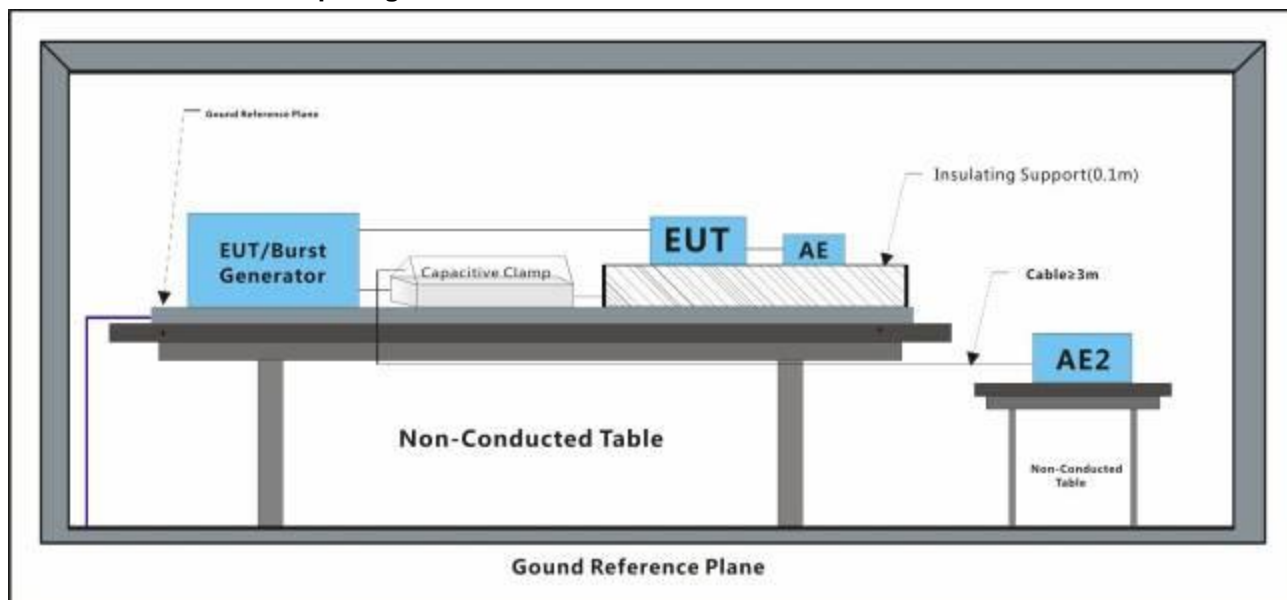

7.4.2 E.U.T. Operation

Operating Environment:

Temperature: 24 °C Humidity: 58 % RH Atmospheric Pressure: 1022.2 mbar

Test mode:
 a: Typical configuration: Keep EUT monitoring and data running continual, recording video during the test. Powered by power ADS-26FSG-12 12024EPG.
 b: Typical configuration: Keep EUT monitoring and data running continual, recording video during the test. Powered by power MSA-C2000IC12.0-24P-DE

7.4.3 Test Results:

Port	Level (kV)	Polarity	CDN/Clamp	Result / Observations
Signal port	1	+	Clamp	Pass
Signal port	1	-	Clamp	Pass

Results:

1. The EUT working normal, before the conditioning.
2. Monitor the EUT during the conditioning period there was no status change has occurred, during the conditioning.
3. No degradation in the performance of the EUT was observed, after the conditioning.

7.5 Surge at Power Port

Test Requirement: EN 50130-4:2011 +A1:2014
 Test Method: EN 61000-4-5:2014
 Interval: 60s between each surge
 No. of surges: 5 positive, 5 negative

7.5.1 Test Setup Diagram

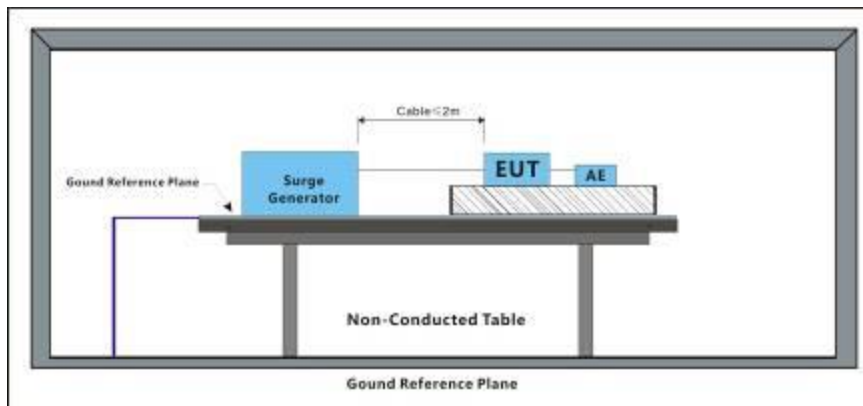

7.5.2 E.U.T. Operation

Operating Environment:
 Temperature: 23 °C Humidity: 56 % RH Atmospheric Pressure: 1022.2 mbar
 Test mode:
 a: Typical configuration: Keep EUT monitoring and data running continual, recording video during the test. Powered by power ADS-26FSG-12 12024EPG.
 b: Typical configuration: Keep EUT monitoring and data running continual, recording video during the test. Powered by power MSA-C2000IC12.0-24P-DE

7.5.3 Test Results:

Test Line	Level (kV)	Polarity	Phase (deg)	Result / Observations
L-N	0.5,1	+	0°	Pass
L-N	0.5,1	-	0°	Pass
L-N	0.5,1	+	90°	Pass
L-N	0.5,1	-	90°	Pass
L-N	0.5,1	+	180°	Pass
L-N	0.5,1	-	180°	Pass
L-N	0.5,1	+	270°	Pass
L-N	0.5,1	-	270°	Pass
L-PE	0.5,1,2	+	0°	Pass
L-PE	0.5,1,2	-	0°	Pass
L-PE	0.5,1,2	+	90°	Pass
L-PE	0.5,1,2	-	90°	Pass
L-PE	0.5,1,2	+	180°	Pass
L-PE	0.5,1,2	-	180°	Pass
L-PE	0.5,1,2	+	270°	Pass
L-PE	0.5,1,2	-	270°	Pass

N-PE	0.5,1,2	+	0°	Pass
N-PE	0.5,1,2	-	0°	Pass
N-PE	0.5,1,2	+	90°	Pass
N-PE	0.5,1,2	-	90°	Pass
N-PE	0.5,1,2	+	180°	Pass
N-PE	0.5,1,2	-	180°	Pass
N-PE	0.5,1,2	+	270°	Pass
N-PE	0.5,1,2	-	270°	Pass

Results:

1. The EUT working normal, before the conditioning.
2. Monitor the EUT during the conditioning period there was no status change has occurred, during the conditioning.
3. No degradation in the performance of the EUT was observed, after the conditioning.

7.6 Surge at Signal Port

Test Requirement: EN 50130-4:2011 +A1:2014

Test Method: EN 61000-4-5:2014

7.6.1 Test Setup Diagram

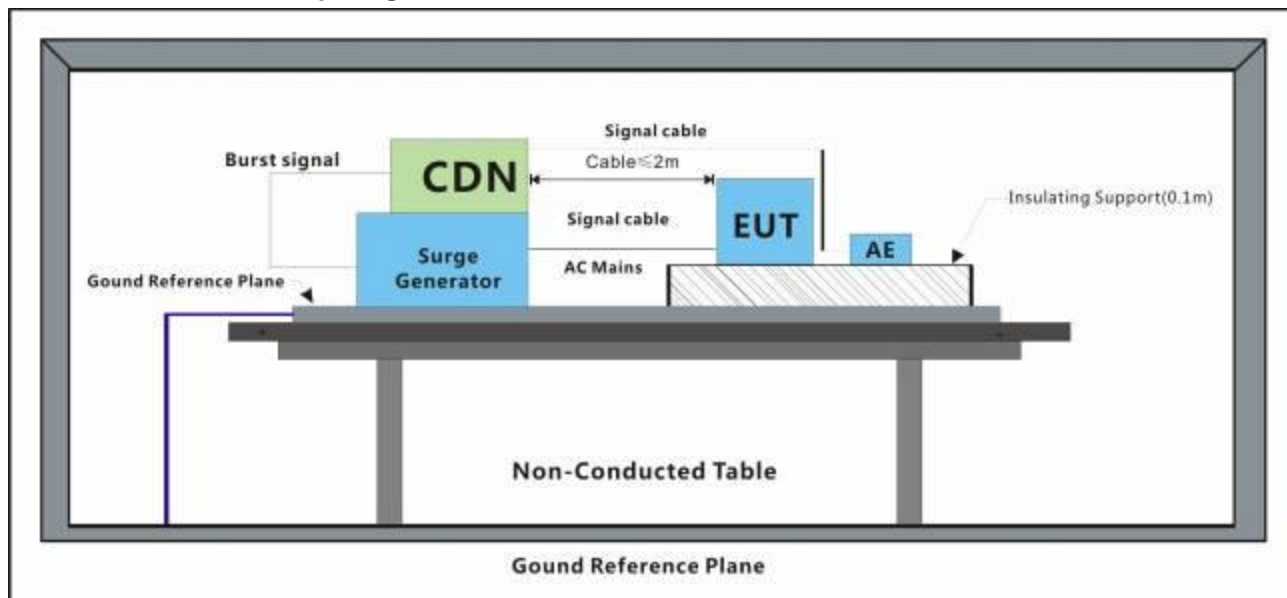

7.6.2 E.U.T. Operation

Operating Environment:

Temperature: 23 °C Humidity: 56 % RH Atmospheric Pressure: 1022.2 mbar

Test mode: a: Typical configuration: Keep EUT monitoring and data running continual, recording video during the test. Powered by power ADS-26FSG-12 12024EPG.
b: Typical configuration: Keep EUT monitoring and data running continual, recording video during the test. Powered by power MSA-C2000IC12.0-24P-DE

7.6.3 Test Results:

Port	Line	Level (kV)	Polarity	Result / Observations
Signal port	Line-Ground	0.5	+	Pass
Signal port	Line-Ground	0.5	-	Pass
Signal port	Line-Ground	1	+	Pass
Signal port	Line-Ground	1	-	Pass

Results:

1. The EUT working normal, before the conditioning.
2. Monitor the EUT during the conditioning period there was no status change has occurred, during the conditioning.
3. No degradation in the performance of the EUT was observed, after the conditioning.

7.7 Voltage Dips and Interruptions

Test Requirement: EN 50130-4:2011 +A1:2014
 Test Method: EN 61000-4-11:2004
 Performance Criterion: 0% of UT (Supply Voltage) for 250 Periods; 40% of UT for 10 Periods; 70% of UT for 25 Periods; 80% of UT for 250 Periods;
 No. of Dips / Interruptions: 3 per Level
 Time between dropout 10s

7.7.1 Test Setup Diagram

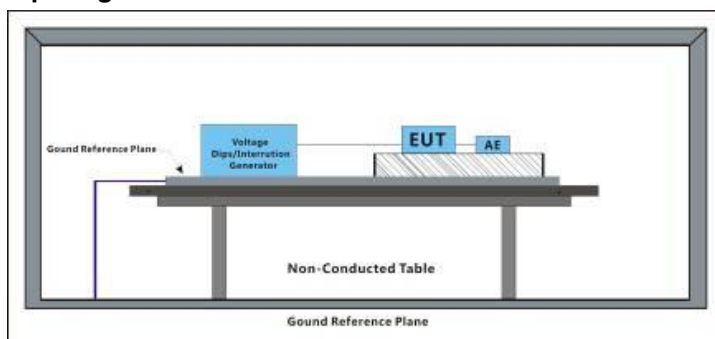

7.7.2 E.U.T. Operation

Operating Environment:
 Temperature: 24 °C Humidity: 58 % RH Atmospheric Pressure: 1012.5 mbar
 Test mode:
 a: Typical configuration: Keep EUT monitoring and data running continual, recording video during the test. Powered by power ADS-26FSG-12 12024EPG.
 b: Typical configuration: Keep EUT monitoring and data running continual, recording video during the test. Powered by power MSA-C2000IC12.0-24P-DE

7.7.3 Test Results:

Level % UT	Phase (deg)	Duration	No. of Dips / Interruptions	Result / Observations
80	0°	250 Cycles	3	Pass
80	180°	250 Cycles	3	Pass
70	0°	25 Cycles	3	Pass
70	180°	25 Cycles	3	Pass
40	0°	10 Cycles	3	Pass
40	180°	10 Cycles	3	Pass
0	0°	250 Cycles	3	Pass
0	180°	250 Cycles	3	Pass

Results:

- The EUT working normal, before the conditioning.
- Monitor the EUT during the conditioning period :
 80%UT Lasts for 250 cycles: During the test, No degradation in the performance of the EUT was observed
 70%UT Lasts for 25 cycles: During the test, No degradation in the performance of the EUT was observed
 40%UT Lasts for 10 cycles: During the test, No degradation in the performance of the EUT was observed
 0%UT Lasts for 250 cycles: During the test , the Sample restart, after the test , all the functions recovery automatically



3. No degradation in the performance of the EUT was observed, after the conditioning.

7.8 Mains Supply Voltage Variations-Conditioning

Test Requirement: EN 50130-4:2011 +A1:2014
 Test Method: EN 50130-4:2011+A1:2014
 Voltage max.: AC 264V (U_{max} : $U_{nom} + 10\%$)
 Voltage min.: AC 85V (U_{min} : $U_{nom} - 15\%$)
 Unom Voltage: AC 230V

7.8.1 Test Setup Diagram

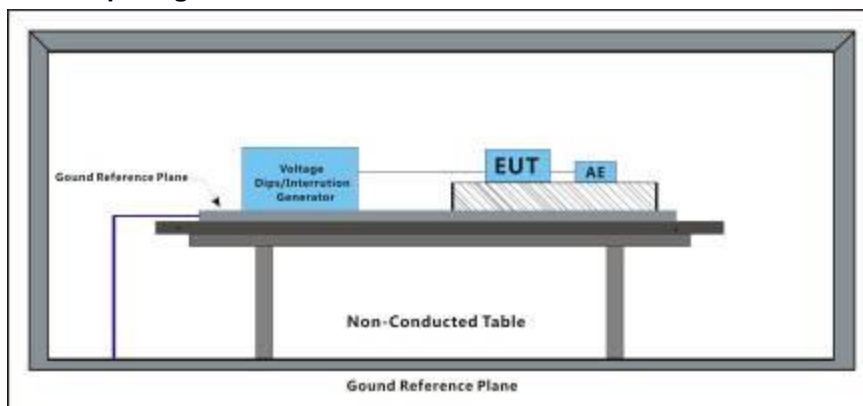

7.8.2 E.U.T. Operation

Operating Environment:

Temperature: 25 °C Humidity: 58 % RH Atmospheric Pressure: 1012.5 mbar

Test mode:
 a: Typical configuration: Keep EUT monitoring and data running continual, recording video during the test. Powered by power ADS-26FSG-12 12024EPG.
 b: Typical configuration: Keep EUT monitoring and data running continual, recording video during the test. Powered by power MSA-C2000IC12.0-24P-DE

7.8.3 Test Results: Pass

Test phenomenon description for the EUT:

1. The EUT working normal, before the conditioning.
2. Monitor the EUT during the conditioning period and detected no any changes in states, during the conditioning.
3. No degradation in the performance of the EUT was observed, after the conditioning.

7.9 Radiated Immunity(80MHz-2.7GHz)

Test Requirement: EN 50130-4:2011 +A1:2014
 Test Method: EN 61000-4-3:2006 +A1:2008+A2:2010
 Modulation: 80%, 1 kHz Amplitude Modulation & 0.5s ON 0.5s OFF Pulse Modulation

7.9.1 Test Setup Diagram

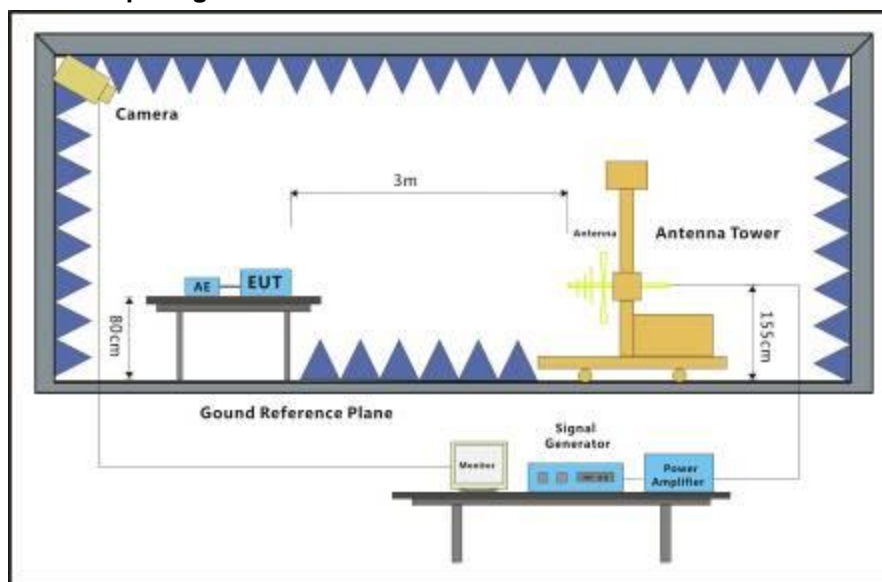

7.9.2 E.U.T. Operation

Operating Environment:
 Temperature: 21.3 °C Humidity: 49 % RH Atmospheric Pressure: 1020.2 mbar
 Test mode:
 a: Typical configuration: Keep EUT monitoring and data running continual, recording video during the test. Powered by power ADS-26FSG-12 12024EPG.
 b: Typical configuration: Keep EUT monitoring and data running continual, recording video during the test. Powered by power MSA-C2000IC12.0-24P-DE

7.9.3 Test Results:

Frequency	Level (V/m)	EUT Face	Dwell time	Result / Observations
80MHz-2.7GHz	10	Front/ Back/ Left/ Right/ Top/ Underside	3s	Pass
80MHz-2.7GHz	3	Front/ Back/ Left/ Right/ Top/ Underside	3s	Pass
80MHz-2.7GHz	1	Front/ Back/ Left/ Right/ Top/ Underside	3s	Pass

Results:

- The EUT working normal, before the conditioning.
- Monitor the EUT during the conditioning period:
 - 10V/M: During the test, No degradation in the performance of the EUT was observed
 - 3V/M: During the test, No degradation in the performance of the EUT was observed
 - 1V/M: During the test, No degradation in the performance of the EUT was observed
- No degradation in the performance of the EUT was observed, after the conditioning.

7.10 Conducted Immunity at Power Port (150kHz-100MHz)

Test Requirement: EN 50130-4:2011 +A1:2014
 Test Method: EN 61000-4-6:2014
 Modulation: 80%, 1 kHz Amplitude Modulation & 0.5s ON 0.5s OFF Pulse Modulation

7.10.1 Test Setup Diagram

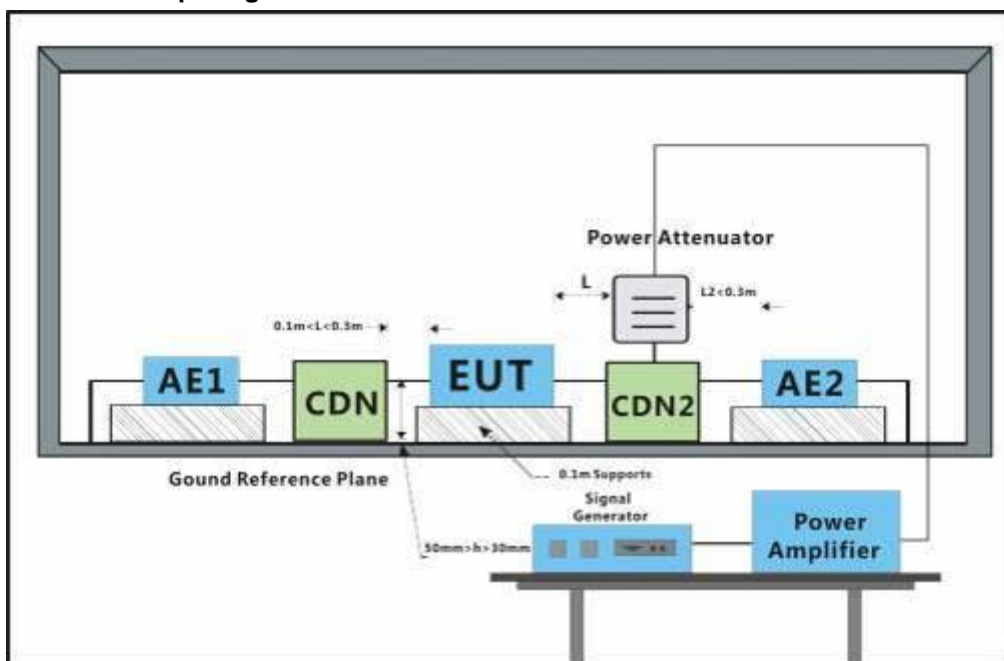

7.10.2 E.U.T. Operation

Operating Environment:
 Temperature: 21.4 °C Humidity: 47 % RH Atmospheric Pressure: 1021.2 mbar
 Test mode:
 a: Typical configuration: Keep EUT monitoring and data running continual, recording video during the test. Powered by power ADS-26FSG-12 12024EPG.
 b: Typical configuration: Keep EUT monitoring and data running continual, recording video during the test. Powered by power MSA-C2000IC12.0-24P-DE

7.10.3 Test Results:

Cable port	Level (Vrms)	CDN/Clamp	Dwell time	Result / Observations
AC power port	10	CDN	3s	Pass
AC power port	3	CDN	3s	Pass
AC power port	1	CDN	3s	Pass

Results:

- The EUT working normal, before the conditioning.
- Monitor the EUT during the conditioning period:
 - 10V: During the test, no degradation in the performance of the EUT was observed.
 - 3V: During the test, no degradation in the performance of the EUT was observed.
 - 1V: During the test, no degradation in the performance of the EUT was observed.
- No degradation in the performance of the EUT was observed, after the conditioning.

7.11 Conducted Immunity at Signal Port (150kHz-100MHz)

Test Requirement: EN 50130-4:2011 +A1:2014
 Test Method: EN 61000-4-6:2014
 Modulation: 80%, 1 kHz Amplitude Modulation & 0.5s ON 0.5s OFF Pulse Modulation

7.11.1 Test Setup Diagram

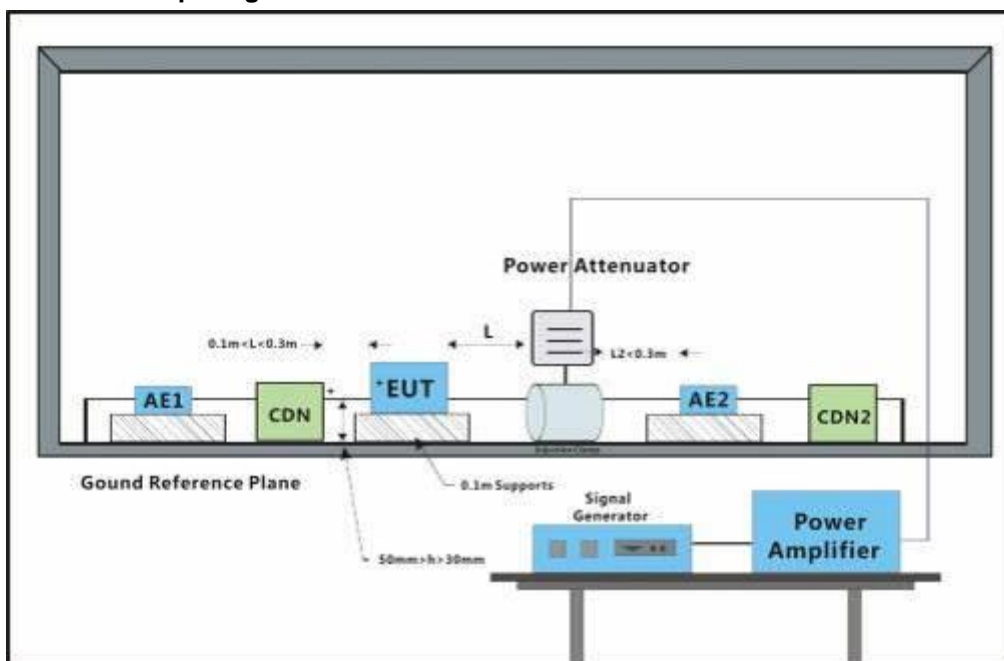

7.11.2 E.U.T. Operation

Operating Environment:
 Temperature: 21.4 °C Humidity: 47 % RH Atmospheric Pressure: 1021.2 mbar
 Test mode:
 a: Typical configuration: Keep EUT monitoring and data running continual, recording video during the test. Powered by power ADS-26FSG-12 12024EPG.
 b: Typical configuration: Keep EUT monitoring and data running continual, recording video during the test. Powered by power MSA-C2000IC12.0-24P-DE

7.11.3 Test Results:

Port	Level (Vrms)	CDN/Clamp	Dwell time	Result / Observations
Signal port	10	Clamp	3s	Pass ¹⁾
Signal port	3	Clamp	3s	Pass ²⁾
Signal port	1	Clamp	3s	Pass*

Results:

1. The EUT working normal, before the conditioning.

2. Monitor the EUT during the conditioning period:

TVI Video in:

10V: Water ripples were observed on the TVI preview in the frequency band of and 1M~15MHz. Color stripe was observed on the TVI preview in the frequency band of 40M~54MHz.

3V: Slight Water ripples were observed on the TVI preview in the frequency band of and 1M~25MHz. Slight color stripe was observed on the TVI preview in the frequency band of 45M~60MHz.

1V: During the test, no degradation in the performance of the EUT was observed.

CVBS Video out:

10V: Water ripples were observed on the TVI preview in the frequency band of and 5M~35MHz. Color stripe was observed on the TVI preview in the frequency band of 39M~54MHz.

3V: Slight Water ripples were observed on the TVI preview in the frequency band of and 5M~40MHz. Slight color stripe was observed on the TVI preview in the frequency band of 39M~47MHz.

1V: During the test, no degradation in the performance of the EUT was observed.

3. No degradation in the performance of the EUT was observed, after the conditioning.

8 Photographs

8.1 Conducted Emissions at Mains Terminals (150kHz-30MHz) Test Setup



8.2 Asymmetric Mode Conducted Emissions (150kHz-30MHz) Test Setup



8.3 Radiated Emissions (30MHz-1GHz) Test Setup

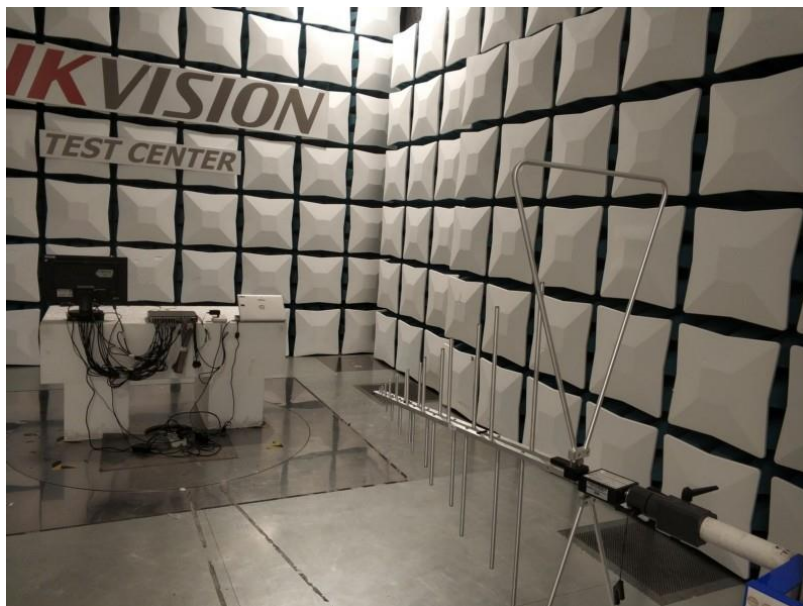

8.4 Radiated Emissions (above 1GHz) Test Setup

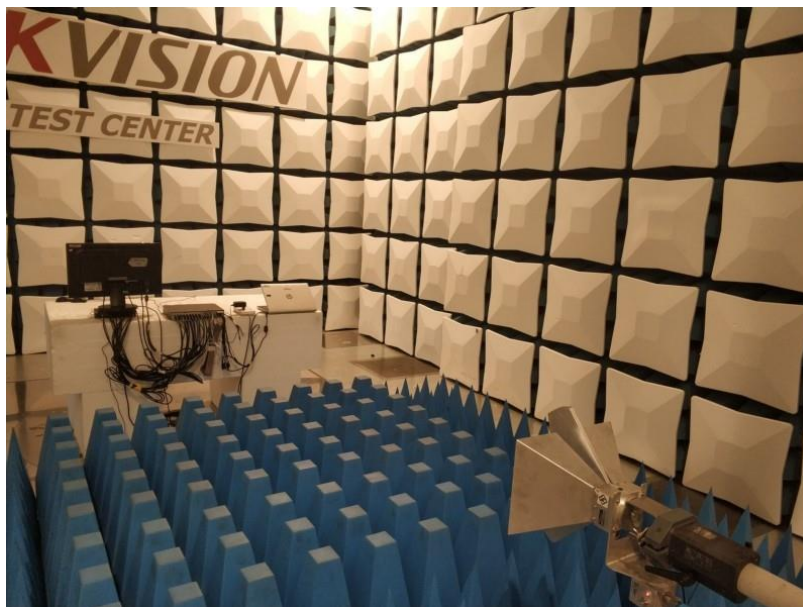

8.5 Voltage Fluctuations and Flicker Test Setup



8.6 Electrostatic Discharge Test Setup



8.7 Radiated Immunity (80MHz-2.7GHz) Test Setup



8.8 Electrical Fast Transients/Burst at Power Port Test Setup



8.9 Electrical Fast Transients/Burst at Signal Port Test Setup



8.10 Surge at Power Port Test Setup



8.11 Surge at Signal Port Test Setup

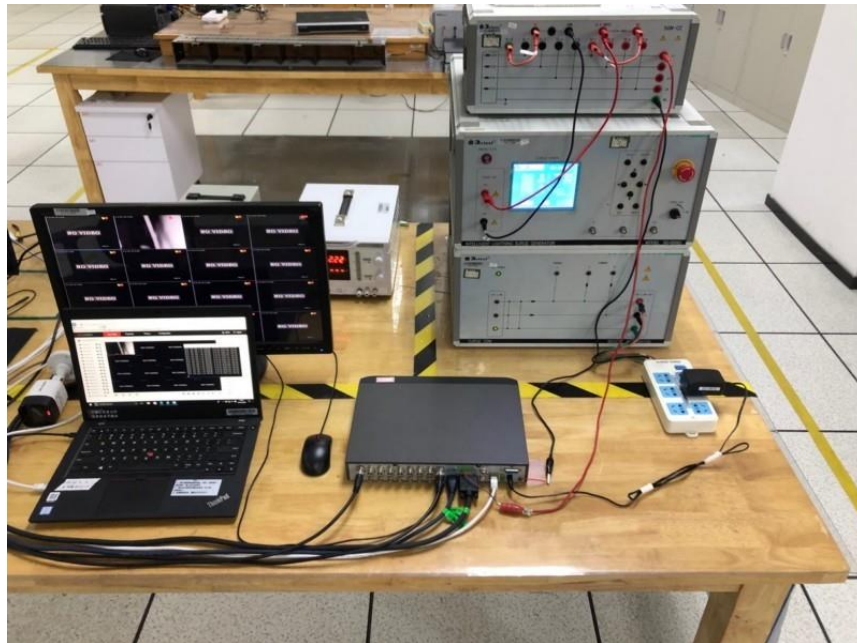
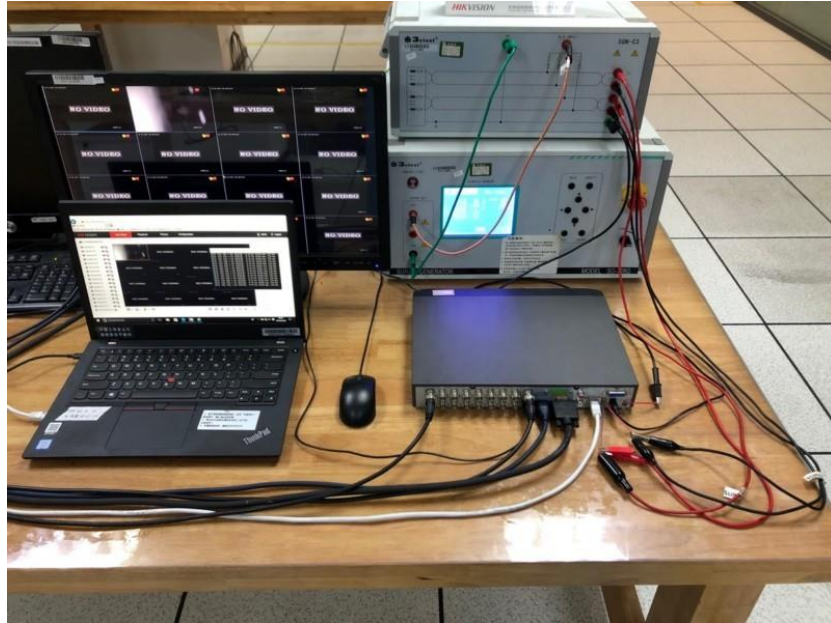

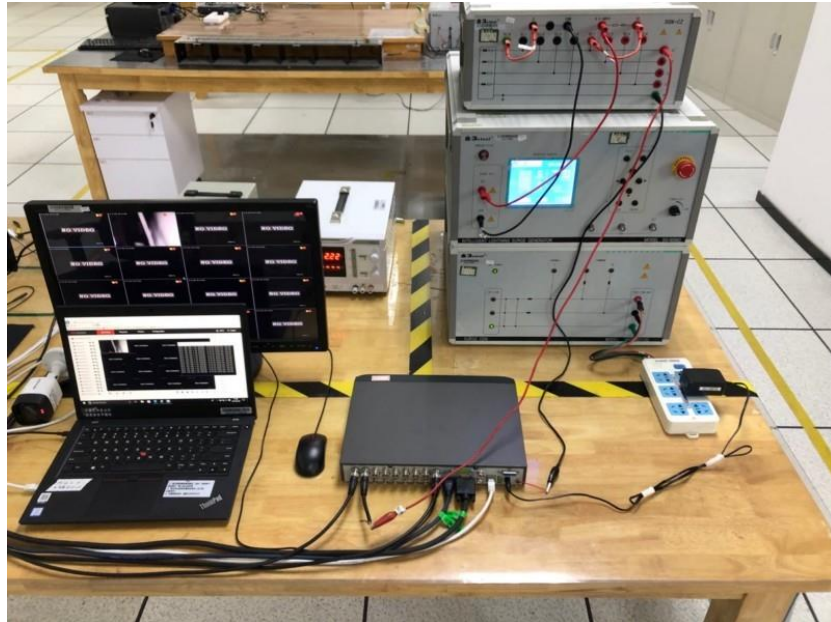
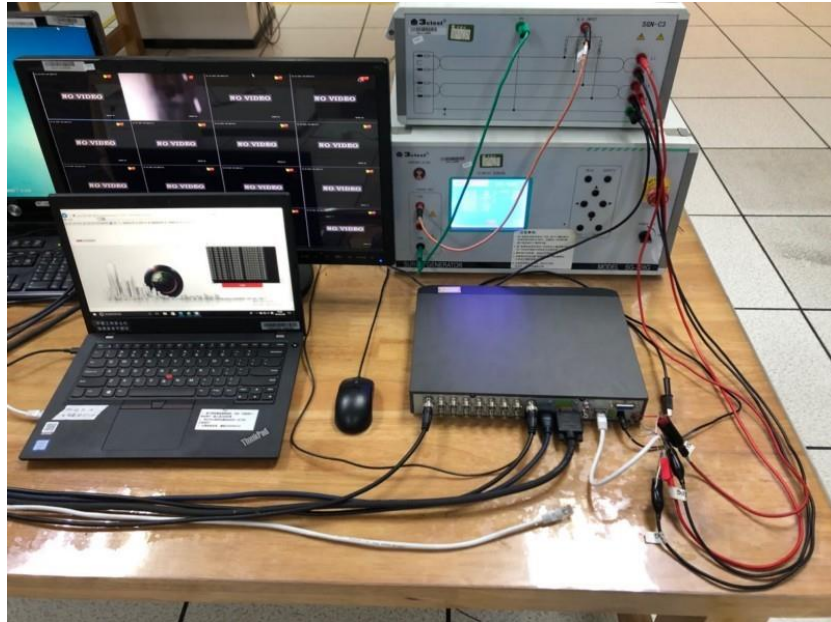

8.12 Conducted Immunity at Power Port (150kHz-100MHz) Test Setup



8.13 Conducted Immunity at Signal Port (150kHz-100MHz) Test Setup

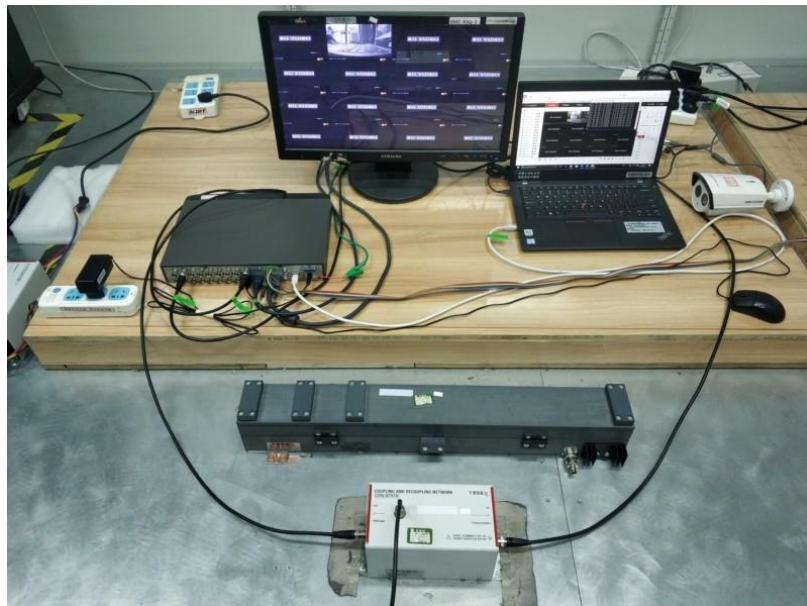

8.14 Voltage Dips and Interruptions Test Setup



8.15 Mains Supply Voltage Variations-Conditioning Test Setup



8.16 EUT Constructional Details (EUT Photos)



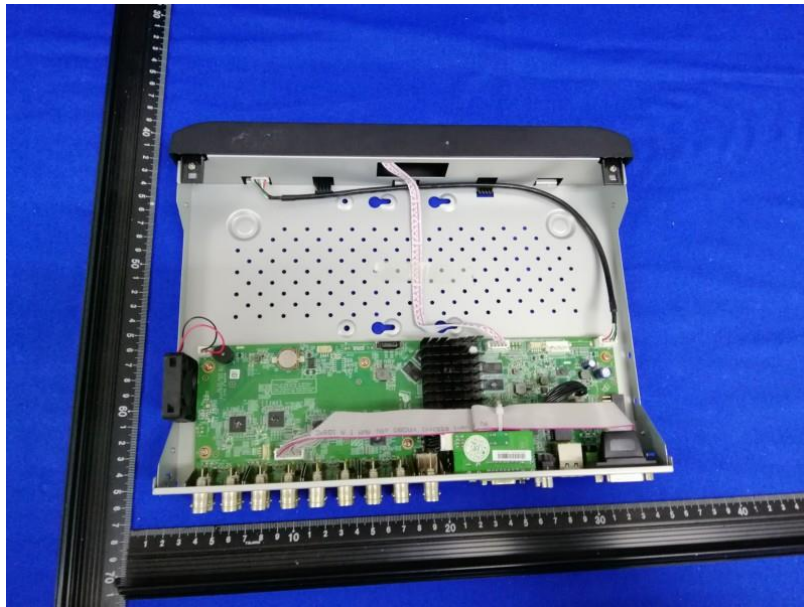
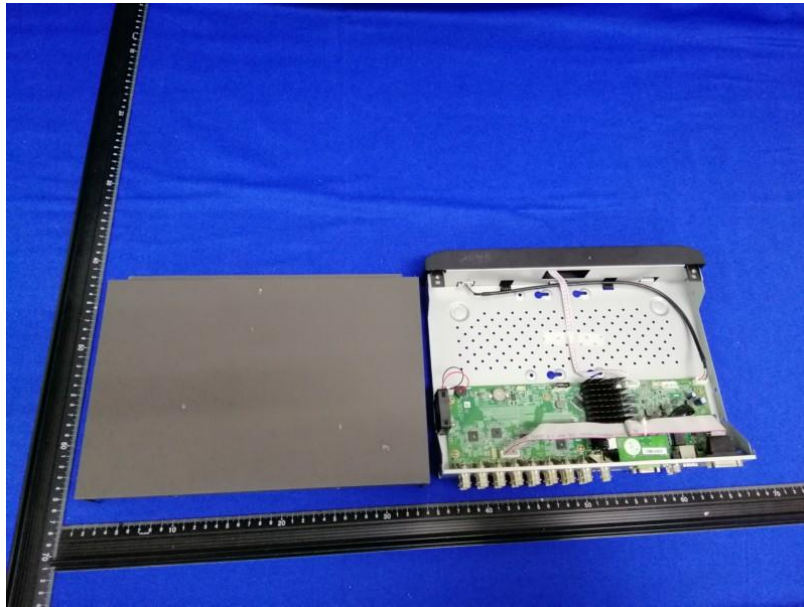

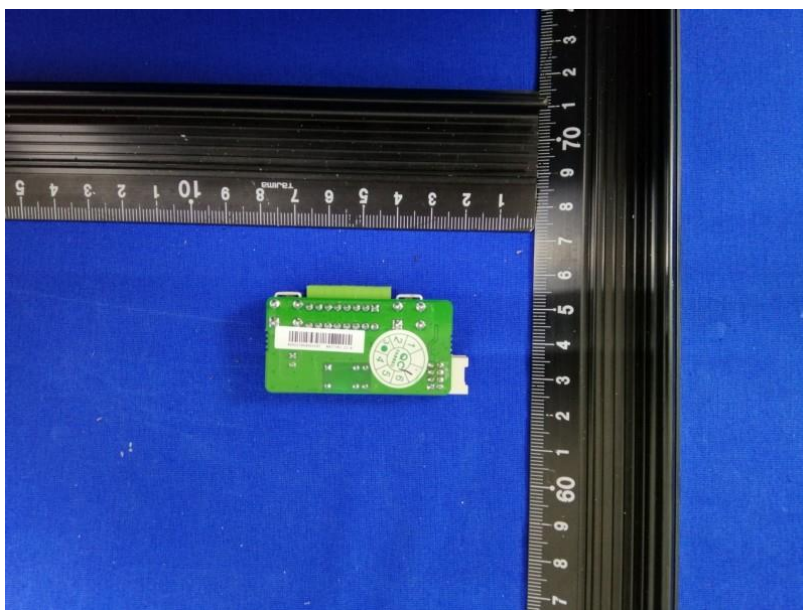
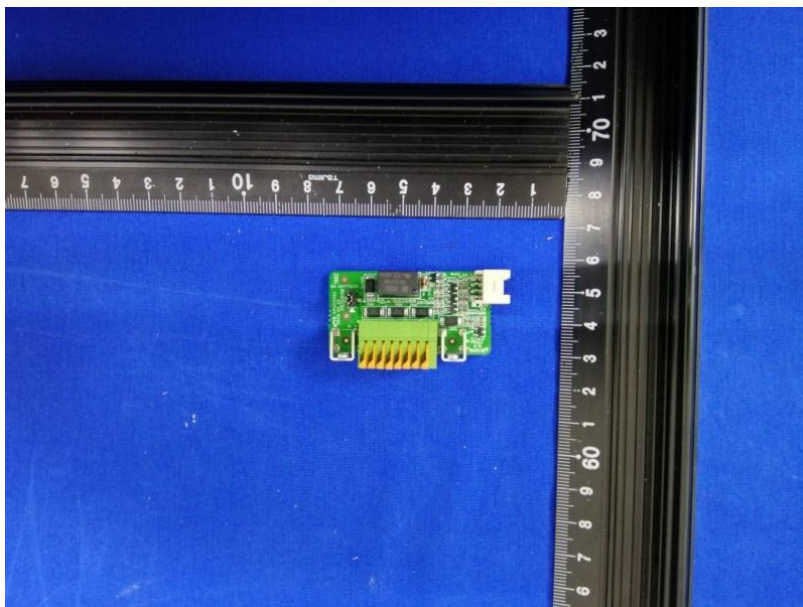

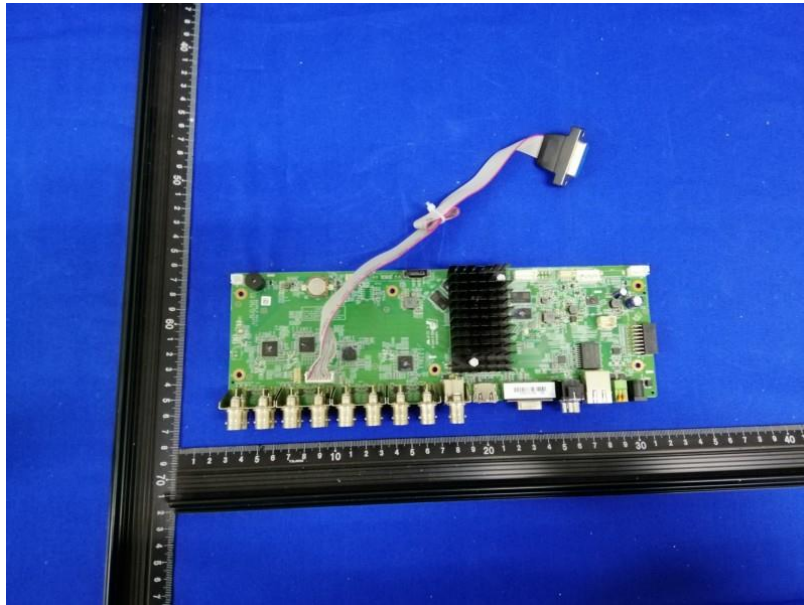

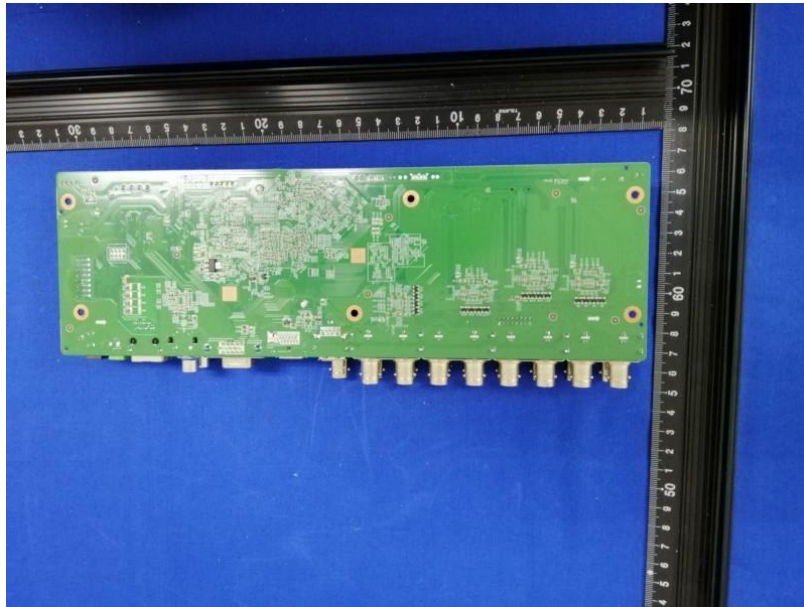

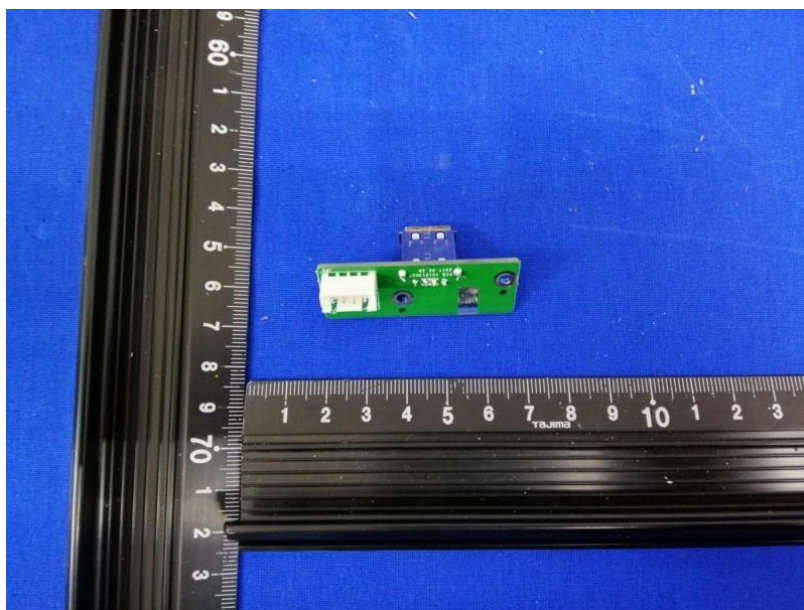
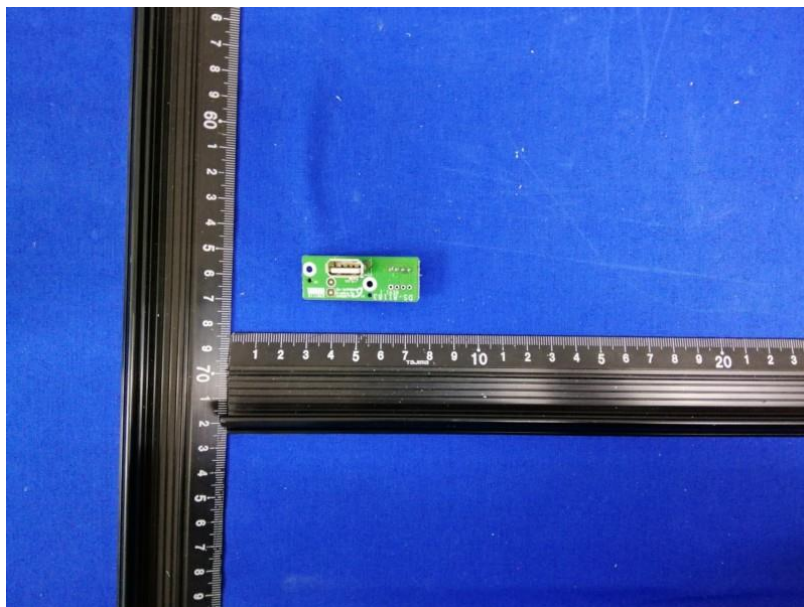



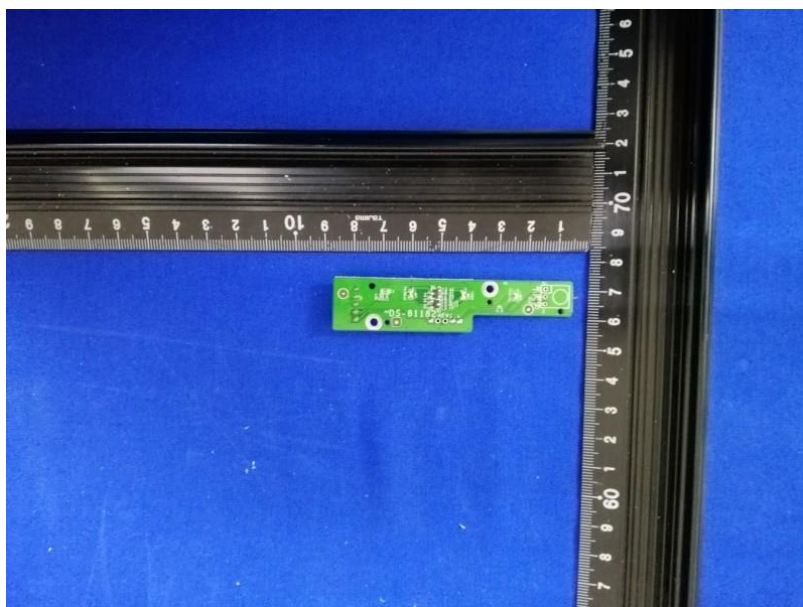
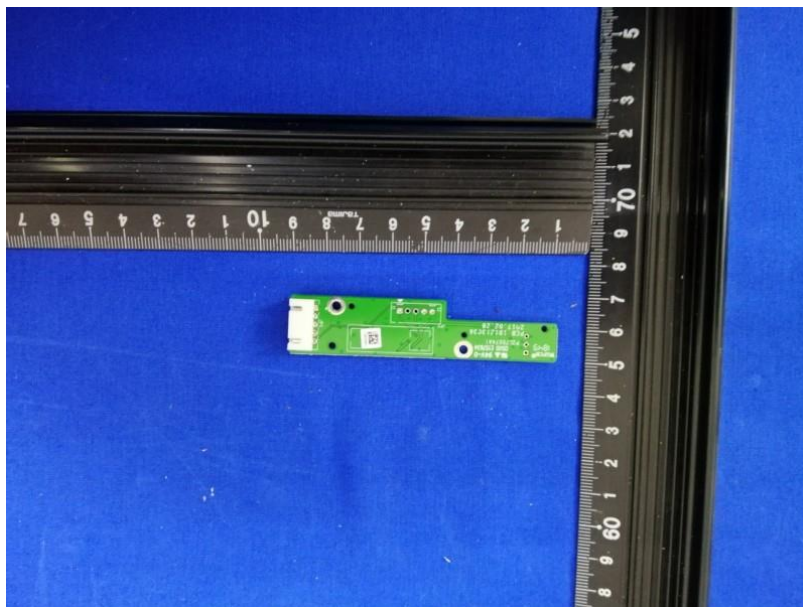

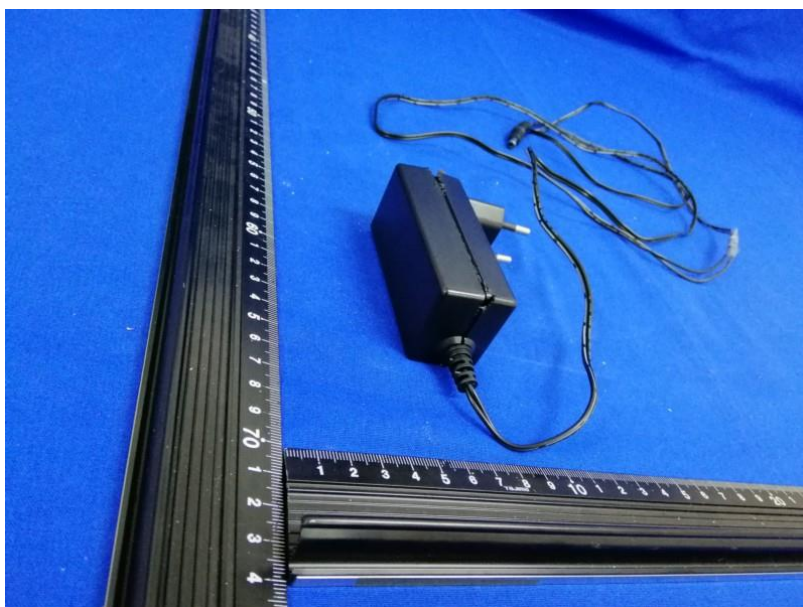

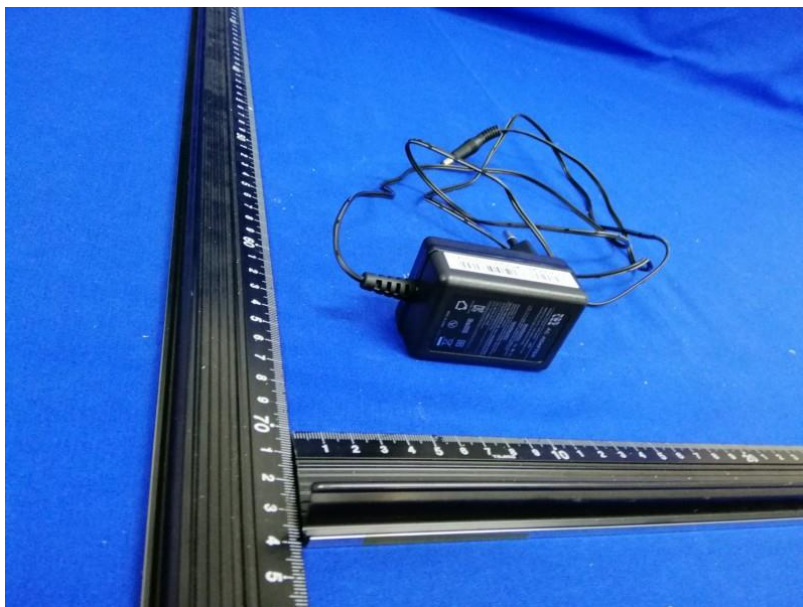

--End of the Report--