

## FCC COMPLIANCE STATEMENT

**CAUTION:** Changes or modifications not expressly approved by Digital Security Controls Ltd. could void your authority to use this equipment.

This equipment generates and uses radio frequency energy and if not installed and used properly, in strict accordance with the manufacturer's instructions, may cause interference to radio and television reception. It has been type tested and found to comply with the limits for Class B device in accordance with the specifications in Subpart "B" of Part 15 of FCC Rules, which are designed to provide reasonable protection against such interference in any residential installation. However, there is no guarantee that interference will not occur in a particular installation. If this equipment does cause interference to television or radio reception, which can be determined by turning the equipment off and on, the user is encouraged to try to correct the interference by one or more of the following measures:

- Re-orient the receiving antenna
- Relocate the alarm control with respect to the receiver
- Move the alarm control away from the receiver
- Connect the alarm control into a different outlet so that alarm control and receiver are on different circuits.

If necessary, the user should consult the dealer or an experienced radio/television technician for additional suggestions. The user may find the following booklet prepared by the FCC helpful: "How to Identify and Resolve Radio/Television Interference Problems". This booklet is available from the U.S. Government Printing Office, Washington, D.C. 20402, Stock # 004-000-00345-4.

## Industry Canada COMPLIANCE STATEMENT

This Class B digital apparatus meets all requirements of the Canadian interference-causing equipment regulations. Cet appareil numérique de la Classe B respecte toutes les exigences de règlement sur le matériel brouilleur du Canada.

## Limited Warranty

DSC warrants that for a period of one year from the date of purchase, the product shall be free of defects in material and workmanship under normal use and that in fulfillment of any breach of such warranty, DSC shall, at its option, repair or replace the defective equipment upon return of the equipment to its repair depot. This warranty applies only to defects in materials and workmanship and not to damage incurred in shipping or handling, or damage due to causes beyond the control of DSC, such as lightning, excessive voltage, mechanical shock, water damage or damage arising out of abuse, alteration or improper application of the product.

The foregoing warranty shall apply only to the original purchaser, and shall be in lieu of any and all other warranties, whether expressed or implied and of all other obligations or liabilities on the part of DSC. This warranty contains the entire warranty. DSC neither assumes responsibility for, nor authorizes any other person purporting to act on its behalf to modify or to change this warranty, nor assume for it any other warranty or liability concerning this product.

In no event shall DSC be liable for any direct, indirect or consequential damages, loss of anticipated profits, loss of time or any other losses incurred by the purchaser in connection with the purchase, installation or operation or failure of this product.

### Important!

**Test results are only valid at the time of testing. Results may vary with but are not limited to environmental and structural changes. Electrical equipment operating in the immediate area may cause interference.**



©2001 Digital Security Controls Ltd.  
Toronto • Canada • 1-800-387-3630 • [www.dsc.com](http://www.dsc.com)  
Printed in Canada 29005977 R001

# DSC® LCD5501Z32-433T NA

## Wireless Diagnostic Tester

## User Guide

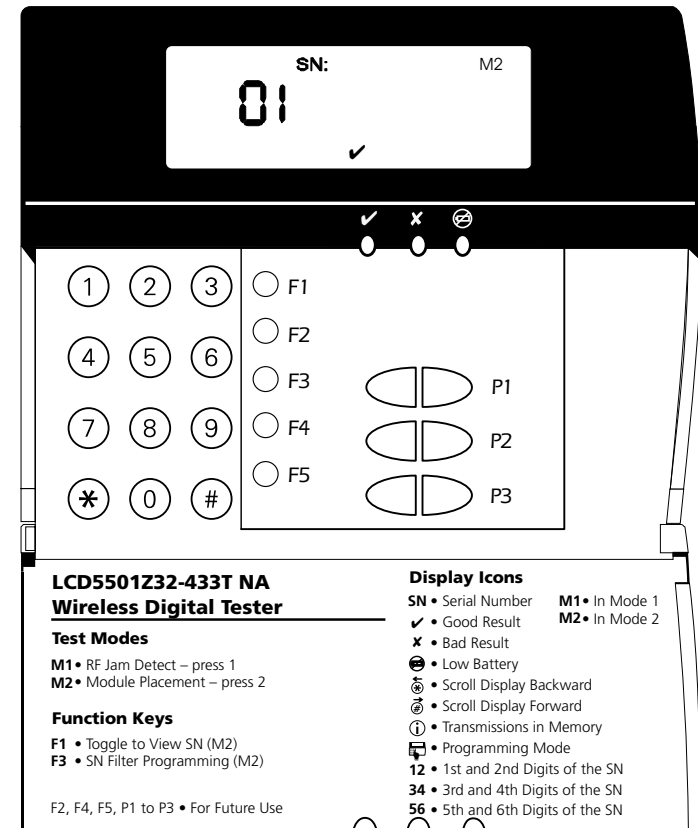

**Note!** Connect battery before use (see page 5)

**Caution!** Ensure that the unit is turned OFF after use to avoid battery damage



Warning: This document contains information on limitations regarding product use and function and information on the limitations as to liability of the manufacturer. Read the entire manually carefully.

## Table of Contents

Table of Contents .....	1
1 Introduction.....	2
1.1 Specifications .....	2
1.2 Out of the Box.....	2
2 Controls & Indicators .....	1
3 Power-up / Ready Mode .....	3
4 Mode 1 - RF Jam Detect Test .....	3
5 Mode 2 - Module Placement Test.....	4
5.1 Testing.....	4
5.2 Event Scrolling .....	4
5.3 Serial Number View .....	4
6 Serial Number Filter Programming .....	5
7 Battery Installation & Charging .....	5

## List of Illustrations

Figure 1 - Controls & Indicators.....	1
Figure 2 - Battery Installation.....	5

## List of Tables

Table 1 - Key Functions .....	2
-------------------------------	---

## 6 Serial Number Filter Programming

The Serial Number Filter programming section allows the user to manually program a serial number to use as a filter. To program the serial number filter, press the F3 key. This section has a value of 000000 programmed by default, which disables the serial number filter, with the result that the unit will use all data from received RF transmissions in the selected test. If the user enters a specific serial number in this location (other than 000000) then the unit will only use data from that particular device for the selected test. This option only applies to mode 2. Refer to Table 1 for key functions.

## 7 Battery Installation & Charging

Figure 2 - Battery Installation

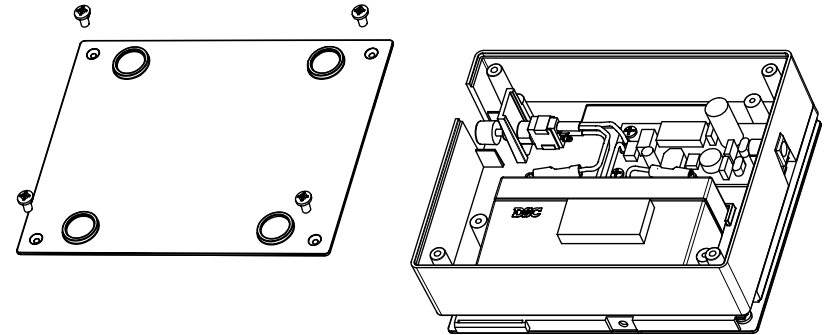

### Battery Connection or Replacement

- (1) Ensure unit is switched OFF.
- (2) Remove the four screws securing the back cover.
- (3) Remove/replace the battery if required.

#### Caution

Observe correct polarity when connecting battery. Damage may result to the tester and batteries if correct polarity is not observed.

- (4) Replace cover.
- (5) Power up device as instructed.

### Battery Charging

Battery PN - BD 1.2.3.....	6Vdc, 1.2 Ah
Battery life (Backlight Off).....	10 hr (MAX)
Battery life (Backlight On).....	6 hr (MAX)
Charging Time.....	6 hr (Max)

Note: Turn power to unit off to ensure proper battery charging.  
Only use adaptors rated for this unit.....0.9VA (9V AC/DC @ 100 mA).

Note: Battery must be turned OFF within 2 Hrs after a low voltage indication has been detected to avoid damage to the battery.

## 5 Mode 2 - Module Placement Test

The module placement test is used to evaluate the quality of placement of the RF devices. This test can be performed with the transmitter provided or with in-place wireless detectors. See 'Serial Number Filter Programming' on page 5.

When testing existing wireless devices, the unit will count the number of received RF transmissions for a single event and give a good (✓) or bad (✗) result for each. The unit has an event memory that can store up to 32 status (open/close) transmissions. When the test is in progress the unit will give real-time 'good' or 'bad' results. The user ends the test by pressing either the [\*] or [#] keys. Exiting mode 2 will clear the event memory.

### NOTE

*In mode 2, the tester counts the number of received event transmissions from a device and displays the result. Using the constant signal source transmitter (provided), the LCD5501Z32-433T will ONLY count the status (open/close) transmissions for the placement result. Supervisories that are sent at one second intervals are ignored.*

### 5.1 Testing

1. Install batteries in the WLS925L-433.
2. Place the LCD5501Z32-433T at the intended location of the receiver.
3. Place the transmitter at the intended location of the wireless detector. Activate the reed switch with the magnet (see WLS925L-433 *Installation Instructions* for location of the reed switch).
4. Press F1 to toggle to Serial Number View menu for current event.

### NOTE

*The LCD5501Z32-433T will give one result for each time the magnet is placed and removed from the reed switch. The result may take up to 5 seconds to be annunciated.*

### 5.2 Event Scrolling

After the test has ended, the number of the most recent event (01 to 32) will appear on the display. The user is now able to scroll forward and backward through the events using the \* and # keys (Event Scroll menu).

Key functions in mode 2 while **Event Scrolling** is active:

- [\*] Scroll back one event.
- [#] Scroll forward one event.
- F1 Toggle to Serial Number View menu for current event.
- [4] Return to Ready mode.

### 5.3 Serial Number View

The serial number of the device that caused the event can be viewed by scrolling to the desired event number, then pressing the F1 key. In the **Serial Number View** menu the 'SN:' icon will appear at the top of the display indicating that the serial number is being displayed. The serial number digit places currently being viewed will be displayed to the right of the SN: icon. The [\*] and [#] keys are used in this menu to scroll through the serial number digits since only two of the 6 digits are available to be viewed at once.

Key functions in mode 2 while the **Serial Number View** menu is active:

- [\*] Scroll back two serial number digits (to beginning of the serial number).
- [#] Scroll forward two serial number digits (to end of the serial number).
- F1 Toggle back to Event Scroll menu.
- [4] Exit - Return to Ready mode.

## 1 Introduction

The LCD5501Z32-433T wireless tester is intended for use with the DSC WLS9xx-433 series wireless detectors. The wireless tester enables an installer to: evaluate the suitability of a location for a wireless detection system; determine the optimal placement of wireless detection devices; and test the signal strength of individual wireless devices. The unit performs two distinct testing functions:

1. **Mode 1 - RF Jam Detect** - This mode measures the RF noise level of a location. RF Jam Detect can be used to determine the suitability of a location for the installation of a wireless system and to detect RF interference when troubleshooting the system.
2. **Mode 2 - Module Placement** - The module placement test is used to evaluate the quality of placement of the RF detectors. The module placement test can be performed with the transmitter provided or with in-place wireless detectors.

### 1.1 Specifications

Operating Temperature Range . . . . . 32° - 122°F (0° - 50°C)  
 Battery Life (backlight OFF) . . . . . 10 Hrs. (max.)  
 Battery Life (backlight ON) . . . . . 6 Hrs. (max.)  
 Battery Charging Time . . . . . 6 Hrs. (max.)

### 1.2 Out of the Box

- 1 LCD5501Z32-433T
- 1 BD 1.2-6 (6Vdc 1.2Ah) rechargeable battery
- 1 Plug-in transformer
- 1 Automobile adaptor (for battery charging)
- 1 WLS925L-433 Mini Door/Window contact

## 2 Controls & Indicators

The LCD5501Z32-433T is operated from the keypad. The keypad consists of numeric keys (0-9, \* and #), five function keys (F1 - F5), three programming keys (P1 - P3), an LCD (liquid crystal display) and buzzer. The function of the keys is determined by the operating mode as indicated in table 1. The buzzer is used to indicate key presses and the LCD displays the operating mode and other data as indicated in figure 1.

Figure 1 - Controls and Indicators

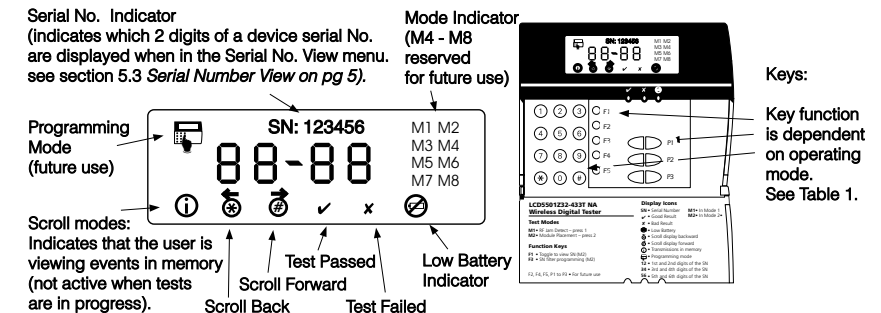

**Table 1 - Key Functions**

Key	Functions
<b>1</b>	Selects or restarts mode 1 if in modes 1 or 2. Enters decimal '1' or hexadecimal 'A' in the serial number programming section.
<b>2</b>	Selects or restarts mode 2 if in modes 1 or 2. Enters decimal '2' or hexadecimal 'B' in the serial number programming section.
<b>3</b>	Enters decimal '3' or hexadecimal 'C' in the serial number programming section.
<b>4</b>	Factory programming in modes 1 and 2. Press '#' to return to <b>Ready</b> mode. Enters decimal '4' or hexadecimal 'D' in the serial number programming section.
<b>5</b>	Factory programming in modes 1 and 2. Press '#' to return to <b>Ready</b> mode. Enters decimal '5' or hexadecimal 'E' in the serial number programming section.
<b>6</b>	Factory programming in modes 1 and 2. Press '#' to return to <b>Ready</b> mode. Enters decimal '6' or hexadecimal 'F' in the serial number programming section.
<b>7</b>	Factory programming in modes 1 and 2. Press '#' to return to <b>Ready</b> mode. Enters decimal '7' in the serial number programming section.
<b>8</b>	Factory programming in modes 1 and 2. Press '#' to return to <b>Ready</b> mode. Enters decimal '8' in the serial number programming section.
<b>9</b>	Factory programming in modes 1 and 2. Press '#' to return to <b>Ready</b> mode. Enters decimal '9' in the serial number programming section.
<b>0</b>	Toggles LCD backlight ON/OFF. Enters decimal '0' in the serial number programming section.
<b>*</b>	Toggles between decimal and hexadecimal for data entry in the serial number filter programming section. Returns to <b>Ready</b> mode from mode 1. Ends Test in mode 2 - <b>Testing</b> menu. Scrolls back 1 event in mode 2 - <b>Scrolling</b> menu. Scrolls back 2 serial number digits in <b>mode 2 - Serial No. View Active</b> menu.
<b>#</b>	Returns to <b>Ready</b> mode from mode 1, and the serial number filter programming section. Ends Test in mode 2 - <b>Testing</b> menu Scrolls forward 1 event in mode 2 - <b>Scrolling</b> menu Scrolls forward 2 serial number digits in <b>mode 2 - Serial No. View Active</b> menu.
<b>F1</b>	Returns to <b>Ready</b> mode from modes 1, 2 - <b>Testing</b> menu, and the serial number filter programming section. Toggles to <b>Serial Number View</b> menu for current event in mode 2 - Scrolling. Toggles back to <b>Event Scrolling</b> menu in mode 2.
<b>F2</b>	Future use
<b>F3</b>	Selects the serial number programming section
<b>F4</b>	Returns to <b>Ready</b> mode
<b>F5</b>	Future use
<b>P1-P3</b>	Future use

### 3 Power-up / Ready Mode

**1. Press the pushbutton switch on right side of the unit to power up.**

The ✓ LED, ✗ LED, Ⓜ LED and the LCD will light for one second followed by three audible beeps. After the three audible beeps the LED indicators and the display will clear followed by a (10) displayed on the right hand side of the display.

The double-digit display will count down from 10 to 00 in 1-second intervals accompanied by a beep. Upon reaching 00, three beeps will sound and the ✓ icon will be displayed, indicating that the unit is now in **Ready** mode.

During the power-up delay, the unit measures the surrounding RF noise level and uses this value as a reference.

**NOTE**

*Keys are not enabled during power-up period.  
If the unit does not power up when turned on, allow the unit more time to charge the battery.*

After the power-up timer expires, the unit enters the **Ready** mode. The unit does not perform any function while in this state.

**2. Press the [1], [2], or [3] key to enter the desired operating mode.**

**3. Press [0] key to toggle display backlighting ON/OFF as required.**

### 4 Mode 1 - RF Jam Detect Test

Mode 1 - RF Jam Detect measures the RF noise level of a location. This mode can be used to determine the suitability of a location for installation of a wireless system and for detecting RF interference when troubleshooting the system. The RF jam detect test will monitor the RF environment (noise floor) for the duration of a preprogrammed time interval (10 seconds). During this time the unit determines if the RF levels in the environment exceed a predetermined RF value.

**1. Press [1] key to enter mode 1**

**NOTE**

*Perform this test at several locations in the home. Select locations near electrical motors and electronic equipment and other high risk areas for these tests. Perform test a minimum of two times for each location.*

The Ready ✓ icon will turn off, the M1 icon will be displayed in the top right hand corner of the display and the number 10 will be displayed on the right hand side of the display. The double-digit display will count down from 10 to 00 in 1 second intervals accompanied by a beep. Upon reaching 00, three beeps will sound and the results will be displayed.

If the test is successful the ✓ icon will be displayed and the ✓ LED will light, indicating that the location is suitable for a wireless system.

If the test is unsuccessful the ✗ icon will be displayed and the ✗ LED will light, indicating that the location is NOT suitable for a wireless system.

- 2. Press the [1] key to repeat the RF Jam Detect Test or Press the [#] key to return to Ready mode or Press the [2] key to enter another operating mode.**