

PROGRAMMING GUIDE

List of Available ASCII Characters

032	048	064	080	096	112	160	176	192	208	224	240
!	1	A	Q	a	q	▣	ア	チ	ㄥ	㊿	ㄱ
033	049	065	081	097	113	161	177	193	209	225	241
"	2	B	R	b	r	ㄱ	イ	ツ	×	ㄷ	ㄹ
034	050	066	082	098	114	162	178	194	210	226	242
#	3	C	S	c	s	ㄴ	ウ	テ	ㄷ	ㄷ	ㄷ
035	051	067	083	099	115	163	179	195	211	227	243
\$	4	D	T	d	t	ㄷ	イ	ト	ㄷ	ㄷ	ㄷ
036	052	068	084	100	116	164	180	196	212	228	244
%	5	E	U	e	u	ㄷ	オ	ナ	ㄷ	ㄷ	ㄷ
037	053	069	085	101	117	165	181	197	213	229	245
&	6	F	V	f	v	ㄷ	カ	ニ	ㄷ	ㄷ	ㄷ
038	054	070	086	102	118	166	182	198	214	230	246
'	7	G	W	g	w	ㄷ	キ	ヌ	ㄷ	ㄷ	ㄷ
039	055	071	087	103	119	167	183	199	215	231	247
(<	8	H	X	h	x	ㄷ	ク	ネ	ㄷ	ㄷ	ㄷ
040	056	072	088	104	120	168	184	200	216	232	248
)	9	I	Y	i	y	ㄷ	ケ	ノ	ㄷ	ㄷ	ㄷ
041	057	073	089	105	121	169	185	201	217	233	249
*	:	J	Z	j	z	ㄷ	コ	ハ	ㄷ	ㄷ	ㄷ
042	058	074	090	106	122	170	186	202	218	234	250
+	;	K	[k	[ㄷ	サ	ヒ	ㄷ	ㄷ	ㄷ
043	059	075	091	107	123	171	187	203	219	235	251
,	<	L	¥	l	l	ㄷ	シ	フ	ㄷ	ㄷ	ㄷ
044	060	076	092	108	124	172	188	204	220	236	252
-	=	M]	m]	ㄷ	ス	ヘ	ㄷ	ㄷ	ㄷ
045	061	077	093	109	125	173	189	205	221	237	253
.	>	N	^	n	+	ㄷ	セ	ホ	ㄷ	ㄷ	ㄷ
046	062	078	094	110	126	174	190	206	222	238	254
/	?	O	_	o	←	ㄷ	ソ	マ	ㄷ	ㄷ	■
047	063	079	095	111	127	175	191	207	223	239	255

This guide is for use with the LCD-600 software version 2.0.

The LCD-600 may be used with the following DSC control panels:
PC3000/PC2550/PC2500/PC1550/PC1500.

15. Red Armed LED Display

The LCD-600 has a red "Armed" LED on the keypad which directly corresponds to the "Armed" light on the LED keypad.

16. Yellow Trouble LED Display

The LCD-600 has a yellow "Trouble" LED on the keypad which directly corresponds to the "Trouble" light on the LED keypad.

17. Open Zone Indicator

While in the bypass mode, any zone that is not bypassed but was open when the user enters [*], [1] will be seen on the display as follows..

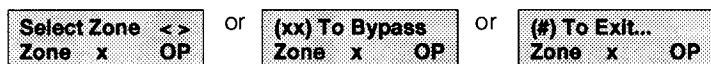

If the same zone is already bypassed or the user bypasses the zone it will then say BP instead of OP.

18. Downloading a LCD Message

The LCD is capable of accepting a downloaded message from the downloading software. The downloading package must be at least the DLS-1 V2.1 or higher. Only the PC3000 7.4 or later or the PC2550 are capable of accepting downloaded messages. The message can be 2 lines of 16 characters each.

A sample of a downloaded message is..

Please send us a
cheque for 76.34

This message will initially be displayed only when the panel is either fully armed or fully disarmed. Once the message is displayed, it will stay on until the panel is armed and disarmed three times. There is no recall feature once the message goes off the screen.

Note:

1. Any time that there is information that can be viewed by toggling the arrow keys, "< >" will be flashing.
2. The two minute timeout feature in the panel should not be used in conjunction with the LCD-600.

1. Programming the Panel

With the panel in the "disarmed" state:

- Press [*], [8].
- When prompted, enter the Installer's Code.
- The display will read..

Enter 2 Digits
For PGM Section

Numeric zone information displayed on the LCD-600 corresponds with the numbered LED's on the LED keypads. If LED #1 is ON then the LCD-600 will display a "1". If LED #2 is ON then the LCD-600 will display a "2" and so on.

With the PC3000, the numbers 10 through 15 are represented by their hexadecimal or "HEX" equivalents. Thus when LED #10 is ON, the LCD-600 will display an "A", #11 a "B", #12 - "C", #13 - "D", #14 - "E" and #15 - "F".

If a LED keypad has no LED's ON, then the LCD-600 will display a "Ø".

Enter Data
.....

The LCD-600 will display this message when expecting data using numbers "1" to "9".

Enter HEX Data
.....

The LCD-600 will display this message when expecting hexadecimal data.

Programming with an LCD-600 requires exactly the same entries as when programming with an LED keypad. Refer to the programming section of the control panel's Installation Manual.

2. Keypad Function Assignments

Each key, except 8 and 9 is assigned a function for use in LCD-600 zone label programming.

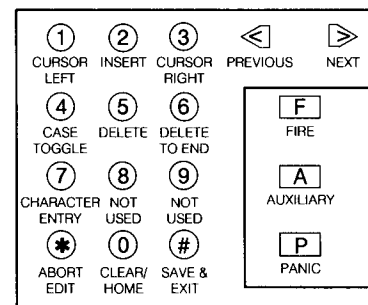

3. Programming Zone Labels

With the panel in the "disarmed" state, enter the LCD keypad programming mode as follows:

Press **[*]**, **[8]** and when prompted, enter the Installer's Code.

The display will read..

**Enter 2 Digits
for PGM Section**

Press EITHER scroll key to enter the LCD keypad programming section.

The display will read..

**LCD PGM Mode
Enter Selection**

Enter the zone number for the zone label you wish to add, change or delete.

PC3000 enter two digits 01 through 16.

PC2550 01 08.

PC2500 01 08.

PC1550 01 06.

PC1500 01 06.

The display will read..

**Zone... xx Label
Zone xx**

Default label (zone #), or..

**Zone... xx Label
"zone label"**

A programmed label "text", or..

**Zone... xx Label
.**

Blank if label erased.

Note: The cursor will always appear under the first character.

To change or add zone label text:

1. Move cursor to the character you wish to change by using the "cursor left" [1] or "cursor right" [3] keys.
2. Use the 'next character' [>] key to move forward through the alphabet and the 'previous character' [<] key to move backwards in order to select the desired character. The characters 'a' - 'z', 'A' - 'Z' and '0' - '9' can be selected with these keys. Use the "case toggle" [4] to select either 'UPPER' or 'lower' case characters.
3. A table inside the back cover shows the complete list of characters available. If a character is needed that is not selectable by the [<] [>] keys, then move the cursor to the location where you want the character and press [7] followed by the 3 digit code under the character.
4. Move the cursor to each location in turn and bring up the desired character.

Note: Maximum label length is 12 characters.

Then wire the LCD's as shown below...

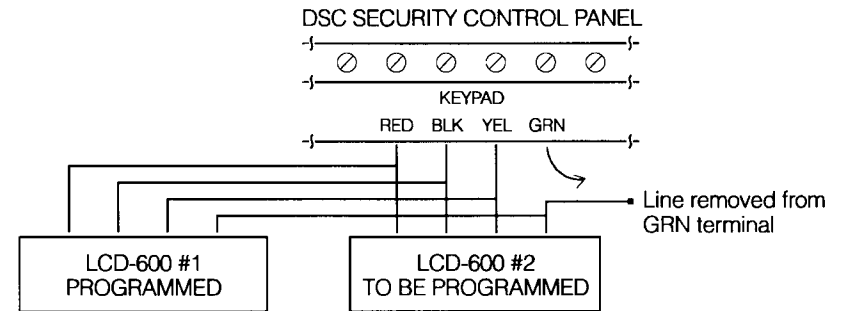

After the LCD's are wired as shown, LCD #2 will have the following message..

**LCD PGM Mode
Step 4**

Then enter [5] [0] again on LCD #1 and the following message will appear..

**LCD PGM Mode
Step 2 01**

and LCD #2 will have..

**LCD PGM Mode
Step 5 01**

These two digits will scroll from 01 to E7.

Once programming is complete, the keypads will display..

**LCD PGM Mode
Step 3 E7**

Reconnect the green wires from the keypads to the control panel and the keypads will return to normal display status.

Summary:

- Step 1 - Enter [5] [0] on keypad #1**
- Step 2 - Remove green wire from panel**
- Step 3 - Enter [5] [0] on keypad #1 again**
- Step 4 - Keypad #1 sends data to keypad #2**
- Step 5 - Reconnect green wire to panel**

11. User Scroll Mask Off Option

With the "Enter Selection" message displayed, enter [2] [3]. The display will read..

Toggle Options
XXXXXXXX

The Installer can mask off the viewing of unwanted display options by the user for the [*] [6], user options, (select) mode. If the option number is on then that message will be displayed.

Number	Message
1	Clock
2	Auto-Arm Time
3	Quick Arm On/Off
4	Auto Arm On/Off
5	Chime On/Off
6	Bell Test
7	User Call Up
8	For Future Use

Press [#] to save the new configuration and return to the "Enter Selection" message.

12. Reset LCD EEPROM to Factory Defaults

With the "Enter Selection" message displayed, enter [9] [7]. The LCD-600 will reset to factory defaults.

13. View Software Version

Viewing the version number of the software in the LCD-600 at any time other than on power-up can be done by entering [9] [9] at the "Enter Selection" message. The display will read..

VX.X
VX.X

14. Programming Other LCD Keypads

If the system has more than one LCD-600, only one needs to be programmed as described above. The other LCD-600's may be programmed using the first keypad as a master. Enter the copy mode on the programmed LCD-600 by pressing [5] [0] with the "Enter Selection" message on the display. Then the display on the programmed LCD-600 will read..

LCD PGM Mode
Step 1

5. When you have the zone label completed, press [#]. This will save the new zone label and return you to the "Enter Selection" message..

LCD PGM Mode
Enter selection

6. At this point you can choose to add or change another zone label or to go on to the remaining programming steps.

EDITING KEYS FUNCTION

2 INSERT	Pressing this key will allow a character to be inserted at the cursor location. The character at the cursor and all characters to the right of the cursor will be moved one space to the right leaving an open space for a new character.
5 DELETE	Pressing this key will delete the character above the cursor and characters to the right will all shift one space left.
6 DELETE	Pressing this key will erase all of the characters to the right of the cursor.
* ABORT EDIT	Pressing this key aborts the editing routine and any changes made to this point will not be saved. You will also be returned to the "Enter Selection" message.
0 CLEAR/ HOME	Pressing this key will clear the entire message and place the cursor in the leftmost position.

4. Programming the "F", "A", and "P" Keys and Display Alarms While Armed.

With the "Enter Selection" message on the display, enter "00". The display will read..

Toggle Options
0

If all options are off.

Toggle Options
1 2 3 4

If all options are on.

Toggle Options
2 4

If "A" and "Display Alarms While Armed" are on.

If light '1' is on the Fire key is enabled.

If light '2' is on the Auxiliary key is enabled.

If light '3' is on the Panic key is enabled.

Light '4' should be on if "Display Alarms While Armed" is on in the panel System Options. "Display Shunted Zones While Armed" is not supported by the LCD-600.

5. Programming the Utility Output Label

With the "Enter Selection" message on the display, enter [1] [7]. The display will read..



Program the message as described in Section 3 of this manual. (12 characters max.) This message will appear when the user enters the utility output command, [*], [7] and will remain on for the duration of the output operation, (approx. 5 seconds).

Press [#] to save the new message and return to the "Enter Selection" message.

6. Split Arm Side Labels

1. With the "Enter Selection" message displayed, enter [1] [8]. The display will read..



Program the message as described in Section 3 of this manual. Press [#] twice to return to the ready mode. To memorize this split mask, arm the side of the panel corresponding to the label in section [1] [8]. Any time only this side of the panel is armed, this message will be displayed.

2. Return to the "Enter Selection" message and enter [1] [9]. The display will read..



Program the message as described in Section 3 of this manual. This message will appear if only the other section of the system is armed.

Note: Any time the split arming zone configuration is changed in the panel, the mask must be re-memorized. To clear the split arm mask, enter [9] [6] when the selection message is on the screen. Then arm and disarm the side corresponding to section [1] [8].

3. When the panel is fully armed the following message will be on the display..

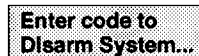

Other messages will toggle with this one. These are Fire Zone Trouble, At-Home Arming, and Bypass Active.

7. Message Language

Some models of the LCD-600 can display messages in different languages. The languages available can be viewed by pressing and holding both arrow keys. The keypad will beep three times and will display "language < >". Press either arrow key to scroll through the available languages. The list contains only the English name of each language. Pressing the [#] key when the desired language is displayed, will change the display messages to that language.

8. Backlite Control

With the "Enter Selection" message displayed, enter [2] [0]. The display will read..



Toggleing the right arrow key will decrease the backlite level to 0. Toggleing the left arrow key increases the backlite level to 9.

Press [#] to save the new level and return to the selection message.

9. Contrast Control

With the "Enter Selection" message displayed, enter [2] [1]. The display will read..



Toggleing the right arrow key will decrease the contrast level to 0. Toggleing the left arrow key increases the contrast level to 9.

Press [#] to save the new level and return to the "Enter Selection" message.

10. Masking Off Unwanted User Options

With the "Enter Selection" message displayed, enter [2][2]. The display will read..



The Installer can mask off the viewing of unwanted display options by the user for the [*] (select) mode. If the option number is on, then that message will be displayed.

Number	Message
1	Trouble
2	Memory
3	Reset Sensors (User Call Up; PC 1500/1550)
4	Access Codes
5	User Functions
6	Utility Message (programmable)
7	At-Home Arm
8	Quick Arm

Press [#] to save the new configuration and return to the "Enter Selection" message.