

MAXSYS™

PC4010CF v3.0 • Commercial Fire Installation Guide

DLS-2 v1.3

Table of Contents

Section 1: Introduction	1	Appendix A: Wiring Diagrams	14
1.1 Introduction	1	A.1 PC4010CF Wiring Diagram (Ground Connection, Zone Circuits)	14
1.2 Hardware Description and Specifications	1	A.2 PC4701 Wiring Diagram (Waterflow and 2-Wire Smoke)	15
Section 2: Fire Zone Types	3	A.3 PC4010CF Communications Connections (LINKS1000, PC4701, LINKS2150, LINKS2450)	16
2.1 Partitions and Fire System Configuration	3	A.4 PC4702BP Wiring Diagram	17
2.2 Standard Fire Zone	3	A.5 Battery Lead and AC power Lead Routing for Commercial Fire Systems	17
2.3 Delayed Fire Zone	3	A.6 Sensor Reset for 4-Wire Smoke Detectors	18
2.4 Auto Verify Fire	4	A.7 PGM Connections	18
2.5 Waterflow Zone	4	A.8 AMS-220 Addressable Smoke Detector Connection ...	18
2.6 Fire Supervisory Zone	5		
2.7 PC4701 Zones	5		
2.8 4-Wire Smoke Detector Zones	5		
2.9 AMS-220 Addressable Smoke Detector Zones	5		
Section 3: PC4702BP Output Programming	6		
3.1 Alarm Notification Output Types	6		
3.2 Programming PC4702BP Outputs	6		
3.3 Fire Bell Options	6		
3.4 Partitions and Fire System Configuration	7		
Section 4: Fire System Operation	8		
4.1 Manual Signal Silence	8		
4.2 Automatic Signal Silence (Bell Cut-Off)	8		
4.3 Signal Silence Inhibit Timer (Fire Silence Delay)	8		
4.4 Fire System Reset	8		
4.5 Manual Sensor Reset ([*][7][2])	8		
4.6 Subsequent Alarm Operation	9		
4.7 Fire Silence/Reset User Codes	9		
4.8 Auto-Scroll LCD Keypad Display	9		
4.9 Fire Trouble Conditions	9		
4.10 AC Delays	10		
4.11 Bypassing Fire Zones	10		
4.12 Fire Drill Feature	10		
4.13 Fire Inspector Test	11		
4.14 Testing AMS-220/220T Smoke Detectors	11		
4.15 Lamp Test	11		
4.16 PC4701 Remote Station Alarm/Trouble Relays	12		
4.17 Fire Reporting Codes	12		
4.18 Upload / Download Considerations	13		

Section 1: Introduction

1.1 Introduction

The PC4010CF is a ULC listed combination fire, burglary and access control panel. When used as a fire panel, all fire functions must be configured to take priority over Burglary, Access Control and other auxiliary functions.

The PC4010CF has a number of system functions established as default values. These functions must be maintained to ensure the Life-Safety integrity of the installation meets all applicable codes and standards.

To ensure an appropriate installation, all applicable NFPA and local codes and standards should be reviewed. Local AHJ (Authority Having Jurisdiction) should also be consulted prior to installation to determine specific local requirements for a fire alarm installation.

Information in this manual is intended to describe the fire functionality of the equipment. Further information on the overall system is contained in the companion manuals for this product and must be consulted for a full understanding of operation, installation and programming.

This manual lists a number of alarm initiating and alarm notification devices for use with this equipment. Use of devices other than those listed herein must be carefully evaluated for compatibility. 2-wire smoke detectors other than those listed in this manual cannot be used without voiding the listing status of the equipment.

Remote downloading of a fire panel, once it has been put into operation and is protecting a premises, is severely limited. See the Upload/Download section of this manual for information on this topic.

1.2 Hardware Description and Specifications

PC4010CF - Main Panel

- One - PC4050CR – red cabinet 14.8" x 12.0" x 4.9" with space for two 12V, 7Ah sealed lead-acid rechargeable battery
- One - PC4010 Main Control Module which includes:
 - 8 zones programmable for Fire or Burglary
 - One Programmable Output (programmable as an addressable device loop):
 - 12 VDC, 50 mA max. each (standard output) or
 - 12 VDC, 170 mA max. each (addressable loops)
 - One switched AUX Power Supply – 12 VDC, 300 mA max.
 - One unswitched AUX Power Supply – 12 VDC, 500 mA max.
 - One Supervised Bell circuit – 12 VDC, 700 mA max.
 - Supervised Battery Charger – 12 VDC, 350 mA charging current (continuous); 400mA max.
 - Supervised Telephone Communicator (connects to PC4701 module)

- One - Power Transformer – 16.5 VAC, 40 VA
- One - Hardware package which includes:
 - 16 EOL resistors (5,600Ω)
 - One Black cabinet plug
 - One green grounding strap
 - Mounting hardware for the PC4010A PCB

NOTE: The Escort4580 cannot be used with PC4010CF panels.

PC4701 - Fire Module

- One – Two-Wire Smoke detection zone
 - Class 'B' / Style 'B'
 - Accommodates up to 30 – 12 VDC 2-wire smoke detectors.
- One – Waterflow zone – Class 'B' / Style 'B'
- Two – Supervised Communicator outputs
- One – Fire Alarm actuated relay:
Form 'C', rated 2A, 30 VDC
- One – Fire Trouble actuated relay:
Form 'C', rated 2A, 30 VDC
- Terminal connections for house telephone
- Hardware to mount the module to the sidewall of the PC4050CR enclosure

PC4702BP - Bell Panel

- One - PC4052CR Red cabinet – 12" x 12" x 5" with space for two 12 VDC, 4.0Ah sealed lead-acid rechargeable batteries
- One PC4702 Dual Bell Zone module which includes:
 - Two supervised Class 'B' / Style 'Y' Bell outputs – 24 VDC FWR, 1.8A each. Outputs supervised for opens, shorts and ground with self-restoring short protection
 - Supervised battery charger, 24 VDC, 350 mA charging current for sealed lead-acid rechargeable batteries
 - Power transformer – 28 VAC, 175 VA (mounted in cabinet)
 - Combus connection terminals
 - Hardware for mounting PC4702 module.

LCD4520 - Fire Keypad

Standard LCD keypad with red bezel for use with the PC4010CF

LCD4521 - Fire Keypad with Function Keys

LCD keypad with red lens and five function keys:

- Silence Trouble
- Silence Bells
- Fire Reset
- Fire Drill
- Lamp Test

NOTE: At least one LCD4520 or LCD4521 keypad must be used with the PC4010CF.

NOTE: Maximum keypad current draw 55mA

PC4204CF – Power Supply/Relay Module For Fire

- One - PC4052CR red cabinet – 12" x 12" x 5" with space for two 12 volt, 7.0 Ah sealed lead-acid rechargeable battery
- One - PC4204 Power Supply/Relay Module which includes:
 - Four programmable relays rated 2 A, 30 VDC
 - Unswitched Aux. Power Supply – 12 VDC, 550mA max.
 - NC tamper input
 - Supervised battery charger – 12 VDC, 350mA charging current for sealed lead-acid rechargeable batteries
- One – Power transformer – 16 VAC, 40 VA

PS4350 – External Battery Charger

- PC4055C beige cabinet - 15.0" x 15.0" x 6.9"
- PS4085 multi-rate charger module
- PT1012 transformer, 12 VAC, 160 VA
- Space for 60Ah, 12 volt sealed lead-acid battery

PC4612 – Fire Zone Annunciator (12 Zones)

Surface-mount LCD style plastic housing for Fire Zone Annunciation includes:

- 10 Fire Alarm zone (Red indicators)
- Two – Fire Supervisory zone (Yellow indicators)
- One – common Bell zone Trouble (Yellow indicator)
- One – common Fire zone Trouble (Yellow indicator)
- One – common System Trouble (Yellow indicator)
- One – AC ON (green indicator)
- One – set user zone ID peel & stick labels

PC4632 – Point/Graphic Annunciator (32 Zones)

One – PC4032C surface mount beige cabinet 10.3" x 13.3" x 2.6" includes:

- Continuous hinged, screw closure front panel
- One – PC4216, 16 zone Low-Power Output module – 12 VDC, 50 mA per output
- One – PC4600LG, Pkg. Of four LED grids, covers entire display area
- One – PC4600LA-M, Pkg. Of 10 red, five yellow and one green LED assemblies
- One – PC4632GP, Point/Graphic Display package
- Capacity – for two PC4216 output modules (for 32 zones)

PC4632FT – Flush Trim For PC4632

Provides 0.75" (2cm) matching trim all round the PC4632 annunciator

PC4664 – Point/Graphic Annunciator (64 Zones)

One – PC4064C surface mount beige cabinet 18.7" x 13.3" x 2.6" includes:

- Continuous hinged, screw closure front panel
- Two – PC4216, 16 zone Low-Power Output module – 12 VDC, 50 mA per output
- Two – PC4600LG, Pkg. of 4 LED grids, covers entire display area
- One – PC4600LA-M, Pkg. of 10 red, five yellow and one green LED assemblies
- One – PC4600LA, Pkg. of 16 red LED assemblies
- One – PC4664GP, Point/Graphic Display package.

- Capacity – for four PC4216 output modules (for 64 zones)

PC4664FT – Flush Trim For PC4664

Provides 0.75" (2cm) matching trim all round the PC4664 annunciator

Other System Modules

The following modules may be added to the basic system to expand the zone capacity and add other functions.

- PC4108A – 8 zone expansion module
- PC4116 – 16 zone expansion module
- PC4164-RS – 64 zone Wireless Receiver
- PC4216 – 16 zone Low-Power output module
- PC4204 – Power Supply and quad relay module (non-fire)
- LCD4500 – LCD Keypad (non-fire)
- LCD4501 – LCD Keypad with five function keys (non-fire)
- PC4400 – Printer interface and DVAC module
- PC4820 – Dual Card Reader Access Control module
- LINKS1000 – Cellular backup communicator panel
- LINKS2150/2450 – Long-Range Radio communicator

Compatible Smoke Detectors

Please see the Device Compatibility Listing Sheet (part no. 29003936) for a list of 2-wire smoke detectors that have been listed as compatible with the PC4701 Fire module two-wire smoke detection zone.

Alarm Notification Appliances

Please see the Device Compatibility Listing Sheet (part no. 29003936) for a list of Audible and Visual Alarm Notification Appliances recommended for use with the PC4702BP Alarm Notification panel.

Section 2: Fire Zone Types

This section explains all Fire zones that can be programmed on the PC4010 and all zone expansion modules. Fire zone programming is the same as burglary zone programming. Instructions on zone programming are located in the PC4010 Installation Manual, Section 5 “Partitions and Zones.”

NOTE: Do not turn off the “Audible” zone attribute for fire zones.

NOTE: 2-wire smoke detectors cannot be used on panel or expansion zones. 2-wire smokes can only be connected to the dedicated 2-wire smoke zone on the PC4701.

2.1 Partitions and Fire System Configuration

A fire system within a single building must not be partitioned such that audible or visual alarm notification appliances would operate in one partition and not another.

Even though the system may be partitioned for security control purposes, any fire zone on any partition in the building must activate all fire alarm notification appliances in all system partitions.

The PC4010 provides two methods for achieving these results.

Fire Configuration 1

- Assign all fire zones to one partition. Do not program fire zones as ‘silent’.
- Assign all PC4702 Bell zones to the same Partition as the fire zones.
- Assign at least one fire keypad to the same partition as the fire zones.
- Zones on the PC4701 module are always global and do not require partition assignment.
- Other types of zones may also be assigned to this partition without affecting the fire operation as described below.

Operation

On alarm, from any fire zone in this partition, the fire auto-scroll display will only show on keypads assigned to the fire partition and on any system global keypads.

The waterflow and 2-wire smoke zones on the PC4701 module will show, in the auto-scroll mode, on all partition and global keypads. If a zone on the PC4701 is in alarm, then fire silence and reset can be done from any partition keypad.

If the alarm is from a partition zone (not PC4701) then fire alarm silence and reset can only be done directly on the fire partition keypad(s). To silence from other partition keypads or a global keypad requires that the keypad be loaned to the fire partition.

Fire Configuration 2 (Recommended)

- Assign ALL fire zones to ALL active partitions in the system. Do not program fire zones as ‘silent’.
- PC4702 Bell zones automatically respond to any fire zone in the system and can be assigned to any partition.
- Zones on the PC4701 module are always global and do not require partition assignment.
- One or more fire keypads may be located on any partition.

Operation

On alarm, the fire auto-scroll display will show on all partition keypads and on all global keypads.

Fire alarm silence and fire system reset may be done directly on any partition keypad. To silence from a global keypad requires that the global keypad be loaned to one of the partitions.

NOTE: Assign command output 2 (sensor reset) to all partitions.

2.2 Standard Fire Zone

All 64 zones can be programmed as Standard Fire zones. This zone is always an end-of-line resistor type with normally open alarm contacts from the alarm initiating device(s). Multiple devices may be connected in parallel on a single zone.

The zone wiring is supervised by the control panel for:

- Short Circuit: Fire Alarm
- Open Circuit: loss of the end-of-line resistor and will be indicated as a Zone Trouble
- Ground Fault: resistance < 40kΩ to earth ground indicated as a Common Ground Fault Trouble.

Typical Fire Devices used on this zone type are:

- Heat Detectors – Fixed Temperature and/or Rate-of-Rise
- Manual pull stations
- 4-wire smoke detectors
- WLS906 Wireless Smoke Detectors
- AMS-220 smoke detectors on an addressable loop

Standard Fire Operation

When a Standard Fire zone goes into alarm, the panel will activate the alarm notification output(s) and will immediately transmit a reporting code to the central station, if programmed. The alarm notification output(s) can be programmed to pulse—one second on, one second off—or to follow another programmed alarm notification pattern (see Section 4.1 “Bell Output Types”). If an open condition is present, the panel will immediately display and communicate a trouble condition. All keypads will annunciate the trouble by activating the Trouble light and beeping twice every ten seconds. The keypads can be silenced by entering an access code.

2.3 Delayed Fire Zone

IMPORTANT NOTE: This zone type is not to be used for Commercial Fire installations. This zone type is typically used for residential installations to reduce false alarms (Ref: NFPA 72 / 1-5.4.11 Positive Alarm Sequence).

All 64 zones can be programmed as Delayed Fire zones. This type is a Contact Input Fire zone. It is always an end-of-line resistor type with Normally Open alarm contacts from the initiating device(s). Multiple devices may be connected on a single zone.

The zone wiring is supervised by the control panel for:

- Short Circuit: Fire Alarm
- Open Circuit: loss of the end-of-line resistor and will be indicated as a Zone Trouble
- Ground Fault: resistance < 40kΩ to earth ground indicated as a Common Ground Fault Trouble.

Typical fire devices used on this zone type are:

- Contacts from 4-wire Smoke Detectors
- Smoke Detectors on the Addressable Loop
- WLS906 Wireless Smoke Detectors

Delayed Fire Operation

On alarm, the alarm notification outputs will activate immediately. The transmission and event buffer log are delayed by 30 seconds to allow the user to investigate the cause. If the user acknowledges the alarm by pressing any key, the alarm notification appliances will silence, the transmission will be aborted and the event will not be logged to the event buffer.

If the smoke detector is not restored to normal within 90 seconds of the alarm being acknowledged, the alarm notification output will reactivate. The user will again have 30 seconds before the output latches and the communicator activated. A valid access code will then be required to silence the alarm notification appliances.

2.4 Auto Verify Fire

Auto verification is designed to reduce false alarms that may be generated by smoke detectors. Fire alarm initiating zones programmed as Auto Verify Fire must ONLY have smoke detectors connected to them. The Auto-Verify feature delays the alarm response by up to 90 seconds.

All 64 zones can be programmed as Auto Verify Fire zones. For zones on the main panel or zone expanders, this zone is always an end-of-line resistor type with Normally Open alarm contacts from the alarm initiating device(s). Multiple devices may be connected on a single zone.

If the **2-wire smoke auto-verify** feature is enabled in the System Toggles section (ref. # [000200]), the panel will automatically verify alarms from the 2-wire smoke circuit of the PC4701 before sounding the bells and transmitting the alarms. See the PC4701 Installation Instructions for more information.

The zone wiring is supervised by the control panel for:

- Short Circuit: Fire Alarm
- Open Circuit: loss of the end-of-line resistor and will be indicated as a Zone Trouble
- Ground Fault: resistance < 40kΩ to earth ground indicated as a Common Ground Fault Trouble.

NOTE: This zone type is *only* for smoke detectors that can be reset by the control panel. Do not mix contact type alarm initiating devices on zones programmed for Auto Verify Fire. The following devices can be used:

- 2-wire smoke detectors on the PC4701 2-Wire Smoke zone
- 4-wire smoke detectors powered from the SAUX+ output on the PC4010 main board
- 4-wire smoke detectors powered from the AUX output through a relay contact programmed for Sensor Reset on the PC4204CF module
- AMS-220 smoke detectors on the addressable loop

Auto Verification Operation

On an alarm from a smoke detection zone with the Auto-verify feature selected, the panel will automatically perform a sensor reset for 20 seconds. Upon release of the sensor reset, 10 seconds are allowed for the smoke detectors to settle. During this 30-second period, no alarms will be received from any system Auto Verify Fire zone.

For 60 seconds after the 10 second settling time, if any smoke detector in the system goes into alarm, the panel will immediately initiate the full fire alarm sequence. If the 60-second window expires without any smoke detector alarms, any subsequent smoke detector alarms from Auto Verify Fire zones will reinitiate the Auto-Verify cycle.

If at any time during the Auto-verify cycle an Alarm is received from any other Fire zone, the auto verification cycle will be terminated and the panel will immediately go into the full fire alarm sequence. Once the panel is in alarm, the Auto verification sequence will be ignored and any alarm from an Auto-Verify zone will be transmitted immediately. The auto verification sequence is only restored once a Fire Reset has been performed.

2.5 Waterflow Zone

All 64 zones can be programmed as Waterflow Fire zones. The PC4701 has one dedicated Waterflow zone. This type is a Contact Input Fire Zone and is always an end-of-line resistor type with Normally Open Alarm Contacts from the initiating device(s). A maximum of five waterflow contacts can be connected in parallel on a single Waterflow zone.

The zone wiring is supervised by the control panel for:

- Short Circuit: Fire Alarm
- Open Circuit: loss of the end-of-line resistor and will be indicated as a Zone Trouble
- Ground Fault: resistance < 40kΩ to earth ground indicated as a Common Ground Fault Trouble.

Typical alarm initiating devices used on this zone type are waterflow switches for Fire Suppression sprinklers

NOTE: For this type of zone, only waterflow alarm initiating devices can be connected. A maximum of five (5) waterflow alarm initiating devices is allowed per zone (Ref: NFPA 72 / 5-6 and 3.8.5).

Waterflow Delay

Ref #: [00020309]

This delay is to prevent false alarms due to surges in the sprinkler system. The Waterflow delay is automatically applied to the Waterflow zone on the PC4701. For other waterflow zones, you must also enable the Waterflow Delay zone attribute.

If the Waterflow Delay is required, use the PC4701 Waterflow zones first. If delays are not required then the Waterflow delay must be set to [000].

The Maximum delay allowed is 90 seconds. The default is 000 seconds (disabled).

NOTE: *Waterflow Delay restrictions:*

The Waterflow Delay must be 90 seconds or less

Do not program the Waterflow Delay when Waterflow switches with built-in mechanical delays are used

In all cases, the total delay (from switches and programming) must not exceed 90 seconds

Do not use the Waterflow Delay for systems that employ ON/OFF type sprinkler heads

The first waterflow zone to go into alarm will start the delay timer. This timer will not restart when any subsequent Waterflow zones go into alarm. Once the timer has expired and the initiating Waterflow zone or any other Waterflow zones have not been restored, a Waterflow Fire Alarm will be initiated.

2.6 Fire Supervisory Zone

All 64 zones can be programmed for Fire Supervisory. This zone is always an end-of-line resistor type with normally open alarm contacts from the Fire Supervisory initiating devices. A maximum of 20 Fire Supervisory devices can be connected in parallel on a single zone.

The zone wiring is supervised by the control panel for:

- Short Circuit: Supervisory Off-Normal
- Open Circuit: loss of the end-of-line resistor and will be indicated as a Zone Trouble
- Ground Fault: resistance < 40kΩ to earth ground indicated as a Common Ground Fault Trouble.

A Fire Supervisory zone monitors fire critical systems to indicate when those systems are in a condition that could prevent normal operation. Most commonly monitored devices are sprinkler gate valves to ensure they are not closed thus preventing water from flowing to the sprinklers. (Ref: NFPA 72 / 3-8.6)

Fire Supervisory Operation

When the panel detects an Off-Normal Supervisory condition the keypad buzzer sounds steadily (not pulsing), and the panel communicates the trouble to the central station. Users can silence the keypad buzzer by entering an access code at a system keypad. The Off-Normal condition, however, is a latching condition and can only be restored by a Fire Reset. If the keypad buzzer is silenced, a subsequent Off-Normal Supervisory condition will restart the buzzer.

NOTE: *The maximum number of Supervisory devices per zone is 20. Supervisory and Fire initiating devices cannot be mixed on a Fire Supervisory zone.*

2.7 PC4701 Zones

PC4701 2-Wire Smoke

The 2-wire Smoke zone on the PC4701 module is the only zone in the system that can have 2-wire smoke detectors as Fire Alarm initiating devices. This zone is an end-of-line resistor type and can accommodate up to 30 compatible 2-wire smoke detectors. The zone is fixed as a 2-wire smoke zone.

The PC4701 2-wire smoke zone can be programmed as an Auto-Verify zone.

The zone wiring is supervised by the control panel for:

- Short Circuit: Fire Alarm
- Open Circuit: loss of the end-of-line resistor and will be indicated as a Zone Trouble
- Ground Fault: resistance < 40kΩ to earth ground indicated as a Common Ground Fault Trouble.

PC4701 Waterflow

The Waterflow zone on the PC4701 is a hard-coded for waterflow operation and cannot be reprogrammed.

If waterflow zones are used on the PC4010CF, the PC4701 Waterflow zone must be used first. This zone is an end-of-line resistor type with normally open alarm contacts from the Waterflow Alarm initiating devices. As per NFPA, only five Waterflow initiating devices may be connected to a single zone.

The zone wiring is supervised by the control panel for:

- Short Circuit: Fire Alarm
- Open Circuit: loss of the end-of-line resistor and will be indicated as a Zone Trouble
- Ground Fault: resistance < 40kΩ to earth ground indicated as a Common Ground Fault Trouble.

The Waterflow Delay can be programmed for the PC4701 Waterflow zone.

2.8 4-Wire Smoke Detector Zones

All 64 zones can be programmed for 4-wire smoke detectors. It is always an end-of-line resistor type with normally open alarm contacts from the Fire initiating devices. Multiple contacts may be connected in parallel on a single zone.

For commercial applications, zones used for 4-wire smoke detectors may be programmed as Standard Fire or Auto-Verify Fire zones. For residential applications, the zone may be programmed as a Delayed Fire, Standard Fire or Auto-Verify Fire types.

Power for the 4-wire smoke detectors may be derived from the switched auxiliary (SAUX+) output on the PC4010 main panel. The devices may also be powered from the PC4204CF AUX output routed through one of the relay's NC contacts. Program the Relay as Sensor Reset. For a wiring diagram, see Appendix A-6 "Sensor Reset for 4-Wire Smoke Detectors."

2.9 AMS-220 Addressable Smoke Detector Zones

The addressable multiplex loop(s) (AML) can be used for AMS-220/220T Addressable Smoke Detectors. Each detector will occupy one zone programmed for either Standard Fire or Auto-Verify Fire. The 2-wire connection is used to power the device and to communicate to and from the main panel. The AMS-220 is a non-latching, self-restoring device.

The addressable loop(s) are supervised for missing devices and by default will detect an open or short on the loop by reporting one or more devices as missing. Ground fault on the addressable loop wiring will be reported as a common ground fault trouble.

For information on programming and installing AML devices, see your PC4010 v3.0 Installation Manual.

Section 3: PC4702BP Output Programming

3.1 Alarm Notification Output Types

Each output on the PC4702BP may be programmed for one of the following output types. The system will also require that you program a partition mask for each output. Toggle on or off partitions 01-04 to select which partitions will activate the output:

IMPORTANT NOTE: *A fire system within a single building should not be partitioned so that audible or visual alarm notification appliances operate in one partition and not another. Even though the system may be partitioned for security control purposes, all fire alarm notification appliances in all system partitions MUST be activated on a fire alarm from any system partition in the building. The fire alarm portion of the system must appear to operate as a single partition.*

Steady Fire (49)

For this output type, the output will turn on steady upon any alarm from a Fire type zone with the Audible zone attribute enabled. This output type would be used for fire strobes when it is required to turn the Fire Strobe lights off when the signals are silenced.

Temporal Pattern Fire (50)

For this output type, the output will follow the standard temporal pattern upon any alarm from a Fire type zone. The temporal pattern is 0.5s ON, 0.5s OFF two times and then 0.5s ON and 1.5s OFF. This pattern is repeated until the signals are silenced.

This zone type would be used for audible fire alarm notification appliances such as horns or bells. This zone type would not be used for visual notification appliances (strobes).

CSFM Fire (51)

For this output type, the output will follow the California pattern upon an alarm from a Fire type zone. The California pattern is 10s ON and 5s OFF. This pattern is repeated until the signals are silenced.

This zone type would be used for audible fire alarm notification appliances such as horns or bells. This zone type would not be used for visual notification appliances (strobes).

Pulsed Fire (52)

For this output type, the output will activate upon an alarm from a Fire type zone. The output will pulse ON for 0.5s and OFF for 0.5s. The pulsing will continue until the signals are silenced. This zone type would be used for audible fire alarm notification appliances such as horns or bells. This zone type would not be used for visual notification appliances (strobes).

Fire Strobe (53)

For this output type, the output will turn on steadily upon an alarm from a Fire type zone with the Audible zone attribute enabled. The output will **not** turn OFF upon signal silence but only on Fire Reset.

This zone type would be used for visual fire alarm notification appliances when it is required to keep these appliances on once any audible appliances have been silenced.

3.2 Programming PC4702BP Outputs

Ref #: [000707XXYYZZ] where:

XX = PC4702 number

YY = 01-02 for Bell output 1 or 2

ZZ = 49-53 for output type

Each PC4702BP has two supervised outputs each rated at 24 VDC FWR, 2.0 Amps. The system can have up to four PC4702BP panels providing up to eight alarm notification appliances. The PC4702BP panels are connected to the main PC4010 panel via the 4-wire Combus, allowing them to be located throughout the premises.

To program the PC4702BP bell zones for one of the output types described in Section 3.1, enter the appropriate reference number and select the desired output type for that output.

NOTE: *Bell outputs on the PC4010CF or PC4204 cannot be used for commercial fire applications as they are not supervised for short circuits. These outputs could be used for Residential Fire and/or Burglary applications only.*

3.3 Fire Bell Options

Ref #: [000200] Fire Timeout (Y)

Ref #: [00020300] Bell Cut-off (004)

Ref #: [00020311] Fire Silence Del (000)

If the **Fire Timeout** system toggle option is enabled, any fire alarm will activate the alarm notification appliances for the **Bell Cut-off** time. The Bell Cut-off time is default programmed at 004 minutes. If the Fire Timeout option is disabled, a fire alarm output can only be silenced through user intervention.

NOTE: *Some jurisdictions may not allow automatic signal silencing. For these applications, disable the Fire Timeout option.*

The **Fire Silence Delay** can be programmed for jurisdictions that require a minimum time be set before a user can manually silence fire alarms. The Bell Cut-Off time must be equal to or greater than the Fire Silence Delay time. The message "SILENCE INHIBITED FOR [time remaining] MIN" will be displayed for three seconds when a user attempts to silence the alarm.

3.4 Partitions and Fire System Configuration

A fire system within a single building must not be partitioned such that audible or visual alarm notification appliances would operate in one partition and not another.

Even though the system may be partitioned for security control purposes, any fire zone on any partition in the building must activate all fire alarm notification appliances in all system partitions.

The PC4010 provides two methods for achieving these results.

Fire Configuration 1

- Assign all fire zones to one partition. Do not program fire zones as 'silent'.
- Assign all PC4702 Bell zones to the same Partition as the fire zones.
- Assign at least one fire keypad to the same partition as the fire zones.
- Zones on the PC4701 module are always global and do not require partition assignment.
- Other types of zones may also be assigned to this partition without effecting the fire operation as described below.

Operation

On alarm, from any fire zone in this partition, the fire auto-scroll display will only show on keypads assigned to the fire partition and on any system global keypads.

The waterflow and 2-wire smoke zones on the PC4701 module will show, in the auto-scroll mode, on all partition and global keypads. If a zone on the PC4701 is in alarm, then fire silence and reset can be done from any partition keypad.

If the alarm is from a partition zone (not PC4701) then fire alarm silence and reset can only be done directly on the fire partition keypad(s). To silence from other partition keypads or a global keypad requires that the keypad be loaned to the fire partition.

Fire Configuration 2 (Recommended)

- Assign ALL fire zones to ALL active partitions in the system. Do not program fire zones as 'silent'.
- PC4702 Bell zones automatically respond to any fire zone in the system and can be assigned to any partition.
- Zones on the PC4701 module are always global and do not require partition assignment.
- One or more fire keypads may be located on any partition.

Operation

On alarm, the fire auto-scroll display will show on all partition keypads and on all global keypads.

Fire alarm silence and fire system reset may be done directly on any partition keypad. To silence from a global keypad requires that the global keypad be loaned to one of the partitions.

NOTE: Assign command output 2 (sensor reset) to all partitions.

Section 4: Fire System Operation

4.1 Manual Signal Silence

Once the panel is in alarm and the alarm notification appliances are active, entering a valid user code will silence the alarm signals. If an LCD4521 keypad is used, pressing the “Silence Bells” function key then entering a valid user code will silence the signals. (see below for Valid User Code)

If the signal silence inhibit timer (Fire Silence Delay) is programmed, the user will be unable to silence the alarm notification appliances until the timer has expired. In this case, the LCD display will show “SILENCE INHIBIT XX MIN” to indicate how much time remains before silencing can be done. This display will show for three seconds and the LCD display will then return to the Auto-Scroll mode. Silencing will not deactivate any output programmed as Fire Strobe.

Once the signals are silenced, the LCD Auto-Scroll mode stops and the message “FIRE BELL HAS BEEN SILENCED” is displayed. This message will remain until any key is pressed. The “FIRE BELL HAS BEEN SILENCED” message will return 30 seconds after the last keypress.

Manual Silencing initiates a trouble condition by turning on the keypad trouble LED and sounding the keypad buzzer. The buzzer may be silenced by entering an access code.

If a Waterflow Alarm is present on the system silencing will not be possible. Instead, the system will announce, “Silence Inhibit. Waterflow Alarm.” All Waterflow Zones must be secured before the system can be silenced.

4.2 Automatic Signal Silence (Bell Cut-Off)

Ref #: [000200] Fire Timeout (default Y)

Ref #: [00020300] Bell Cut-Off (default 004 minutes)

The fire alarm notification appliances may be set to silence automatically after a programmed time. The system is default programmed to silence the notification appliances four minutes after the last initiated fire alarm. If the Fire Timeout option is disabled, the notification appliance can only be silenced manually.

The Bell Cut-off timer begins upon the first fire alarm. Each subsequent alarm will restart the timer.

If the alarm notification appliances are silenced automatically, the Auto-Scroll feature will continue and will include the following message: “FIRE BELLS HAVE BEEN SILENCED.” Outputs programmed as Fire Strobe will not deactivate on Bell Cut-off.

NOTE: *If the Fire Silence delay is programmed, the Bell Cut-off time must be set for a time equal to or greater than the Fire Silence delay time. This will ensure that the alarm notification appliances cannot be silenced manually or will not silence automatically before the Fire Silence Delay time has expired.*

Automatic silencing initiates a trouble condition by turning on the keypad trouble LED and sounding the keypad buzzer. The buzzer may be silenced by entering an access code.

4.3 Signal Silence Inhibit Timer (Fire Silence Delay)

Ref #: [000203111] Fire Silence (default 000 minutes)

When it is required that the Alarm notification appliances operate for a minimum period before they can be silenced, program the Fire Silence Delay timer for that period. Manual silencing will be inhibited for the programmed period and if a user attempts to silence before the delay expires, the LCD will display “SILENCE INHIBIT XX MIN” to indicate how much time remains before manual silencing can be done.

The Bell Cut-off timer must be disabled (Fire Timeout = N) or set to a time equal to or greater than the Fire Silence Delay time. This is to guarantee that the alarm notification appliances will not silence automatically before the Fire Silence Delay period.

4.4 Fire System Reset

Once the Fire notification appliances have been silenced (manually or automatically), the fire system may be reset by entering a valid user code. On an LCD4521 keypad, pressing the Fire reset function key then entering a valid user code will reset the system. The “Fire Silence Delay” timer will inhibit both manual silencing and reset until the delay period expires.

When the system is reset, all latched fire functions within the panel are restored and a Sensor Reset is initiated to restore all 2- and 4-wire smoke detectors. If an alarm is present at the end of the reset period, the panel will go into alarm. The Auto-Verify Fire delay and Waterflow delay are both in force after a system reset.

Fire Supervisory Off-Normal is a latched function and will be restored on system reset.

4.5 Manual Sensor Reset ([*][7][2])

Ref #: [0100XX01] Com O/P2 Rq Cd (default N)

where XX = Partition (01 to 08)

The Sensor Reset function is designed so that the user can manually reset latching smoke detectors by entering [*][7][2]. In order for this feature to function, the detectors to be reset must be connected to a programmable output (SAUX+, PC4204CF).

Program the output as “Command Output 2” (output option #39). The output pulse time is default set at five seconds. For instructions on output programming, see your PC4010 Installation Manual, Section 11 “Programmable Outputs.”

RECOMMENDED: *As a security measure, enable the Com OIP2 Rq Cd partition toggle option. This will require that a user enter a valid access code after entering [*][7][2] in order to reset smoke detectors.*

4.6 Subsequent Alarm Operation

If the alarm notification appliances have been silenced – manually or automatically – and a subsequent fire alarm is initiated, the following will occur:

- Audible and Visual notification appliances will activate as programmed.
- Auto-verification is overridden for Auto Verify Fire zones (alarms are instant).
- The Waterflow Delay is maintained for waterflow zones.
- The Bell Cut-off timer, if used, will restart for a full timing period before automatic silencing.
- The Fire Silence Delay timer, if used, will NOT restart. The silence inhibit period is not reinstated and silencing can be done without any delay.
- Auto-Scroll is initiated. The new alarm and all previous alarms/troubles will be displayed.

If a subsequent Fire alarm is initiated before the alarm notification appliances have been silenced, either manually or automatically, then the following will occur:

- Auto-Verification is overridden for zones programmed as Auto-verify types. (alarms are instant)
- The Waterflow Delay is maintained for waterflow zones.
- The Bell Cut-off timer, if used, will restart for a full timing period before automatic silencing.
- The Fire Silence Delay timer will restart for a full timing period. Silence Inhibit is extended to ensure a full period after the last alarm.
- The new alarm is added to the Auto-Scroll list.

4.7 Fire Silence/Reset User Codes

The **Silence Fire** access code toggle option is designed to limit the number of users who can Silence/Reset the Fire system. When programming access codes in the [*][5] user programming section, program this option as 'Y' for those users who will have the authority to Silence/Reset the Fire system. Select 'N' for all others. For more information regarding programming access codes, please see the PC4010 Instruction Manual.

4.8 Auto-Scroll LCD Keypad Display

When a Fire Alarm is initiated, the Alarm and selected trouble conditions will be displayed on the system LCD keypad(s). If there is more than one alarm or trouble present simultaneously, the keypad will continuously scroll through each event. Items on the scroll list are displayed at two-second intervals. The keypad will beep as each message is displayed.

Although critical troubles are displayed, Auto-Scroll is only initiated upon a Fire Alarm. If a Fire Trouble is detected and a Fire Alarm is not present, the trouble will be indicated as any other system trouble; the keypad trouble light will turn on and the keypad buzzer will beep.

The following events are included in the Auto-Scroll.

- **“First Fire Alarm [Zone Label]”**: This message will indicate which Fire Alarm was first detected by the control panel. Each time this message is displayed the keypad buzzer will beep twice to distinguish it as the first fire alarm.
- **“Fire Alarm [Zone Label]”**: This message will appear for all subsequent Fire Alarms and the keypad buzzer will beep once as the message is displayed. Messages are displayed sequentially by zone number.
- **“Supervisory [Zone Label]”**: This message will appear for Fire Supervisory Off-Normal conditions only and the keypad buzzer will beep once as it is displayed. Messages are displayed sequentially by zone number.
- **“Fire Bell Has Been Silenced”**: This message will appear in the Auto-Scroll list after the alarm notification appliances have been automatically silenced.
- **“Bell Zone Trouble”**: This message will appear if a short or open fault is detected on the PC4010 bell zone or any PC4702 output.
- **“Failure to Communicate”**: This message will appear when the panel cannot report to the Central Station.

Auto-Scroll will stop when a valid user code is entered to silence the alarm notification appliances.

4.9 Fire Trouble Conditions

In all cases, when the panel detects a trouble condition, the keypad Trouble light turns on and the keypad buzzer will sound two short beeps every 10 seconds. Entering and access code will silence the audible trouble signal. The trouble buzzer will resound if another trouble is generated.

If a PC4701 is connected to the system, and the Common Fire Trouble output is connected, the output will activate when any of the following events occur. The output will deactivate when all trouble conditions are restored.

Fire Supervisory Alarm

An Off-Normal condition on a Fire Supervisory zone will cause the PC4701 Common Fire Trouble output to activate. See “Fire Supervisory Zone” on page 5.

Fire Zone Trouble

A fire zone trouble will be generated when an open circuit is detected on any Fire zone.

Fire zone troubles are grouped for remote annunciation as “Fire Zone Trouble.” This indication can be programmed on the PC4612 Fire Zone Annunciator or on the PC4632/4664 Point/Graphic annunciators (output option #48).

Bell Trouble

A Bell trouble is generated when an open or short is detected on any PC4702BP alarm notification output. A bell trouble is also generated when an open condition is detected on the PC4010 bell output.

Bell troubles are grouped for common indication on a remote annunciator as a “Bell Zone Trouble.” This indication can be programmed on the PC4612 Fire Zone Annunciator or on the PC4632/4664 Point/Graphic annunciators (output option #56).

AC Trouble

An AC Fail trouble is generated if the AC fails on the PC4010CF main panel or on the PC4204, PC4702 or PC4820 modules. AC troubles are grouped for common indication on a remote annunciator as an "AC Trouble." This indication can be programmed on the PC4612 Fire Zone Annunciator or on the PC4632/4664 Point/Graphic annunciators (output option #56). This trouble should use a green indicator which is normally ON and turns OFF for any AC failure.

See also Section 4.10 "AC Delays."

Battery Trouble

A Battery trouble is generated if any of the following panel batteries are open or shorted: PC4010, PC4204, PC4702 and PC4820. This trouble condition only turns on the keypad Trouble light and sounds the keypad buzzer.

Ground Fault

Ground fault detection must be enabled for Commercial Fire installations by connecting the EGNB terminal on the PC4010CF to a solid earth ground. Upon detection of a resistance of <40kΩ between any extended conductor and earth ground, a Ground Fault Trouble will be generated.

Ground fault can be indicated on a PC4632/4664 Point/Graphic Annunciator (output option #54). All PGM outputs programmed as Ground Fault will turn ON.

TLM Troubles

If the PC4701 detects a TLM trouble on telephone line 1 or 2, the PC4701 Common Fire Trouble output will activate. The panel can only monitor both telephone lines if a PC4701 is connected.

NOTE: TLM trouble monitoring should not be disabled.

Fail To Communicate (FTC)

If the control panel is unable to report to the central station, an FTC trouble will be generated and the message "Failure to Communicate" will be added to the Auto-Scroll list to advise the user that the central station may not have received the communication about the current alarm status.

An FTC trouble can be indicated at a remote PC4632/4664 annunciator (output option #15).

Common Fire Troubles

The following troubles are grouped and can be mapped to a single output on the PC4612 or PC4632/4664 annunciators (output option #15).

- Any system AC Trouble (PC4010, PC4702, PC4204, PC4820)
- Any system Battery Trouble (PC4010, PC4702, PC4204, PC4820)
- Any System Communicator Trouble (TLM1, TLM2, FTC, LINKS)
- Ground Fault

4.10 AC Delays

AC Fail Delay

Ref #: [00020310] AC Fail Delay

If the **AC Fail Delay** is programmed, the panel will delay the trouble indication on keypads and remote annunciators for the programmed time (000 to 255 min.). This

delay is to avoid the annunciation of short-term AC failures. Some jurisdictions may not allow any delay for Fire installations. In this case, the timer should be left at its default setting (000 = disabled).

AC Fail TX Delay

Ref #: [00040202] AC Fail TX Delay

If the **AC Fail TX Delay** is programmed, the panel will delay reporting the AC trouble to the central station for the programmed time. This value must be set between 6 and 12 hours (0600-1200).

4.11 Bypassing Fire Zones

Fire zones may be bypassed to overcome zone problems. When a Fire zone is bypassed, a Fire Trouble will be generated and the Fire Trouble reporting code (if programmed) will be sent to the central station. If a partition is armed with a Fire Zone bypassed, the keypad will beep 10 times and the message "Fire Zone Bypassed" will appear on the keypad display for three seconds.

For instructions on bypassing zones, please see "Zone Bypassing" in the PC4010 Instruction Manual.

NOTE: The PC4701 Waterflow and 2-Wire Smoke zones cannot be bypassed. These zones are not system zones (001-064) and thus cannot be selected in the zone bypassing mode.

4.12 Fire Drill Feature

Ref #: [00040309] Fire Event reporting codes

Fire drills should be conducted on a regular basis according to the guidelines set by local fire authorities.

To initiate a fire drill, the system must be disarmed. Enter [*][6][Access Code][5] at any partition keypad. The Fire Test Begin reporting code, if programmed, will be sent to the central station.

During the test, keypads will display the message "Fire Drill in Progress." The main bell output and all PC4702 outputs will activate according to their programmed fire-signaling mode. The fire drill will neither activate any other functions (relays, etc.) nor send any other reporting codes to the central station.

The Auto-Signal Silence Timer will not be activated and the Fire Drill will continue as long as required. To end the fire drill, enter a valid access code. All alarm notification outputs will deactivate and the LCD keypad will display the message "Fire Drill Disabled" for 3 seconds. The Fire Test End reporting code, if programmed, will be transmitted to the central station.

If an actual fire alarm occurs during the fire drill, the test will be cancelled and the fire alarm sequence will begin. The keypad will display "Fire Drill Disabled" for 3 seconds and then will transfer to the Auto-Scroll mode. The Fire Test End reporting code, if programmed, will be transmitted to the central station.

Any 24-Hour Burglary alarms that occur during the Fire Drill will activate their programmed outputs and will report to the central station.

NOTE: To initiate the test from a global keypad, you must first loan the keypad to a partition. From a global keypad, press [*], then use the arrow keys (< >) to scroll to any partition label and press [*] to select it. The display will read "Keypad Loaned to [Partition Label]." Then, enter [*][6][Access Code][5] to initiate the fire drill.

4.13 Fire Inspector Test

Ref #: [00040309] Fire Event reporting codes

The Fire Inspector Test will allow the inspector and/or installer to ensure that the system's fire components are functioning as intended. The test verifies that every fire-initiating device is communicating and that they are supervised.

To initiate a Fire Inspector Test, the system must be disarmed. Enter [*][6][Walk Test Code][4] at any partition keypad. Once the test is initiated, the **Fire Test Begin** reporting code, if programmed, will be sent to the central station.

The keypad Trouble light will turn on and the keypad buzzer will beep. These trouble beeps cannot be silenced during the test. All partition keypad displays will read "Fire Insp. Test Is Active..." Any keypress will clear this message for 10 seconds.

Activate each fire sensor in turn according to the manufacturer's device testing instructions. All events are logged in the event buffer. Depending on how each fire zone is programmed, the panel will respond in the following ways:

- **Fire Alarm Or Supervisory Zone Off-Normal:** All alarms are instant, indicated by one bell squawk. Auto-Verify delays are ignored. For PC4701 2-wire Smoke zones or any PGM outputs programmed for Sensor Reset, zones not restored within 10 seconds will be reset. If the zone remains open after the sensor reset, the bell will squawk again. This sequence will repeat until the zone is restored.
- **Waterflow Zone Alarm:** If the waterflow delay is enabled, the bell squawk will occur AFTER the programmed delay period. This allows for verification of the delay period.
- **Fire and Supervisory Zone restoration:** All Fire signals sound one squawk.
- **Trouble (Open cct.) or Trouble restoration:** Bells will sound two squawks.

The Fire Inspector's Test is enabled for ONE HOUR only. Five minutes before the one-hour timeout, the bells will squawk three times every 20 seconds to signal that the test is about to end. The test time cannot be extended. If more time is required, the test must be reinitiated by entering [*][6][Walk Test Code][4] at any partition keypad.

To end the test before one hour, enter [*][6][Walk Test Code][5] at a partition keypad. The **Fire Test End** reporting code, if programmed, will be sent to the central station once this command is entered.

NOTE: To initiate the test from a global keypad, you must first loan the keypad to a partition. From a global keypad, press [*], use the arrow keys (< >) to scroll to any partition label and press [*] to select it. The display will read "Keypad Loaned to [Partition Label]." Then, enter [*][6][Walk Test Code][4] to initiate the Fire Inspector test.

4.14 Testing AMS-220/220T Smoke Detectors

AML smoke detectors continuously monitor themselves for low sensitivity and will report this condition as a device trouble.

In addition, you can test the alarm/restore capability of the detectors manually or automatically on a programmed schedule.

To manually initiate the test, perform the following:

1. Enter [*][6][Walk test code][3], or use the arrow (< >) keys to scroll to "AML Smoke Test."
2. All smoke detectors on the addressable loop(s) will perform a self test. If a detector fails, a trouble will be generated.
3. The AML smoke test takes approximately 5.5 minutes to complete. A fire alarm from any other fire zone on the system will initiate the programmed response. The AML smoke test will proceed in the background.
4. During the smoke test, the message "AML Smoke Test Is Active" will be displayed on the keypad. Pressing any key will override the display so that other events can be observed.

Scheduled Smoke Detector Test

There are 50 smoke test schedules. Each smoke test schedule is assigned a date schedule. To schedule the AML smoke detector test, perform the following:

1. Enter reference number [001402] and press [*].
2. The keypad display will read "Select Entry # / Enter 01-50." Use the arrow (< >) keys to select which Smoke Test schedule is to be programmed and press [*].
2. The keypad display will read "Enter Sch.# / Enter 00-99." Enter the date schedule you have programmed for the smoke test (valid entries are 02-99). The default date schedule for each smoke test schedule is 01 (disabled).
3. The keypad display will read "Select Toggle Partition X." Use the arrow (< >) keys to scroll through each partition and press the [*] key to toggle them on (Y) or off (N). This will activate the smoke test at the programmed time for only the selected partitions. By default, all partitions are deselected (N).

When programming a date schedule, program the time to perform the AML smoke test as the Start time for an interval. Program the end time as one minute after the start time. For example, to perform a smoke test at 8 a.m., program the Start time as 0800 and the End time as 0801. For more information regarding date schedules, see the PC4010 Installation Manual, Section 14 "Event Scheduling."

4.15 Lamp Test

You can enable the lamp test feature for each PC4216 module when it is enrolled (refer to the PC4216 Installation Instructions). A lamp test activates all PC4216 outputs for two seconds. To initiate a lamp test, enter [*][6][Access Code][8] at any partition keypad.

NOTE: To initiate the test from a global keypad, you must first loan the keypad to a partition. From a global keypad, press [*], use the arrow keys (< >) to scroll to any partition label and press [*] to select it. The display will read "Keypad Loaned to [Partition Label]." Then, enter [*][6][Access Code][8] to initiate the lamp test.

4.16 PC4701 Remote Station Alarm/Trouble Relays

The PC4701 Fire module has two relays: one that activates for all Fire zone alarms and one that deactivates for all Fire zone and system trouble conditions. These relays are provided for remote station connection. Each relay has a set of form "C" contacts rated at 2A, 30VDC.

4.17 Fire Reporting Codes

The following reporting codes should be programmed on any PC4010CF system:

Fire Events

Ref #: [00040309]

2-wire Alarm – This reporting code will be sent when a 2-wire Smoke zone alarm occurs. The 2-wire Smoke zone acts as a standard fire zone. The 2-wire Alarm Restore reporting code will be sent when the alarm condition is restored.

Waterflow Alarm – This reporting code will be sent when a Waterflow zone alarm occurs. The Waterflow Restoral reporting code will be sent when the alarm condition is restored.

2-wire Trouble – This reporting code will be sent when the 2-wire smoke detector zone has a trouble (open) condition. The 2-wire Trouble Restoral reporting code will be sent when the condition has restored.

Waterflow Trouble – This reporting code will be sent when the Waterflow detector zone has a trouble condition. The Waterflow Trouble Restoral reporting code will be sent when the condition has restored.

Fire Test Begin/End – The Fire Test Begin reporting code will be sent either:

1) when the Fire Inspector's Test is initiated by pressing [*][6][Walk Test Code][4]. This test will time out after one hour, or after it is manually ended by pressing [*][6][Walk Test Code][5].

2) the Fire Drill is initiated by pressing [*][6][Access/Master Code][5]. The Fire Drill has no Time Out and will only be ended either manually by pressing [*][6][Master/Access Code][5], or by fire alarms that occur during the test.

The Fire Test End reporting code will be sent when the Fire Inspector's ends or when after the fire drill ends.

Fire Bypass/Unbypass – The Fire Bypass reporting code will be sent when a Fire type zone is bypassed using the [*][1] keypad command. The Fire Unbypass reporting code will be sent when the zone is added back to the system.

[F] Key

Ref #: [00040306]

The panel will transmit a Keypad Fire Alarm reporting code *and* the Keypad Fire Restoral reporting code when the Fire Keys on any keypad are pressed for two seconds.

NOTE: For commercial applications, do not program the [F] key for keypads that are readily accessible by the public. For more information regarding this key, see the PC4010 Installation Manual Section 6.5 "Fire, Auxiliary and Panic Keys."

System Maintenance

Ref #: [00040316]

Panel Battery Trouble – This code will be sent when the control panel battery is low, disconnected or if the battery fuse fails. The Battery Trouble Restoral reporting code will be sent when the condition is cleared.

Panel AC Trouble – This code will be sent when the AC power to the control panel is disconnected or interrupted. To prevent communicating the trouble in the event of short power failures, the code will not be sent until the AC Failure Communication Delay has expired. When the trouble is restored, the AC Line Trouble Restoral reporting code will be sent.

Panel Bell Trouble – This code will be sent when a bell trouble occurs. This is when an open circuit is detected across the bell terminals. When the trouble condition is restored, the Main Bell Trouble Restoral reporting code will be transmitted.

Panel AUX Trouble – This code will be sent when an auxiliary voltage supply trouble occurs. When the voltage supply is restored, the Main Auxiliary Trouble Restoral code will be sent.

TLM Failure – If a LINKS unit is being used, this reporting code will be sent through the LINKS when a Telephone Line Monitoring trouble occurs. The TLM Restoral code will be sent when the condition is cleared.

NOTE: Do NOT program this code if a LINKS unit is not used. The TLM Failure Line 2 Trouble and Trouble Restoral reporting codes will be sent when a similar condition occurs on a second telephone line.

GND Fault Trouble – This reporting code will be sent when the earth ground connection detects a ground fault. The Ground Fault Restoral reporting code will be sent when the earth ground fault connection is restored.

NOTE: The PC4010 EGND terminal must not be connected to the Combustion ground. Connecting earth ground to the Combustion ground will interfere with system performance and generate a Ground Fault Trouble.

Periodic Test – This is the reporting code that is sent to the monitoring station to test communications (see PC4010 Installation Manual, Section 10.8 "Test Transmissions").

Periodic Test TBL – This test transmission code is sent instead of a Periodic Test Transmission if any of the following conditions occur:

- Common Fire Trouble
- Fire Zone Alarm (zones 001-064)
- Fire Alarm (4701)
- Fire Zone Trouble (zones 001-064, 4701)
- Fire Zone(s) Bypassed
- Fire Supervisory (AML/wireless)
- Fire Tamper / Low Sensitivity (AML/wireless)
- Fire Drill or Inspector Test
- AUX Trouble (main panel)
- Bell Trouble (main panel, 4702)
- Combustion Low Power
- Module Communication Fault
- Fire Low Battery (wireless)

- [F] Key Alarm

General System Trouble – This code will be sent when one of the following conditions occur. The code will be transmitted for the first trouble condition only.

- PC4204, PC4820 AC Trouble / restoration
- PC4204, PC4820 Battery Trouble / restoration
- PC4204, PC4820 Aux Supply Trouble
- PC4400 Trouble
- DVAC Trouble
- Automation Fault
- PC4164-RS Signal Trouble (RF Jam)

The General System Trouble Restoral reporting code will be sent when all the trouble conditions are is cleared.

4.18 Upload / Download Considerations

The PC4010 system is capable of being uploaded or downloaded over the public switched telephone network, or on site using the PC-Link. Prior to the final verification of system operation, uploading/downloading may be performed as required.

Once the system has been approved by the AHJ (Authority Having Jurisdiction), uploading/downloading can be done observing the following:

1. Remote control (via downloading) of any part of the system is not allowed (e.g. sensor reset, signal silence, zone bypassing, trouble silencing)
2. If programming changes are to be made from a remote location, a qualified individual must be on site to verify that system operation is not impaired in any way.
3. Downloading should only be initiated from the site. The **User Enabs DLS** system toggle option is enabled by default. This option will prevent any downloading from occurring without a user initiating downloading on site.
4. If an alarm occurs during a uploading/downloading session, the system will disconnect the downloading computer and activate the system as programmed and will communicate normally to the central station. If a computer is connected via the PC-Link, the system will function as programmed but an alarm will not be communicated to the central station until the PC-Link connection is removed.

NOTE: *If a DLS communication was ended abnormally, the panel will annunciate a DLS Fault trouble. The trouble will only restore after DLS has re-connected to the panel and disconnected properly.*

NOTE: *If during the downloading of system programming changes – either remotely or locally – an alarm occurs, the system may not function as intended, depending on whether the downloading was completed before the alarm. **It is imperative that system operation be verified after any programming change.***

Appendix A: Wiring Diagrams

A.1 PC4010CF Wiring Diagram (Ground Connection, Zone Circuits)

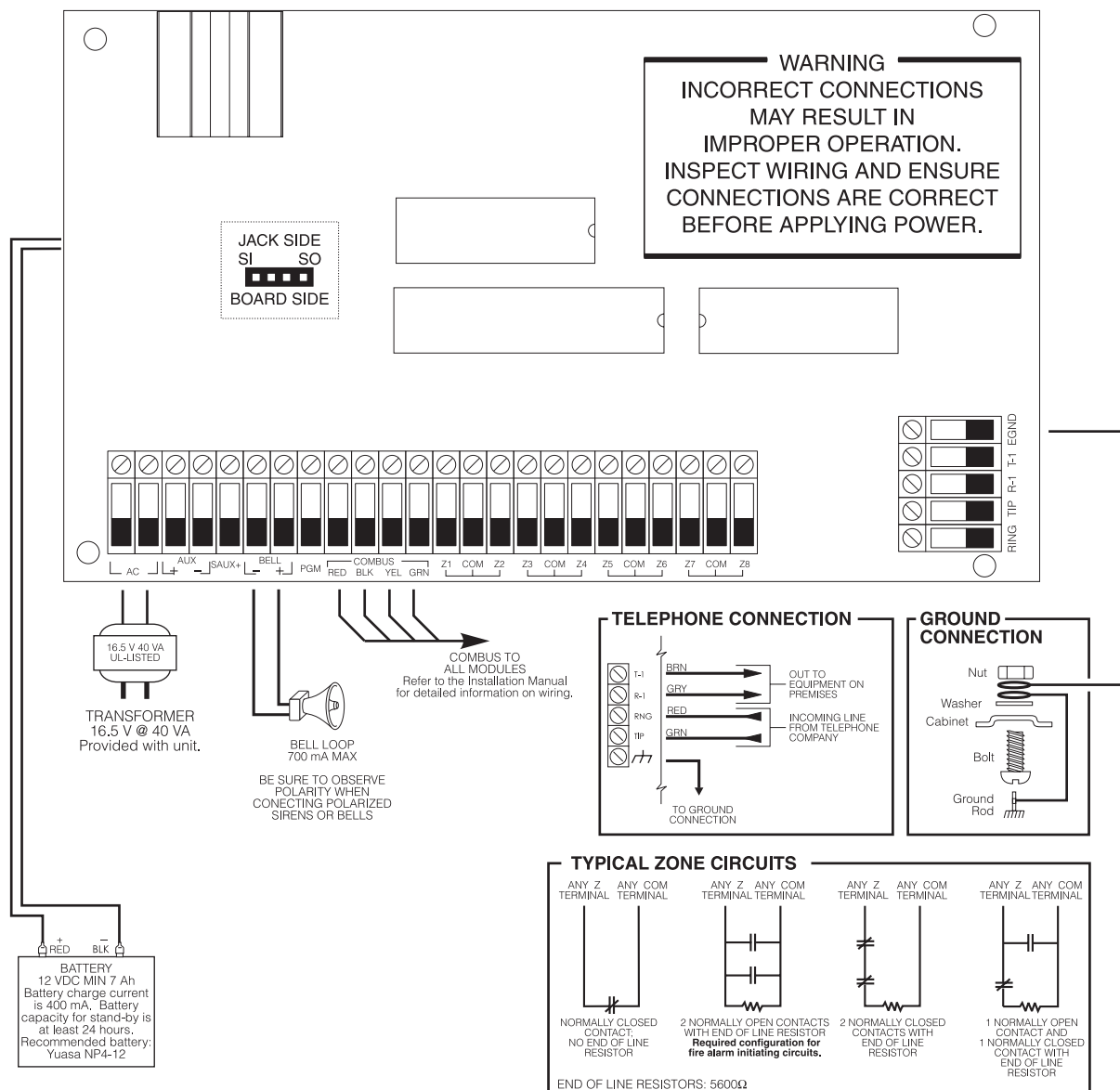

A.2 PC4701 Wiring Diagram (Waterflow and 2-Wire Smoke)

WARNING

Do Not Route Any Wiring Over Circuit Boards.
Maintain At Least 1" (25.4mm) Separations.

All connections to the PC4701 are power limited.
Mount PC4701 on the right or left side-wall of the PC4010CF/PC4020CF cabinet

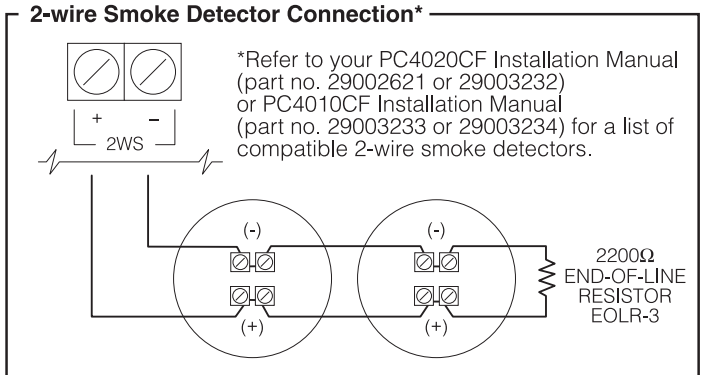
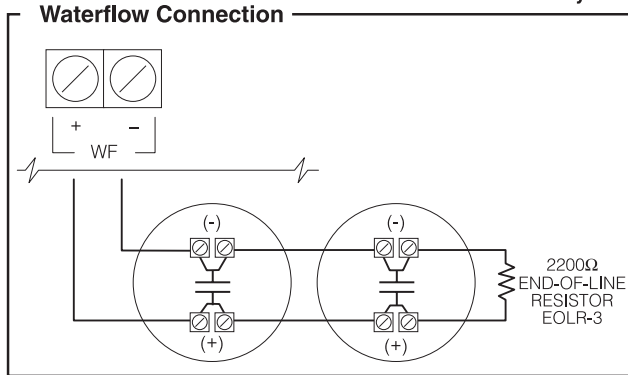
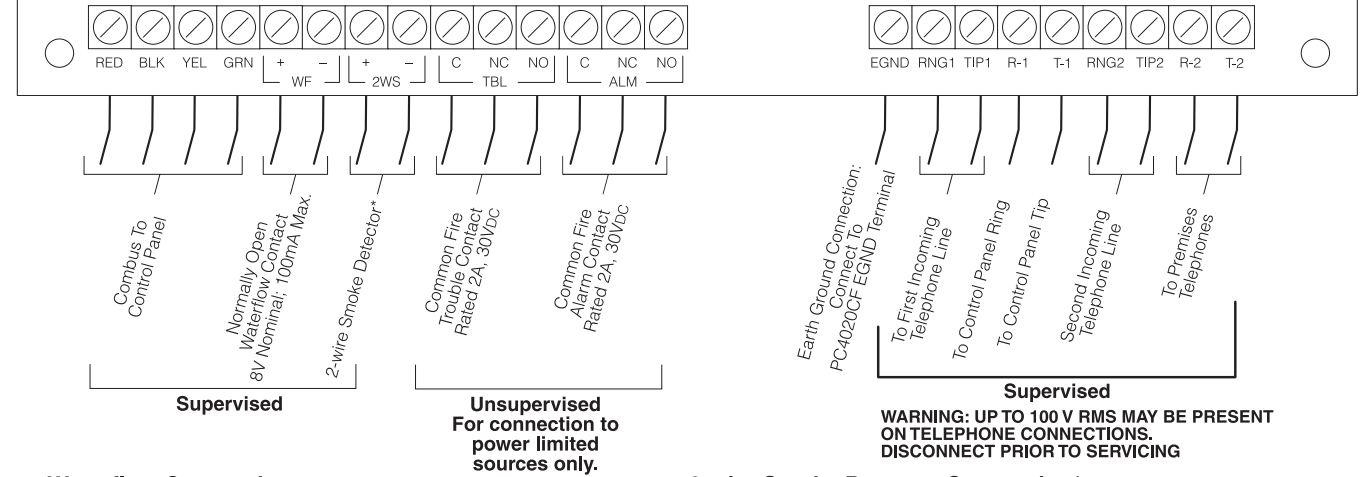

A.3 PC4010CF Communications Connections (LINKS1000, PC4701, LINKS2150, LINKS2450)

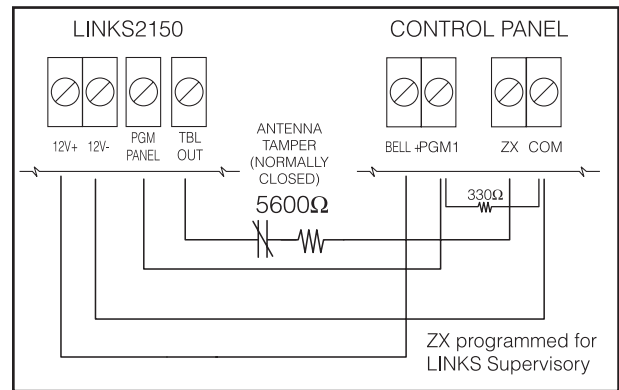
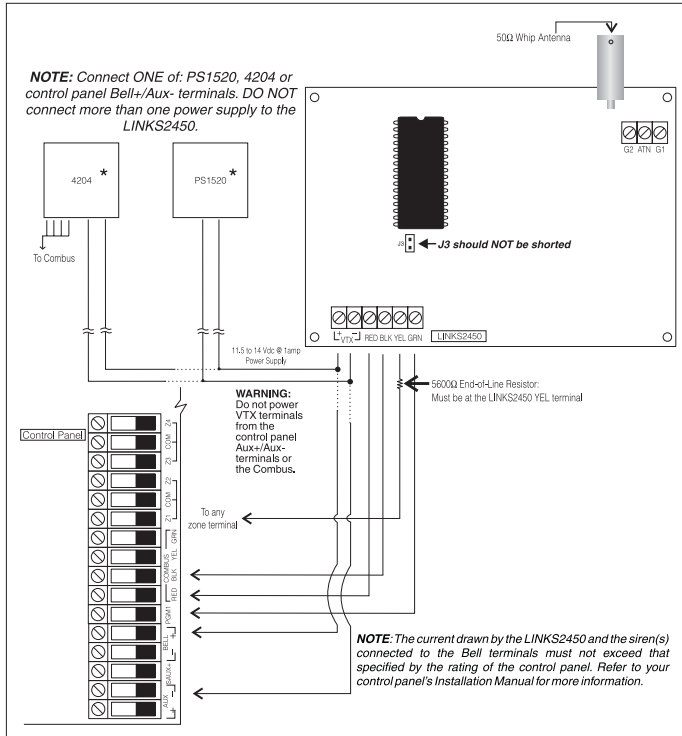
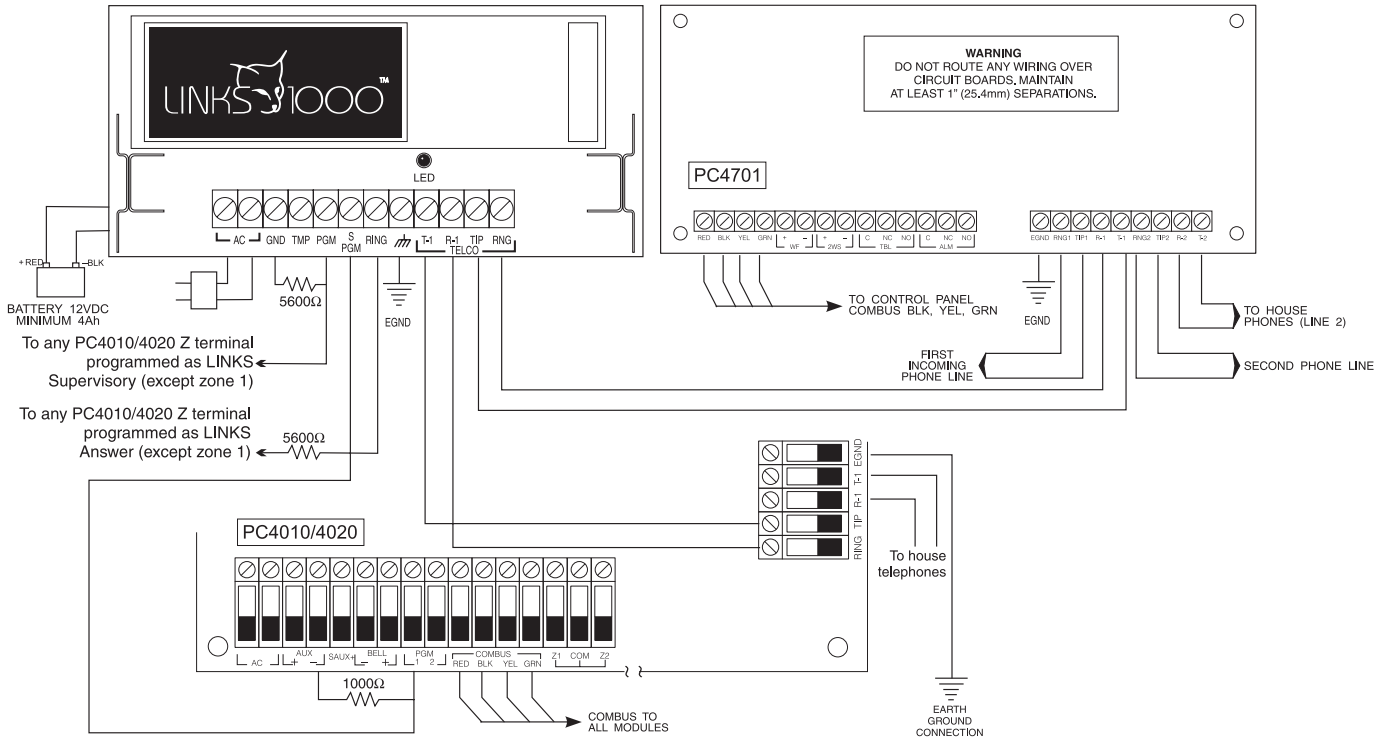

A.4 PC4702BP Wiring Diagram

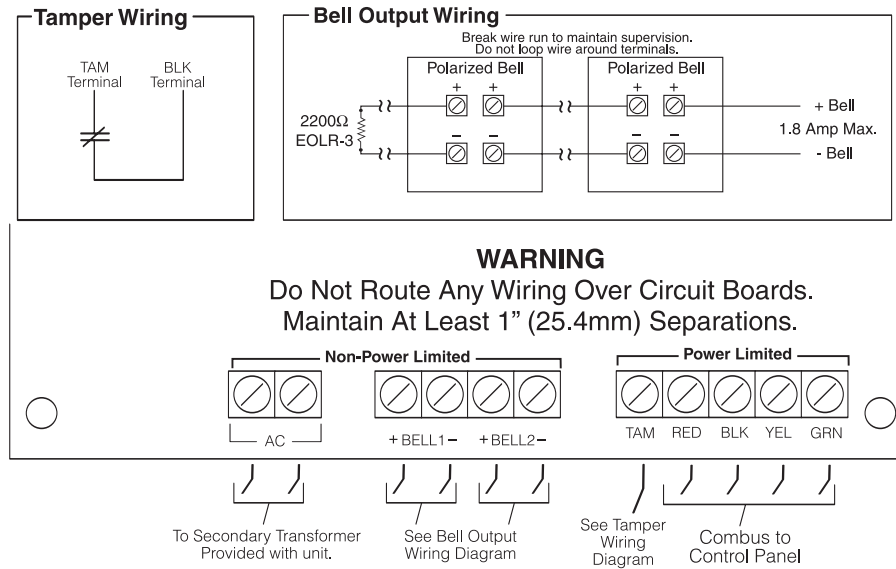

A.5 Battery Lead and AC power Lead Routing for Commercial Fire Systems

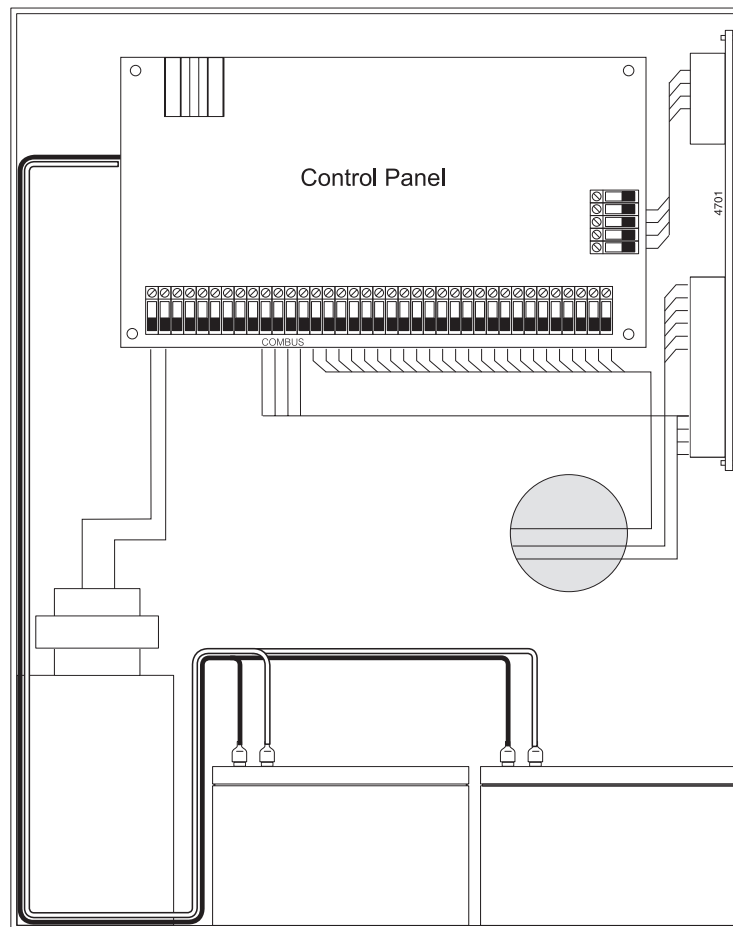

INSTALL BATTERY AND AC WIRING AS SHOWN ABOVE
IMPORTANT: A minimum ¼" (7mm) separation must be maintained at all points between battery/primary AC wiring and all other wiring and connections.

A.6 Sensor Reset for 4-Wire Smoke Detectors

SAUX Connection

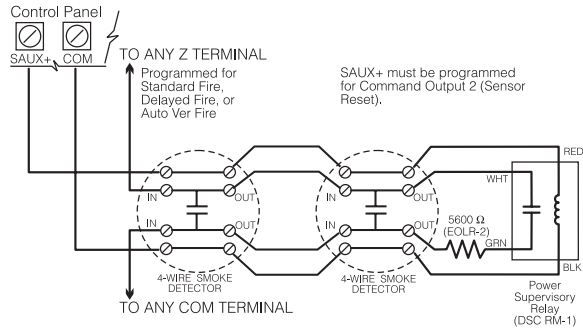

PC4204CF Connection

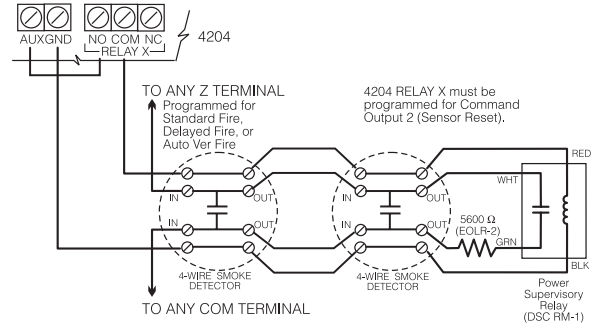

A.7 PGM Connections

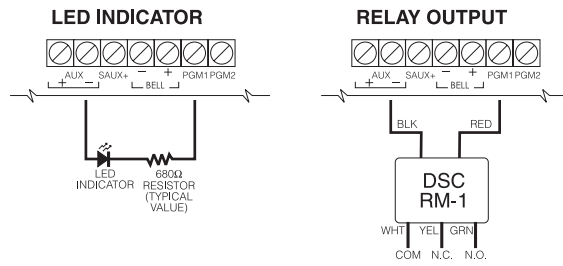

A.8 AMS-220 Addressable Smoke Detector Connection

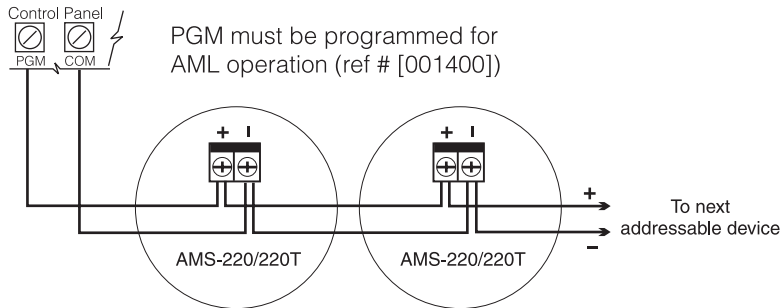

This notice is to be framed and mounted adjacent to the control unit or the keypad at the main entrance.

Fire Alarm Operating Instructions

Normal Stand-by

No audible or visual indicators.

Fire Alarm

Pulsing audible alarm, the following message will be displayed on the keypad:

First Fire Alarm [Zone Label]

This message will be accompanied by other messages related to the alarm. The keypad will scroll through each message at a 2-second interval.

To silence an alarm, enter an Access Code

The alarm messages will be displayed until the initiating devices are mechanically reset.

To Reset Smoke Detectors

Enter an Access Code to reset smoke detectors.

Alarm Test

Activate smoke detector or waterflow sensor according to manufacturer's testing instructions.

Bell and Communicator Test

Enter [*][6][Access Code][4] on a system keypad.

Trouble Conditions

Trouble conditions are indicated by:

- The keypad Trouble light will turn ON
- The keypad buzzer will beep

To view trouble conditions:

- Press [*][2]. The keypad display will indicate the trouble.

To silence the trouble beeps:

- Enter a valid access code at any keypad. The Trouble light remains on and you can view trouble messages using [*][2] until the trouble has been cleared and the affected detectors are reset.

NOTE: *In the event of trouble with the Fire Detection section of this system, contact:*

Name: _____

Address: _____

Telephone: _____

TEST SYSTEM WEEKLY

Refer to Instruction Manual 29003126 for testing instructions.

Index

Numerics

4-Wire Smoke Detector Zones 5

A

AC Delays 10
 transmission 10
AC Trouble 10
Addressable Smoke Detector 5
Alarm
 display 9
 operation 9
Auto Verify Fire 4
Auto-Scroll 9

B

Battery Trouble 10
Bell Cut-off 6, 8
Bell Options 6
Bell Trouble 9
Bypassing Fire Zones 10

D

Delayed Fire Zone 3
Downloading 13

E

External Battery Charger 2

F

Fail To Communicate 10
Fire Drill 10
Fire Inspector Test 11
Fire Silence Delay 6, 8
Fire Supervisory Zone 5
Fire System
 configuration 3, 7
 operation 8
 partitions 3, 7
 reset 8
Fire Timeout 6, 8
Fire Trouble 9
Fire Zone 3
FTC. *See* Fail to Communicate

G

Ground Fault 10

L

Lamp Test 11

O

Outputs
 alarm notification 6
 programming 6

P

PC4701
 zones 5

R

Remote Station Alarm/Trouble Relays 12
Reporting Codes 12

S

Sensor Reset 8
Silence Bells 8
 automatic 8
 manual 8
Silence Fire 9
Smoke Detector Test 11
Specifications 1

T

Test
 addressable smoke detectors 11
 fire inspector 11
 lamp 11
 scheduled smoke detector 11

Trouble

AC 10
battery 10
bell 9
display 9
fail to communicate 10
fire 9
ground fault 10

U

Uploading 13

W

Wiring Diagrams 14
 4-wire smoke 18
 addressable smoke 18
 communications 16
 outputs 18
 PC4701 15
 power 17

Z

Zone
 4-wire smoke 5
 addressable smoke 5
 auto verify 4
 bypassing 10
 delayed 3
 fire supervisory 5
 PC4701 5
 waterflow 4
 waterflow delay 4



©1999 Digital Security Controls Ltd.
1645 Flint Road, Downsview, Ontario, Canada M3J 2J6
(416) 665-8460 • Fax (416) 665-7498 • 1-800-387-3630
www.dscgrp.com
Printed in Canada 29003234 R0