

A decorative graphic consisting of four thick, parallel diagonal lines slanting upwards from left to right, positioned behind the 'Installation Manual' text.

Installation Manual

PC1550

Software Version 4.1
DLS-1 V6.5 and later

• W A R N I N G •

This manual contains information on limitations regarding product use and function and information on the limitations as to liability of the manufacturer.

The entire manual should be carefully read.

TABLE OF CONTENTS

Features	2
Keypad Programmable	2
EEPROM Memory	2
Static/Lightning Protection	2
Supervision	2
Operation	2
Specifications	2
PC1550 Control Panel	2
PC1500RK Keypad	2
Installation	3
Mounting the Panel	3
Mounting the Keypad	3
Auxiliary Power Connection	3
PGM Terminal Connections	3
Bell/Siren Connection	3
Keypad Wiring	3
Fire Zone Wiring	3
Burglary Zone Wiring	3
AC Power Wiring	3
Battery Connection	3
Telephone Line Wiring	3
Wiring Routing for Power & Non-Power Limited	3
Keypad Functions	3
Introduction	3
Master Code	3
2nd Master Code	3
Installer's Programming Code	3
Arming	3
Auto-Bypass/Home-Away Arming	4
Arming Without Entry Delay	4
Disarming	4
Zone Bypassing	4
Trouble Conditions	4
Alarm Memory	4
Downloading Call-Up Command	4
User Programming Commands	5
EEPROM Reset	5
User Function Commands	5
Utility Output Command	5
Installer's Programming Command	6
Arming without Entry Delay	6
Arming For The Night	6
Quick-Exit Command	6
Quick-Arm Command	6
Keypad Zones	6
Programming Guide	6
Introduction	6
Programming	6
Program Data Review	6
Binary Data Display	7
HEX Data Programming	7

Programming Sections	7
[00] Binary Programming	7
[01] 1st Phone Number	7
[02] 1st Account Code	7
[03] 2nd Phone Number	7
[04] 2nd Account Code	7
[05] to [10] Reporting Codes	7
[05] Zone Alarm Reporting Codes	7
[06] Zone Restoral Reporting Codes	8
[07] Closing (Arm ing) Reporting Codes	8
Partial Closing Reporting Code	8
[08] Opening (Disarming) Reporting	8
Codes After Alarm Reporting Code	8
[09] Priority Alarms and Restorals	8
[10] Maintenance Alarms and Restorals	8
[11] Zone Definitions	8
[12] 1st System Option Code	9
[13] 2nd System Option Code	9
[14] 3rd System Option Code	9
[15] Communication Variables	10
[16] Zone Bypass Mask	10
[17] System Times	10
[18] Auxilliary Delay Loop	10
Entry/Exit Times	10
[19] System Clock Times	10
[20] New Installer's Code	10
[21] New Master Code	10
[22] 2nd Master Code	10
[23] Communication Formats	10
[24] Programmable Output Options	11
PGM Terminal	11
[25] Communicator Call Directions	11
[26] Downloading Telephone Number	11
[27] Downloading Access Code	12
[28] Panel Identification Code	12
[29] Number of Rings Before Answering	12
[30] Reset to Factory Default	12
[31] 4th System Option Code	12
[32] 5th System Option Code	12
[33] Answering Machine Double Call Timer	12
[34] 6th System Option Code	12
[35] LINKS1000 Test Reporting Code	12
[36] Keypad Lockout Control	13
[90] Installer's Lockout Enable	13
[91] Installer's Lockout Disable	13
Guidelines for Locating Smoke Detectors	13
For the Record	14
Programming Worksheets	15
PC1550 Control Panel Wiring Diagram	20
UL Listed Residential Installations	Inside back cover

NOTES FOR UL INSTALLATIONS

This equipment is UL listed in accordance with standard UL1023 (Household Burglar - Alarm System Units), standard UL985 (Household Fire Warning Units) and UL1635 (Digital Alarm Communicator System Units).

This equipment has the capability of being programmed for operational features that are not allowed for UL recognized installations. To stay within the standard for household applications, the installer should use the following guidelines when configuring the system.

1. ALL components of the system should be UL listed for the intended application. Note elsewhere in this manual, recommendations for smoke detectors and battery to be used with this equipment.
2. If this system is configured for "Fire", the installer should refer to NFPA Standards #74 for details on locating smoke detectors. When the "Fire" feature is enabled, there must be at least one UL recognized indoor Fire Alarm Warning Signaling Appliance.
3. Maximum allowed entry time = 45 seconds
Maximum allowed exit time = 60 seconds

Minimum allowed bell cutoff time = 4 minutes

4. User bypass must be enabled so that a user code is required to bypass zones.
5. The installer should caution the user to NOT give system information to casual users. Eg. Codes, bypass methods, etc. to babysitters or home service people. Only the "One-Time" use code should be given to the casual user.
6. The installer should advise the user and note in the user manual:
 - Service organization name and telephone number
 - The programmed exit time
 - The programmed entry time
7. Remote programming must be disabled.
8. The Master Code should be changed from the factory default setting and the new Master Code recorded in the User Manual.
9. To achieve 24 hour battery stand-by, the combined AUX and Alarm Load shall not exceed 90mA and 600mA respectively. A 12V 7.0Ah sealed lead-acid battery shall be employed.

Features

Keypad Programmable

The PC1550 is complete with a default program so that it is operational with a minimum of programming. The control panel is completely programmable from the keypad.

EEPROM Memory

The panel uses EEPROM memory which will retain all program information even if AC and battery power are removed from the panel. The EEPROM memory can be reprogrammed thousands of times.

Static/Lightning Protection

The PC1550 has been carefully designed and tested to provide reliable protection against static and lightning induced transients. Our special "Zap-Trac" circuit board design catches high voltage transients right at the wiring terminals, and transient protection devices are placed in all critical areas to further reduce damaging voltages.

Supervision

- Low or disconnected battery
- Loss of AC power
- Loss of time on system clock
- Microprocessor "Watchdog" circuit

Operation

- Download / Upload capability
- Programmable auto downloading
- 60 sec bypass of zones on power up
- Swinger shutdown
- Transmission delay
- Six access codes
- "Master key" code
- Any one of the six zones may be programmed as a fire zone
- Temporal Fire Pattern
- Programmable test transmission
- Zone bypass from the keypad
- Six zones
- Bell / Siren zone
- Programmable output
- Three dedicated keys (Fire/Auxiliary/Panic)
- Backlighting

Specifications

PC1550 Control Panel

- Six fully programmable zones
 - EOL resistor supervised option
 - any one of the six zones may be programmed as a fire zone
 - maximum zone loop resistance: 100 ohms
- Bell / Siren outputs: 1 amp
 - steady for burglary
 - pulsed for fire
- Programmable output: 300 mA
 - 12 programmable options
- Auxiliary power output: 475 mA
- PC1500RK keypad, 3 maximum
- Sealed Battery 11 Vdc, 4 Ah minimum
- Transformer: 16 V_{AC}, 40 VA
- Panel dimensions:
 - 10" high x 8" wide x 3" deep (254 x 208 x 76 mm)
 - Surface mount
- Panel colour: light beige

PC1500RK Keypad

- Three keypad activated zones:
 - Fire, Auxiliary, Panic
- Backlit keys
- 5 system lights:
 - Ready, Armed, Memory, Bypass, Trouble
- 6 zone lights
- Keypad dimensions:
 - 4.5" H x 4.5" W x 0.93" D (114 x 114 x 23.6 mm)
 - Surface mount
- Keypad colour: mist

Installation

Mounting the Panel

Select a dry location close to an unswitched AC source and close to the telephone line connection. Remove the printed circuit board, the mounting hardware and the keypad from the cardboard retainer inside the cabinet. Before attaching the cabinet to the wall, press the four white nylon printed circuit board mounting studs into the cabinet from the back. Once the cabinet is mounted to the wall, pull all the cables into the cabinet and prepare them for connection. Use a meter to test the wiring for opens, shorts and grounds. Press the circuit board onto the white nylon mounting studs. Complete all wiring to the control panel before applying AC power or connecting the battery.

NOTE: See the Control Panel Wiring Diagram on the inside back cover for more information.

Mounting the Keypad

Keypads should be located close to the designated "Entry-Exit" door(s) and mounted at a height convenient for all users.

NOTE: Complete all wiring to the control panel before applying AC power or connecting the battery.

Auxiliary Power Connection

The auxiliary power supply can be used to power keypads, motion detectors and other devices that require 11 Vdc. See the Fire Zone Wiring section for the connection of 4-wire smoke detectors. The total load for the auxiliary power output must be calculated for all devices connected across the AUX +/- terminals and for devices connected between the AUX + and PGM terminals. The output current cannot exceed 475 mA. Allow 35 mA for each PC1500RK keypad connected to the panel.

PGM Terminal Connections

The PGM terminal is a switched negative output which can be controlled by various programming options (See Programming Guide section [24]). Devices controlled by the PGM output must be connected between the PGM terminal, which is (-) and the Aux. (+) terminal.

Bell/Siren Connection

Observe polarity when connecting siren drivers, sirens and polarized bells.

For UL installations, when a bell or siren is used for fire signaling with a pulsed cadence, it must be connected between the AUX+ and BELL- terminals. To maintain bell circuit supervision, do not connect more than one device to the BELL- terminal. A fire bell or siren used for this application must be UL Listed and have a current consumption of 400mA or less (e.g. Wheelock MT-12/24-R).

For UL installations you must use a BSM-100 (Bell Supervision Module) to supervise the Bell circuit.

The following connections of this module refer to BSM-100 Installation Instructions P/N# 29003252.

Input Voltage:
13.85Vdc
Current Standby:
20mA with Buzzer
Active: 70mA

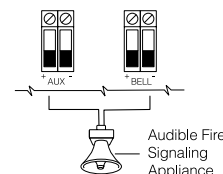

Keypad Wiring

Up to three keypads may be connected in parallel. Do not connect multiple keypads on the same keypad wire run. For Standby Loading purposes, use a current draw of 35 mA per keypad. This represents the panel in the disarmed state with two zones open.

Fire Zone Wiring

Any one of the 6 zones may be programmed as a Fire Loop. See Programming Guide section [11].

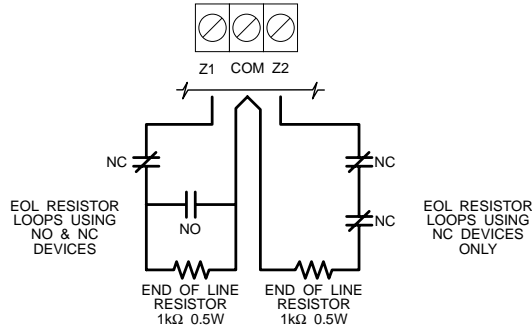

NOTE: For UL installations, zone inputs must be terminated with normally closed initiating devices or end of line resistors (1K Ohm).

Smoke detectors should be the latching type and have N.O. alarm initiating contacts. Power wiring from the AUX + / PGM terminals should be supervised using an RM-1 relay after the last smoke detector. The RM-1 N.O. contacts (closed with power applied) should be wired in series with the alarm initiating end-of-line resistor so that should power to the detector(s) fail, a fire loop trouble will be initiated.

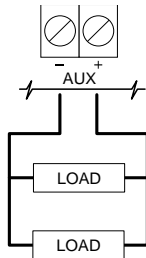

Burglary Zone Wiring

Burglary zone definition, (eg. Delay, Instant, 24 Hr. etc.) is programmed via the keypad. See the Programming Guide, section [11].

AC Power Wiring

Complete all wiring to the control panel before connecting AC power or the battery. Do not plug the transformer into an outlet that is controlled by a switch.

Battery Connection

If the battery is reverse connected, the 3 A PTC will open. The battery charging voltage is factory set and normally needs no adjustment. If the battery charging voltage is out of adjustment, contact your service representative.

NOTE: The battery charging voltage must not be adjusted on UL-listed systems.

If AC power is OFF and the battery voltage is approximately 9.5 V or lower, the battery will be disconnected and the panel will power down. To power up again, the AC will have to be re-established.

Telephone Line Wiring

NOTE: Ensure that plugs and jacks meet the dimension, tolerance and metallic plating requirements of 47 C.F.R. Part 68, Subpart F.

WARNING

FCC restricts using this equipment on certain types of telephone lines. Read FCC Compliance Statement at the end of this manual. Also, do not use this equipment on a telephone line equipped with a "call holding" feature, as the tone generated may interfere with the communicator operations.

NOTE: Do not connect the alarm panel communicator to telephone lines intended for use with facsimile (FAX) machines. These lines may incorporate a voice filter which disconnects the line if other than FAX signals are detected, resulting in incomplete transmissions.

Wire Routing for Power and Non-Power Limited

All wiring entry points are designated by the arrows. All circuits are classified UL installation power limited except for the battery leads which are not power limited.

A minimum 1/4" (7mm) separation must be maintained at all points between power limited and non-power limited wiring and connections.

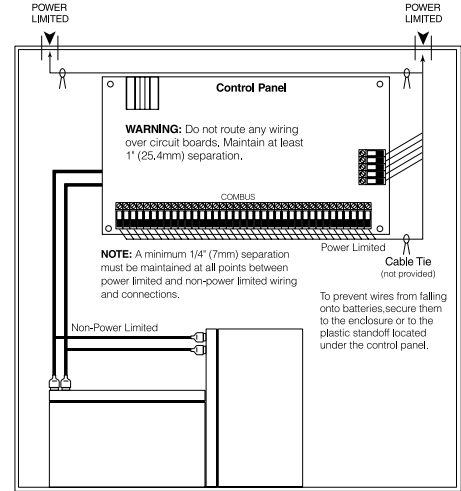

NOTE: Wire entry for power limited wiring must be separated by a different entry access from non-power limited wiring.

Keypad Functions

Introduction

The PC1500RK remote keypad provides complete information and control of the PC1550 control panel. The panel can be fully programmed from the keypad. The 6 zone lights provide alarm and status indication for the alarm circuits. Each zone can be programmed to be a burglary zone or a fire zone.

Master Code

This code is used to arm and disarm the panel, to reset the bells after an alarm, program up to 5 additional codes using [★][5], and to enter other user functions using [★][6]. The panel default program allows the user to change the Master Code. The panel can be programmed, by the installer, so the user cannot change the Master Code. The default Master Code is "1234". See [13] 2nd System Option Code.

2nd Master Code

A second Master Code can be programmed. This code can be changed by the installer only, and is useful where there are multiple panels in a complex. The 2nd Master Code may be used as a "Master Key". The default 2nd Master Code is blank.

Installer's Programming Code

The default Installer's Programming Code is "1500". Using this code and [★][8], the installer can gain access to the system to enter panel program information. This code can be changed by the installer.

Arming

Before arming the panel, close all protected doors and windows and stop movement in areas covered by motion detectors. If the "Trouble" light is on, check for the type of trouble ([★][2]) and correct the fault condition. If the "Bypass" light is on, insure that the zones bypassed are bypassed intentionally, ([★][1]). If the "Ready" light is not on, one or more zones are open. The system can only be armed when the "Ready" light is ON. To arm, enter a 4 digit access code. As each digit is entered, the keypad sounder will beep. When the correct access code has been entered the "Armed" light will come ON and the keypad will beep 6 times. If the access code has been entered incorrectly, the keypad will sound one long tone. Press the [#] key and enter the access code again.

Once the panel has been armed, exit through the designated entry/exit door before the exit delay time expires. At the end of the allowed exit time, all lights on the keypad will go out except the "Armed" light. The

“Bypass” light will be ON if a zone is bypassed and if Show Bypassed Status While Armed is programmed in section [31], zone light 4 ON.

See [17] System Times for instructions on changing the Exit Delay time.

Auto-Bypass/Home-Away Arming

Interior zones can be programmed as Home-Away zones (section [11]). This means that when a correct access code is entered, and you **do not** exit the premises, the system will, at the end of the exit delay time, arm with interior zones automatically bypassed if those interior zones have been programmed as “Home-Away” zones. The “Bypass” light will come ON. This is a convenience feature for the user who wishes to remain at home with the system armed.

To reactivate the interior zones that have been automatically bypassed, press [★][1]. The “Bypass” light will go out. If the bypassed zones were programmed as Home-Away with delay, the “Bypass” light will go out after the delay. This command is a quick method of fully arming the system before going to bed and is useful for the user who has a keypad outside areas protected by interior zones.

Arming Without Entry Delay

To eliminate the Entry Delay, arm the system using [★][9] [access code]. An exit may be made as in normal arming. The system will arm as described above in Auto-Bypass / Home-Away arming whether an exit is made or not. The “Armed” light will flash to indicate that the system is armed without the entry delay.

Disarming

Enter the premises through the designated entry-exit door. The keypad sounder will be on as a reminder to disarm the system. Go to the keypad and enter a valid access code. If an error is made entering the code, press [#] and enter the correct code. The “Armed” light will go out and the sounder will stop. The correct access code must be entered before the entry time expires or the panel will go into alarm. To change the entry time see section [17] System Times.

If an alarm occurred while the panel was armed, upon disarming the “Memory” light and the zone light(s) of the zone(s) that caused the alarm will flash for two minutes. Pressing [#] will stop the flashing, extinguish the zone light(s) and return the panel to the ready mode. The “Memory” light will stay on steady to indicate that an alarm did occur during the last armed period. To view the zone(s) that caused the alarm, see Alarm Memory Display [★][3].

Zone Bypassing

[★]+[1]

A bypassed zone will not be armed and will not sound an alarm. Use zone bypassing when access is needed to part of a protected area or if damage to contacts or wiring cannot be repaired immediately. The panel can be armed with one or more zones bypassed even if the zone(s) are open. The “Ready” light will be ON and the “Bypass” light will be ON if a zone is bypassed. A fire zone **cannot** be bypassed.

Zone bypasses are automatically cancelled when the panel is disarmed.

NOTE: Any zone defined as 24 Hour Bell, 24 Hour Bell/Buzzer, or 24 Hour Buzzer can not be bypassed while that zone is violated. To bypass a 24 Hour zone, the zone must be physically restored.

To Bypass Zones:

Enter [★][1] - the “Bypass” light will start flashing.

Enter [zone number to be bypassed]; the zone light will come ON to indicate that the zone is bypassed. To remove a bypass, enter the zone number and the zone light will go OFF. Continue entering the zone numbers for the zones you want bypassed. Press [#] to return to Ready.

To Recall Bypassed Zones:

Enter [★][1][9]

This command will recall the last zone or group of zones that were bypassed. This feature is useful if the same group of zones is bypassed regularly.

Bypass Disable:

The installer can program the panel to prevent the user from being able to

bypass certain zones. Lights for these zones will not come ON in response to the bypass command. See Zone Bypass Mask (section [16]).

Trouble Conditions

[★]+[2]

The PC1550 continuously monitors a number of trouble conditions. If one of these conditions occurs, the keypad “Trouble” light will come ON and the buzzer will sound two short beeps every 10 seconds. To silence the buzzer, press [#]. The buzzer will stop but the “Trouble” light will remain ON until the trouble condition is cleared. See section [10] Maintenance Alarms and Restorals for a list of codes that can be transmitted to the monitoring station.

To view the trouble condition, press [★][2].

- 1. Low Battery.** If the battery voltage is low, the battery is disconnected or the battery PTC is open, a trouble will be displayed and can be reported.
- 2. AC Failure.** On loss of AC power, the “Trouble” light will come ON immediately, but the keypad buzzer will not sound. The keypad buzzer will sound if AC power remains off and the battery reaches a low voltage. The delay before transmitting AC Fail can be programmed from 1 to 255 minutes. See Programming Section [17].
- 3. PTC Failure - Bell / Siren or AUX Output.** A trouble is displayed if the Bell / Siren PTC is open. If the AUX output PTC fails, it will not be displayed but will be transmitted if programmed to do so.
- 4. Unsuccessful Communication Attempt** If the digital communicator is unsuccessful at communicating with the monitoring station after 8 attempts at each phone number that is tried, a trouble is generated. See section [15], Communication Variables. If a later attempt at communication is successful, the trouble is cleared. The trouble can also be cleared by pressing [#] to exit from the trouble view mode.
- 5. Fire Alarm Circuit Trouble** An open circuit on the zone programmed as a fire loop will initiate a trouble. See Zone Definitions section [11].
- 6. Loss of Time on System Clock** When the PC1550 is powered up or reset, the internal time of day clock needs to be reset to the correct time. The trouble will be cleared after entering the trouble view mode and pressing [#] to exit. The trouble will also be cleared on any attempt to set the time of day. See [★][6] User Function Command for setting the clock. Press [#] to return to Ready. **NOTE:** A trouble will not be generated if both the test transmission and Auto-Arm times are not programmed with valid times.

NOTE: If [9] is pressed while in the trouble display mode, the most recent trouble will be displayed on the zone lights. This trouble memory is most useful as a diagnostic tool when installing and servicing the PC1550. Press [#] to return to “Ready”.

Alarm Memory

[★]+[3]

Alarms caused during the previous armed period are stored in memory. To view these alarms, press [★] [3]. The “Memory” light will flash and the alarm(s) will be displayed on the flashing zone lights.

In addition to the last alarm memory, there are two history levels. After entering the memory mode, pressing any key [0] to [9] will display the two other levels of alarm history. Each time a key is pressed, the keypad will beep 1, 2 or 3 times to indicate which level of history is being viewed.

When the panel is armed, and if there is an alarm in the 1st level, the 1st level is cleared and the contents moved to the 2nd level. The 2nd level contents are moved to the 3rd level and the 3rd level contents are discarded. The “Memory” light will be ON only if there was an alarm during the previous armed period. Press [#] to return to Ready.

Downloading Call-Up Command

[★]+[4]

This command is used to initiate a call to the downloading computer so that the panel can be accessed by the computer. This command must be enabled in section [14], option [2]. Sections [26], [27] and [28] must

be programmed with the downloading computer's telephone number, the downloading access code and the panel identification code.

NOTE: [★][4] command can be programmed to require an access code (e.g. [★][4][access code]) in section [14], option [4].

User Programming Commands

[★][5]

Pressing [★][5] allows the user to program access codes 2 through 6. The 1st access code is the Master Code, which the installer may choose not to allow the user to program (Section [13] Option [2]). The 6th code may be changed from a regular code into a "one-time" use or "Maid's Code". See section [13] option [5].

NOTE: The One-time Use code is only cleared when it is used to arm. If the Quick-Arm command [★][0] is used to arm, the "one-time" code will **not** be erased.

Programming Access Codes:

Enter [★][5][Master Code] to enter the access code programming mode. The "Memory", "Bypass" and "Trouble" lights will begin to flash. The zone lights are used to indicate the program status of the 6 access codes.

Zone Light	Access Code Status
OFF	Code not programmed
Steady	Code programmed
Flashing	Code being programmed

Upon entering this programming mode, the 1st zone light will be ON to indicate that the Master Code is programmed with the Factory Default Code ("1234"). The Master Code may be changed here if the user has been enabled to change the master code, or in section [21] by the installer.

Changing or Adding a Code

To change access codes 1 to 6, press the corresponding key (1 to 6). The corresponding zone light will begin to flash. Enter the new four digit number. Do not use the [★] key or [#] key when entering the four digit number. After the four digits are entered, the keypad will beep 3 times and the zone light will come on steady. If you are changing an existing code, the new code will replace the old one. If you wish to program another code, press the number key for the code to be programmed and enter the new 4-digit code. Press [#] to exit.

Erasing a Code

To erase a code, enter [★][5][Master Code]. Press the key of the code you wish to erase. The zone light for that code number will flash. Enter [★][★][★][★].

NOTE: The Master Code cannot be erased. If the Master Code is forgotten and the panel is left disarmed, program a new Master Code using the [★][8][Installer's Code][21] command or use the 2nd Master Code to reprogram the Master Code.

EEPROM Reset

If the Master Code is forgotten and the panel is armed, see Programming Section [30] for the hardware method of resetting the panel to the factory default condition. A software reset to factory defaults cannot be performed if the panel is armed. Reset is not necessary if the 2nd Master Code is programmed.

User Function Commands

[★][6]+[Master Code]

This function is used to set the System Clock time and to set the Auto-Arm time as well as toggle a number of system functions. As soon as the command is entered, the "Memory", "Bypass" and "Trouble" lights begin to flash.

Enter [★][6][Master Code][Number from list below].

Items [4], [5], [6] and [0] turn ON and OFF various features. When the item key is pressed and the feature is being turned ON, the keypad sounder will beep 3 times. If the feature is being turned OFF the sounder will give one long beep. Pressing item [8] gives a 2-second Bell / Siren and Keypad Light and Buzzer test.

[1] Setting the Clock

The System Clock is a 24 Hr. clock and times must be entered as 2-digit numbers.

e.g. HH - 01, 02, 10, 11, 23, 24
MM - 01, 02, 35, 36, 58, 59
8:05 AM would be entered as 0805
1:30 PM would be entered as 1330

Setting the system 24 Hr. clock tells the system the time of day. If the system is without power, (AC and battery), it cannot continue to keep time. When the panel is powered up, the system clock must be reset. If the time needs to be reset, then a trouble #6 will be indicated on the keypad. (See [★][2] System Trouble Display). Trouble #6 will not be generated if the Test Transmission and Auto-Arm times are not programmed with valid times. (9999 in these positions disables these features - see Section [19]).

[2] Set Auto-Arm Time

The PC1550 can be programmed to arm at the same time each day. At the selected Auto-Arm time, the bell will sound one short burst every 10 seconds for a one minute period if section [32] option [2] is off. The keypad will also sound for one minute. If any key is pressed during the 1 minute warning period, Auto-Arming will be aborted. Auto-Arming will be attempted at the same time the next day. To set the Auto-Arm time, enter [★][6][Master Code][2] then enter the hours and minutes as described at the beginning of this section. This feature must also be enabled (see item [5] below).

[3] For Future Use

[4] Quick-Arm

Pressing [4] while in the User Function Command mode will Enable (3 beeps) or Disable (one long beep) the Quick-Arm feature. With this feature enabled, the panel can be armed by simply entering [★][0].

[5] Auto-Arm

With this feature enabled, the panel will automatically arm at the same time each day. The time is set in section [19] or [★][6][Master Code][2].

[6] Door Chime

With this feature enabled, the keypad will beep 5 times when any zone defined as delay, instant or auxiliary delay opens or closes. The Door Chime feature does not operate on other zone definitions. Zone Bypass may be used to eliminate beeping on zones where it is not wanted. The Door Chime feature functions only while the panel is in the Disarmed mode.

[8] Bell Test

Pressing [8] while in the User Function Command mode will sound the bell/siren, the keypad sounder and turn on all the keypad lights for 2 seconds.

[9] For Future Use

[0] Installer's Test

This feature facilitates final testing of the system and when enabled, the bell/siren will operate for 2 seconds each time a zone is put into alarm. Each zone should be tripped individually to avoid confusion about which zone originates the alarm. To exit the Installer's Test mode, arm then disarm the panel.

NOTE: The communicator will transmit all alarms and restorals. Disable the communicator if this is not desired (section [12], option [1]).

Utility Output Command

[★][7] or [★][7]+[Access Code]

The Programmable Output (PGM terminal) can be programmed for activation by a keypad command. This output can be used to operate other devices such as door openers, special lighting, door strikes or to reset smoke detectors. (Section [24], item 2, 3 or 4.) Depending on the option chosen, the [★][7] command may or may not require a subsequent access code.

When the correct command is entered, the keypad sounder and the PGM output will operate for 5 seconds.

Installer's Programming Command

[★]+[8]+[Installer's Code]

The PC1550 is completely programmed from the keypad by using commands in the [★][8] section. See the Programming Section of this manual. The default Installer's Code is [1500].

Arming without Entry Delay

[★]+[9]+[Access Code]

Entering [★][9] before the arming code will arm the panel without the entry delay on delay zones. Also "Home-Away" zones are automatically bypassed. When armed using the [★][9] command, the "Armed" light will flash to remind the user that the system is armed without entry delay. This command allows the user to remain at home and have an instant alarm on the entry doors.

Arming For The Night

[★]+[1]

To reactivate "Home-Away" zones that have been bypassed by arming with the [★][9] command, enter [★][1]. When this command is entered, the "Armed" light will continue to flash to remind the user that the Entry Delay is not applied to the Delay Zones. Also, the "Bypass" light will be shut OFF to indicate that the Home-Away zones are no longer bypassed. Note that the [★][1] command will not remove bypasses from zones that have been manually bypassed.

Quick-Exit Command

[★]+[0] when Armed

Entering [★][0] when the system is armed will allow the user to exit the premises through any delay zone without altering the status of the system if the Quick-Exit feature is enabled (section [32], option [4]). For 2 minutes after [★][0] is entered into an armed system, one and only one delay loop may be tripped. Any additional activity on any other active loop will cause that loop to begin its alarm sequence.

Quick-Arm Command

[★]+[0]

Entering [★][0] is accepted as a valid arming code if the Quick-Arm feature is enabled. This command is often used when individuals are required to arm the system but not disarm the system. This could be used with home visitors in the case of a residential alarm system or for junior employees and maintenance staff in the case of commercial systems. See [★][6] User Functions Command section, for enabling and disabling the Quick-Arm feature.

Keypad Zones

[F] - [A] - [P]

There are three zones which can be activated with single key entries on the keypad. For the [F], [A] and [P] keys to be functional for transmission, they must be enabled by the installer in Alarm and Restoral Codes, section [09].

[F]ire Key Pressing the [F] key and holding it for 1 second will initiate a local alarm which will sound using the Temporal Fire Pattern or will pulse the bell. Also if programmed, it will transmit the alarm to the monitoring station. The keypad will sound a series of short beeps once the panel has accepted the alarm.

[A]uxiliary Key Pressing the [A] key and holding it for 1 second will, if programmed, transmit an Auxiliary alarm to the monitoring station. There is no local alarm and no keypad lights will come ON when this key function is activated. The keypad will sound a series of short beeps upon successful completion of the transmission to the monitoring station.

[P]anic Key Pressing the [P] key and holding it for 1 second will, if programmed, send a transmission to the monitoring station. The alarm signal can be programmed to be *audible* or *silent*. See Programming Section [12], option [6]. If programmed as *audible*, the local bell / siren will sound steadily.

Keypad audible annunciation for the [P] key is programmable, Section [14], option[5], for feedback (3 beeps) or silent (no buzzer feedback). If programmed for *audible*, the buzzer will sound once the key input is accepted.

Programming Guide

Introduction

The essential information which defines the operation of the control panel is stored in a section of the EEPROM memory which is accessible using the Installer's Programming code or via downloading. If the Installer's code is forgotten, the EEPROM may be reset to the factory default code. See Section [30], Reset to Factory Default.

Programming

With the panel in the disarmed mode, enter [★][8][1500]. The panel can only be programmed while it is in disarmed mode. The default installer's code is 1500; it can be changed in section [20], New Installer's Code.

Once the installer's command is entered, the "Armed" light will come ON steadily and the "Memory", "Bypass" and "Trouble" lights will flash. This indicates that the panel is ready for programming.

NOTE: *If no key entry is made for 2 minutes, the panel will return to the Ready mode and installers programming will have to be re-entered.*

With the "Armed" light ON steadily, enter 2 digits for the section you wish to program. Section numbers range from [01] to [36], and each section can be programmed independently. Section [00] is reserved for binary programming which is normally done on instruction from factory technical personnel.

Once the 2 digits for the section you wish to program are entered, the "Armed" light will go OFF, the "Ready" light will go ON steadily, and the keypad sounder will beep 3 times. The keypad is now ready to accept data for the selected section.

Most sections contain groups of 2-digit entries and the keypad buzzer will beep twice after each 2-digit group is entered. When the section is first entered, the first 4 zone lights will indicate, in a binary format, the value of the first digit in that section (see binary display section on this page). If you wish to change that digit, simply enter the new digit from the keypad. If you wish to keep that digit unchanged, you can enter the same number or skip the digit by pressing the [F] key. Once the first digit has been entered or skipped, the 4 zone lights will display the value of the second digit. After each digit is entered or skipped, the zone lights show the value of the next digit in the binary format.

When the required data for the section being programmed is completely entered, the keypad sounder will beep several times and the "Armed" light will come ON to indicate that the expected data has been entered. At this point, you will still be in the program mode and need only enter the section number for the next section you wish to program.

It is not necessary to program all 2-digit pairs in any given section. A section can be entered and selectively programmed by going only to the digit(s) you wish to change and then pressing [#] to return to the programming mode. For 2-digit pairs, both digits must be programmed before pressing [#]. Only the data entered before pressing [#] will be changed in the EEPROM.

Program Data Review

- Enter the section you wish to program by entering the 2-digit section number.
- The first 4 zone LEDs will represent the value, in binary format, of the first digit in that section.
- Each press of the [F] key will advance the display to the next digit.
- At the end of the section, the keypad will beep several times and then return to the program mode so that another section can be selected for review or programming.

NOTE: *Only sections [01] through [24] and [26] through [28] can be reviewed using the method described above. Section [25] cannot be reviewed.*

Sections [12], [13], [14], [16], [31], [32], [34]

These sections use the zone lights to indicate which functions are active and which number key to press to turn them ON and OFF. When one of these sections is entered, zone lights 1 to 6 will display which functions are currently ON. Pressing the key number corresponding to the zone light number will toggle the function ON and OFF; the zone light will turn ON or OFF to indicate the state of the function. All functions

can be turned OFF at once by pressing [0]. When the correct selections have been made, press [#] to save the selections in memory and return to the program mode.

Binary Data Display

Zone lights 1 through 4 are used to display the value, in binary format, of the data as shown in the table below.

HEX Data Programming

Certain programming entries may require the entry of data in HEX (hexadecimal, or base 16) format. HEX numbering uses the digits 0 through 9 and the letters A through F.

The letters A through F are represented by the number keys 1 through 6. To enter data in HEX format, first press [★]. The "Ready" light will flash. Enter the HEX value, then press [★] again to return to the normal entry mode. The "Ready" light will stop flashing.

To enter HEX numbers:

- | | | | | | |
|---|---------|-----------|---|---------|-----------|
| A | ▶ Enter | [★][1][★] | D | ▶ Enter | [★][4][★] |
| B | ▶ Enter | [★][2][★] | E | ▶ Enter | [★][5][★] |
| C | ▶ Enter | [★][3][★] | F | ▶ Enter | [★][6][★] |

Enter [★] **before** and **after** each digit. The last digit in each section does not require the final asterisk ([★]) to be entered.

Programming Sections

[00] Binary Programming

This section is normally used upon instruction from factory technical personnel for specialized programming not covered by the standard programming instructions.

[01] 1st Phone Number

This is the first telephone number the Communicator will dial. See Section [25], Communicator Call Direction.

After entering section [01] for programming, enter the telephone number the same way you would dial it on a touch-tone phone. Press [#] after the last digit to complete the telephone number programming. A second dial tone search, as required in a PBX system, can be added by programming a HEX 'D' between the digits in the phone number where it is required. To enter a HEX 'D', press [★] [4] [★].

Instead of a dial tone search, a pause of 4 seconds can be inserted between digits in a telephone number.

Enter [★, 2, ★] to dial a '★' (HEX 'B')

Enter [★, 3, ★] for a 4-second pause (HEX 'C')

The total number of digits, including dial tone searches and pauses, must not exceed 16. Remember, press [#] to complete entry of the telephone number. When complete, enter two digits to program another section.

[02] 1st Account Code

The 1st Account Code is always transmitted to the 1st telephone number to identify the customer. Enter a 4-digit number. If the HEX digits 'A' to 'F' are required, remember to enter [★] before and after the digit entry.

Where a zero is required in the account code, enter HEX 'A' (★, 1, ★) to transmit 10 pulses which will be interpreted as a zero by the monitoring station receiver.

If a 3-digit code is required, as in 3/1 formats, enter [0] as the LAST digit. The [0] represents a null digit where no pulses are transmitted.

[03] 2nd Phone Number

This is the second telephone number to which the communicator will dial. See [01] for programming instructions.

[04] 2nd Account Code

The second account code is always transmitted to the 2nd telephone number. See [02] for programming instructions.

[05] to [10] Reporting Codes

These sections are used to program the communicator reporting codes. A reporting code is transmitted along with the account code with each transmission. If the reporting codes are not programmed, no

transmission will be sent when an event takes place (i.e. alarm, restoral, opening / closing, trouble, etc.). To prevent a transmission from being sent for any event in the following sections, leave it unprogrammed or enter [00] as the reporting code.

Section [05] and [06] each have 6 reporting codes. Sections [07], [08] and [10] each have 7 reporting codes, while section [09] has 8 reporting codes. Once a section is entered, the system expects a series of 2-digit numbers to be entered. The keypad beeps twice and the "Armed" light flashes after each 2-digit entry. After the last 2-digit number is entered, programming of the current section is complete.

Value	Hex Data Entry*															
	0	1	2	3	4	5	6	7	8	9	A	B	C	D	E	F
Zone 1	□	■	□	■	□	■	□	■	□	■	□	■	□	■	□	■
Zone 2	□	□	■	■	□	□	■	■	□	□	■	■	□	□	■	■
Zone 3	□	□	□	□	■	■	■	■	□	□	□	■	■	■	■	■
Zone 4	□	□	□	□	□	□	□	□	■	■	■	■	■	■	■	■

■ Light On
 □ Light Off
 * See Hex Data Entry instructions

The keypad gives a series of beeps, the "Ready" light goes OFF and the "Armed" light comes ON. The keypad is then ready to accept the next 2-digit section number for programming.

When changing reporting codes in a section, you can scroll to the code you wish to change by pressing the [F] key. Only codes actually changed will be altered in the EEPROM. Press [#] to exit from the programming sequence.

[05] Zone Alarm Reporting Codes

Once Section [05] is entered, the panel expects 6 2-digit numbers for the Alarm Reporting Codes for zones 1 to 6. These codes are used by the communicator when there has been an alarm on zones 1 to 6.

Listed below are several programming examples and the resulting transmission using different formats for the reporting codes. Obtaining different formats requires entering data in the Account Code Section [02] or [04], the Reporting Code Sections [05] to [10], and the Communicator Format Section [23].

3/1 FORMAT - Non-extended reporting requires:

- 3-digit account code in sections [02] or [04].
i.e. Enter 1230 for account code 123
- Format Code [0], [1], [2], [3], [4] depending on receiver type in section [23].
- Single line digit Alarm Reporting Code Section [05]
i.e. Enter [30] for single digit code 3 (0 = no pulses)

TRANSMISSION SENT: 123 3

4/2 FORMAT - Non-extended reporting requires:

- 4-digit account code in sections [02] or [04].
i.e. Enter 1234 for account code 1234
- Format Code [0], [1], [2], [3], [4] depending on receiver type in section [23].
- 2-digit Alarm Reporting Code in section [05]
i.e. Enter [31] for 2-digit code 31

TRANSMISSION SENT: 1234 31

3/1 FORMAT - Extended reporting requires:

- 3-digit Account Code in section [02] or [04]
i.e. Enter 1230 for code 123
- Format Code [8], [9], [A], [B], [C] depending on receiver type in section [23]
- 2-digit Alarm Reporting Code in section [05]
i.e. Enter [31] for 2-digit code 31

TRANSMISSION SENT: 1st ROUND 123 3
2nd ROUND 333 1

If a transmission is not wanted for a particular reporting code, then enter '00' or 'FF' to disable that reporting code.

[06] Zone Restoral Reporting Codes

These reporting codes are used by the communicator to transmit zone restorals for zones 1 through 6. Use instructions in section [05] above as a guide for programming.

[07] Closing (Arming) Reporting Codes Partial Closing Reporting Code

Reporting codes 1 to 6 are used to identify closings for access codes 1 to 6. If partial closing is identified in section [14], then alarm codes for manually bypassed zones will be transmitted when the system is closed with one or more zones bypassed.

When transmitting in 4/2, 3/1 or any other of the extended formats, see section [05] above. The 6 closing codes are programmed as follows:

[C1], [C2], [C3], [C4], [C5], [C6]

Where the first digit HEX 'C' represents a closing signal and the second digit represents the user access code which was used to arm the system (HEX 'C' could be any other number depending on what is used at the monitoring station).

The closing code transmission takes place after the exit delay time. Therefore, if the system is armed and disarmed before the expiry of the exit time, no closing transmission will take place.

The partial closing code, if used, is transmitted in tandem with the regular closing code to identify the closing as a partial closing.

When the system has been armed using the Quick-Arm command [★][0] or using the Auto-Arm feature, access code #1 will be transmitted.

[08] Opening (Disarming) Reporting Codes After Alarm Reporting Code

The first 6 reporting codes correspond to the 6 user access codes. When the system is disarmed using one of the access codes, the corresponding reporting code in this section is transmitted. See section [07] above for examples of reporting code programming.

If the After Alarm Code is programmed, that code will be transmitted to the monitoring station on opening if an alarm occurred during previous armed period. This feature is useful for installations where openings and closings are not reported normally, but it is desired to have a report to the monitoring station on opening if an alarm did occur during the previous armed period. This feature allows the monitoring station to know when the user is on the premises and available to receive a report about alarms while the system was closed.

[09] Priority Alarms and Restorals

These reporting codes are used by the communicator to transmit the following list of troubles, alarms and restorals. See section [05] as a guide for programming.

- Fire loop trouble.
- Fire loop trouble restore.
- Keypad [P]anic alarm.
- Keypad [P]anic restore.
- Keypad [F]ire alarm.
- Keypad [F]ire restore.
- Keypad [A]uxiliary alarm.
- Keypad [A]uxiliary restore.

Transmission for operation of the [F], [A] and [P] keys will only take place if the appropriate sections in [09] are programmed with a reporting code.

[10] Maintenance Alarms and Restorals

These reporting codes are used by the communicator to transmit the following list of alarms and restorals. See section [05] as a guide to programming.

- Low battery alarm.
- Low battery restore.
- AC failure alarm.
- AC failure restore.
- PTC failure alarm.
- PTC failure restore.
- Automatic Test Code

Test code is not transmitted if periodic downloading is selected, section [14], light 3. For Automatic Test Code Reporting, the time between reports (in days) must be entered in section [17] and the time

of day for the report must be entered in section [19].

NOTE: For UL installations, either AC failure or battery trouble reporting must be enabled.

[11] Zone Definitions

As in the reporting codes sections, once this section is entered, 6 2-digit numbers are required. Each 2-digit number entered defines how a zone will operate.

Zone Definitions Digit #1

The first digit determines whether the zone will cause a silent alarm or an audible alarm and whether the zone response will be fast or slow. Loop response time can be programmed in section [17] and can be set from 10ms to 2550ms. The factory default loop response time is 500 ms. If set at fast, the loop response time is 10 ms, and if set at slow, the loop response time is 500 ms or whatever time is set in section [17].

Digit # 1 Summary

- [0] = slow & audible
- [1] = slow & silent
- [2] = fast & audible
- [3] = fast & silent

Zone Definitions Digit #2

Digit #2 determines the zone type, [0] through [8], as described below.

[0] Standard Delay Loop has an entry and exit delay and is normally used for entry/exit doors. The exit delay starts as soon as the panel is armed. The loop may be opened and closed during the delay time without causing an alarm. After the exit delay time has expired, opening the loop will start the entry delay timer. During the entry delay time, the keypad buzzer will sound steadily to advise the user that the system should be disarmed. If the panel is disarmed before the entry time expires, no alarm will be generated.

The default times for this type of loop are a 30 second entry delay and a 120 second exit delay. The entry and exit delays may be independently programmed in section [17] for periods from 001 second to 255 seconds. All loops programmed as type [0] will have the entry and exit delays as programmed in section [17] or the default times if section [17] is not programmed.

[1] Instant Loop is normally used for door and window contacts and has the standard exit delay but is instant when opened after the exit delay expires. The exit delay will be the default time of 120 seconds or the time as established in programming section [17].

[2] Interior Loop is normally used with interior motion detectors and has the standard exit delay time. The loop also has the standard entry delay time provided that a delay loop has been tripped first. If the premises are entered without coming through a "delay" entrance, and a type [2] loop is tripped, an immediate alarm will be generated.

[3] Interior Home-Away Loop operates the same as the type [2] loop with the following exception. If the system is armed and the delay loop is NOT tripped during the exit delay time, the type [3] loop will be bypassed. Instead of the interior portion of an interior Home-Away loop, a Home-Away loop can have a delay equal to the standard entry and exit delay when section [32], light 3 is ON. This will affect all Home-Away zones when they are not bypassed by [★][1][★][9] arming, or by arming and not leaving the premises. If Home-Away zones are automatically bypassed or [★][9] arming bypassed and the user then enters [★][1], the Home-Aways will then have a delay.

[4] 24 Hour Bell Loop is active at all times and will create an alarm if the panel is armed or disarmed. This loop will always activate the bell/siren output, unless programmed as silent in digit #1 of the zone definition.

[5] 24 Hour Bell/Buzzer operates as the type [4] except the bell/siren output is activated only when the panel is armed and only the keypad buzzer is activated while the panel is disarmed.

[6] 24 Hour Buzzer operates as the type [4] except only the buzzer will be activated in the armed or disarmed mode.

[7] Auxiliary Delay Loop operates the same as the type [0] loop except the entry/exit times can be independently set in section [18]. This loop type is useful when a loop with an entry and/or exit time is required that is different from the standard times as established for type [0] zones in section [17]. If section [32], light 5 is ON it will enable the system to be armed even if the auxiliary delay loop is open ("Ready" light ON). Also, the system can be armed with the auxiliary delay loop closed and then it can be opened before the auxiliary exit delay has expired. In both cases the auxiliary delay loop will not become active until both the auxiliary exit delay has expired and the loop is closed.

[8] Fire Loop Although a common fire signal is reported, any one of the 6 zones may be programmed as a fire loop. A fire loop is a supervised (N.O. alarm initiating contacts), end-of-line resistor circuit designed to accept latching 4-wire smoke detectors. See the Control Panel Wiring Diagram.

On alarm, fire loop shorted, the bell / siren will sound using the Temporal Fire pattern or will pulse to indicate that a fire loop has been activated. Transmission by the digital communicator is delayed 30 seconds. If the alarm is acknowledged before the 30 second delay has expired, pressing [#] will silence the alarm and abort the transmission. If the alarm is NOT acknowledged within the 30 second period, transmission will proceed and cannot be aborted. If the alarm has been silenced and all smoke detectors are not restored to normal, the alarm will re-sound after 90 seconds; 30 seconds after that, the communicator will transmit. If the alarm re-sounds, it may again be silenced by pressing [#] and the communicator transmission will be aborted if the alarm is silenced within the 30 second transmission delay period. Temporal Fire pattern is 0.5 sec ON, 0.5 sec OFF, 0.5 sec ON, 0.5 sec OFF, 0.5 sec ON, 1.5 sec OFF.

To restore smoke detectors to normal, clear all smoke from the detectors and perform a reset by pressing [*][7]. See section [24] for programming the PGM terminal for smoke detector reset. Pressing [*][7] will remove power from the smoke detectors for 5 seconds; if the detectors are clear of smoke, they will return to normal. If the detectors still have smoke in them, the alarm will re-sound and the sequence described above will repeat.

For an open on any loop programmed for fire, the "Trouble" light will come ON and the keypad sounder will beep every 10 seconds. The keypad trouble buzzer will sound and the "Trouble" light will come ON regardless of whether the panel is armed or disarmed. The communicator will transmit the trouble condition if programmed in section [09]. The audible trouble indication may be silenced by pressing [#]. The "Trouble" light will only go OFF when all the fire loop troubles are cleared. To determine the type of trouble, press [*][2].

Section [11], Digit #2 Summary:

- [0] = Standard delay loop
- [1] = Instant loop
- [2] = Interior Loop
- [3] = Interior... home / away loop
- [4] = 24 hour... bell loop
- [5] = 24 hour... bell / buzzer loop
- [6] = 24 hour... buzzer loop
- [7] = Auxiliary delay loop
- [8] = Fire Loop

[12] 1st System Option Code

The 1st System Option Code is set using the zone lights as shown in the table below. Once section [12] is entered, the 6 zone lights will indicate the status of each option. Press a number key corresponding to the zone light number to turn the option ON and OFF. Pressing [0] will turn all the zone lights OFF and the options will be set as shown against "Light Off".

ZONE LIGHT

- [1] ON = Communicator disabled
• OFF = Communicator Enabled
- [2] ON = Transmission per 24 hour period
• OFF = Transmission per armed period
- [3] ON = Alarm display while armed
OFF = No alarm display while armed
- [4] ON = DTMF dialling*
OFF = Pulse dialling
- [5] ON = N.C. loops (except fire loops)
• OFF = End-of-line resistor loops
- [6] ON = Keypad [P]anic audible
OFF = Keypad [P]anic silent

- Factory default settings

* DTMF dialling will default to pulse dialling after 2 unsuccessful DTMF dialling attempts.

[13] 2nd System Option Code

Use the same method of programming as section [12].

ZONE LIGHT

- [1] ON = Call 1st phone number only
OFF = Call 1st phone number with back-up to 2nd phone number
- [2] ON = Master Code not user changeable
• OFF = Master Code user changeable
- [3] ON = Bell squawk enabled*
• OFF = Bell squawk disabled
- [4] ON = PC16OUT module enabled
• OFF = PC16OUT module disabled
- [5] ON = 6th code is "maid's code" (one-time use)
• OFF = 6th code is normal access code
- [6] ON = 1400 Hz handshake for Radionics formats # 3, 4, B and C
• OFF = 2300 Hz handshake for Radionics formats # 3, 4, B and C

- Factory default settings

* With bell squawk enabled, the bell / siren will sound one short burst on arming and two short bursts on disarming.

NOTE: When the panel is set for Auto-Arming, the bell / siren will sound 1 short burst every 10 seconds for one minute before the panel Auto-Arms unless the 'Bell During Auto-Arm' is disabled (section [32], light 2).

[14] 3rd System Option Code

Use the same method of programming as section [12].

ZONE LIGHT

- [1] ON = Access code required for bypass
• OFF = Access code not required for bypass
- [2] ON = Enable [*][4] downloading call feature
• OFF = Disable [*][4] call feature¹
- [3] ON = Periodic downloading²
• OFF = Periodic test transmission
- [4] ON = [*][4] requires a access code
• OFF = [*][4] does not require access code
- [5] ON = [P]anic key has keypad-audible feedback
OFF = [P]anic key without keypad-audible feedback
- [6] ON = Partial closings identified³
• OFF = Partial closings not identified

- Factory default settings

¹ When option [2] is enabled, the user or on-site installer can initiate a call to the downloading computer by pressing [*][4].

² The panel can be enabled to periodically call the downloading computer. The cycle time (in days) for the call is set in section [17]. The automatic call to the downloading computer can be used to update the panel program and / or to upload status information from the panel.

³ If partial closings are enabled as identified, then alarm codes for the bypassed zones will be transmitted.

[15] Communication Variables

Once this section is entered, two 2-digit numbers are expected. Do not press [#] while entering data. The first 2-digit number defines the number of attempts (alarm and restoral pairs) per zone that the communicator will make before it shuts down for that zone (swinger shutdown). The number of attempts is for the period as defined in the 1st System Option Code Section, zone light 2. The number of attempts may be programmed from '00' to '99', where '00' means the communicator will never shut down. The fire zone cannot be shut down - it always transmits.

The second 2-digit number defines the delay before transmission, for zones defined as burglary zones only. 24 hour loops or the fire loop will not be delayed. The time may be programmed from '00' to '99' seconds, where '00' means no delay. **NOTE:** For UL installations, the Maximum Transmissions section cannot be enabled. Also, the Delay Before Transmission must not exceed 15 seconds.

[16] Zone Bypass Mask

Use the same method of programming as used in section [12]. If the zone light is ON, the zone can be bypassed; if OFF, the zone cannot be bypassed using [Q][1]. The fire zone cannot be bypassed.

[17] System Times

There are 6 system times which can be programmed in this section, and each entry requires a 3-digit number. Do not press [#] during data entry.

[1] Entry delay time (001 to 255 seconds) This value determines the standard Entry Delay time. The factory default entry time is 30 seconds. See Section [11] for zone definitions.

[2] Exit delay time (001 to 255 seconds) This value determines the standard Exit Delay time. The factory default exit time is 120 seconds. For zone definitions, see Section [11].

[3] Bell cut-off time (001 to 255 minutes) This value determines the time the bell / siren will sound before automatically turning off. The factory default bell cut-off time is 4 minutes.

[4] AC fail transmission delay (001 to 255 minutes) This value determines the length of time before the communicator will transmit an AC failure report. The factory default time is 30 minutes.

[5] "Slow" zone response time (001 to 255 × 10 ms) This value determines the "slow" zone response time and provides times from 10 ms to 2550 ms. The factory default "slow" zone response time is 500 ms. **NOTE:** The "fast" zone response time is fixed at 10 ms. See Section [11] Zone Definitions.

[6] Test transmission cycle time (001 to 255 days) This value determines the frequency, in days, of the test transmission either via the communicator or by calling the downloading computer. The factory default setting is 30 days. See Section [14] 3rd System Option Code, light 3.

[18] Auxiliary Delay Loop Entry/Exit Times

This section requires two 3-digit entries to establish the Auxiliary Entry and Exit Delay times. Do not press [#] during data entry. The default Entry Delay is 45 seconds and may be changed to any time from 001 seconds to 255 seconds. The default Exit Delay is 120 seconds and may be changed to any time between 001 to 255 seconds.

For auxiliary delay zone times to be effective, the zone must be programmed as a type [7] in the Zone Definition Section [11].

[19] System Clock Times

This section requires two 4-digit entries to set the Automatic Arming Time of Day and the Test Transmission Time of Day. Do not press [#] during data entry. Factory default for both these times is '9999'; that is,

NO automatic arming or test transmission will take place even if those functions are enabled. VALID times must be entered in this section before these features will function.

The system clock is in military time. Two digits from '00' to '23' are entered for the hour of the day and two digits from '00' to '59' are entered for the minute of the hour.

Test transmission or periodic downloading is selected in section [14] 3rd System Option Code, Light 3. The cycle time in days for the test transmission or periodic downloading is set in section [17] System Times. For a test transmission using the communicator, an automatic test code should be entered in section [10]. For periodic downloading or a test transmission using the communicator, a valid transmission time must be entered in section [19].

NOTE: Upon power-up, if either the Auto-Arm or the test transmission time has a valid time entered, then a loss-of-time trouble for the system clock will be initiated. Enter [★][2] to view the trouble. Light 6 will be ON. If neither the Auto-Arm nor Test Transmission have a valid time, then a trouble will not be initiated.

[20] New Installer's Code

[21] New Master Code

[22] 2nd Master Code

Once the section number has been entered ([20], [21] or [22]), enter a new 4-digit code. Only use digits 0 through 9 as code numbers. Do not press [★] or [#]. If an error is made entering the code, complete entry of the 4 digits then enter the section number again to enter the correct code.

[23] Communication Formats

This section sets the type of format which will be sent to each of the two telephone numbers programmed in section [01] and [03]. For each telephone number, enter one digit from the list below. See the HEX data programming section for details on how to enter digits 'A' through 'F'. The selection for each phone number is determined by the type of receiver being called. Enter the format number for the 1st telephone number first. It is necessary to program both telephone format numbers even if the first phone number is the only one being used.

- [0] SILENT KNIGHT / ADEMCO SLOW 10 BPS
(1400 Hz handshake)
3/1, 4/1 and 4/2 non-extended formats
- [1] SESCOA, FRANKLIN, DCI, VERTEX 20 BPS
(2300 Hz handshake)
3/1, 4/1 and 4/2 non-extended formats
- [2] SILENT KNIGHT FAST 20 BPS
(1400 Hz handshake)
3/1, 4/1 and 4/2 non extended formats
- [3] RADIONICS
(2300/1400 Hz handshake*)
3/1, 4/2 non extended formats
- [4] RADIONICS
(2300/1400 Hz handshake)
3/1, 4/2 non-extended with parity format
- [5]- [7] DO NOT USE
- [8] SILENT KNIGHT, ADEMCO SLOW 10 BPS
(1400 Hz handshake)
3/1 extended format
- [9] SESCOA, FRANKLIN, DCI, VERTEX 20 BPS
(2300 Hz handshake)
3/1 extended format
- [A] SILENT KNIGHT FAST 20 BPS
(1400 Hz handshake)
3/1 extended format
- [B] RADIONICS
(2300 / 1400 Hz handshake*)
3/1 extended format

[C] RADIONICS
(2300 / 1400 Hz handshake*)
3/1 extended with parity format

[D] - [F] DO NOT USE

* See section [13] for Radionics handshake option.

Communications Compatibility

All these communication formats are compatible with the Silent Knight model SK9000 and Ademco model 685 receivers. For UL installations, ensure that the control unit is reporting to one of these receivers.

10 BPS and 20 BPS Formats

10 BPS is the standard slow format used on Silent Knight / Ademco receivers. DATA = 1900 Hz; KISSOFF = 1400 Hz; SPEED = 10 baud

20 BPS is the standard fast format used on the DCI / Franklin / SESCOA and Vertex receivers. DATA = 1800 Hz; KISSOFF = 2300 Hz; SPEED = 20 baud

Radionics Format

For conventional Radionics 3/1 format, the communications mode should be set on either Radionics rounds [B] or Radionics parity [C]. The extended version of the Radionics format is normally used. The following guidelines are provided to help in configuring the PC1550 for Radionics format.

1. The customer account code must be only 3 digits with a zero making up the 4th digit (i.e. Enter 1230 to program an account code of 123).
2. The zone alarm reporting codes must all be single digit numerical codes with no extended 2nd round being sent (i.e. Zone 1 = 10, Zone 2 = 20... Zone 6 = 60). The zero in the 2nd digit position tells the PC1550 not to send an extended round.
3. All other non-alarm reporting codes must be set up to send an extended 2nd round. The 1st digit of the reporting code is used to identify the event while the 2nd or extended digit is used to associate the event with a particular item (i.e. A reporting code of E3 means restore zone 3. E = restore, 3 = zone 3).
4. The following is a list of 1st digit identifiers that should be used with the Radionics format.

Restorals "E"	i.e. E3 = restore zone 3
Openings "B"	i.e. B2 = opening by user 2
Closings "C"	i.e. C4 = closing by user 4
Troubles "F"	i.e. F5 = trouble from source 5
Miscellaneous "D"	i.e. D1 = partial closing

[24] Programmable Output Options PGM Terminal

The PGM output can be programmed in this section to operate in response to various panel operations. The output pulse connects the PGM terminal to the negative power rail.

[01] Ground Start Pulse

This option provides a 2-second output pulse before dialling begins to obtain the dial tone on Ground Start telephone equipment.

[02] Utility Output, no Access Code

When activated by entering [★][7], the PGM output will go low for 5 seconds and the keypad buzzer will sound.

[03] Utility Output, any Access Code

The same as [02], except the command is [★][7] [any valid access code].

[04] 5-Second Reset Pulse

When this option is selected, the PGM output is normally low. That is, it is just the reverse of all other options which are normally high and go low when activated. This option is normally used as the negative return for power to 4-wire smoke detectors (positive comes from the AUX + terminal). To activate this output (to reset smoke detectors), enter the [★][7] command. The PGM terminal will go high (open circuit), and thus remove power from the devices connected. The keypad buzzer will sound for the 5-

second period.

[05] Courtesy Pulse

This option provides an output which follows the entry and exit times. It can be used to turn on a courtesy light near the exit door for the duration of the entry / exit times.

[06] Keypad Buzzer Follow Mode

The PGM output will go low as long as the keypad buzzer is ON for "24 Hour Buzzer Zone", "Door Chime", "Entry Delay" and "Auto-Arm Alert".

[07] System Status (Armed / Disarmed)

The PGM output switches to and remains at ground as long as the panel is armed. The output goes high (open) while the panel is disarmed.

[08] Strobe Output (Latched Alarm Output)

The PGM switches to ground on an alarm and remains low until the panel is disarmed. It can be used to indicate that an alarm has occurred before entering the premises.

[09] Failure to Communicate

The PGM output switches to ground if the systems fails to communicate after 8 attempts to each phone number that will be tried according to the communicator call direction options. The output remains low until a successful communication takes place or until trouble #4 is cleared from the keypad. This option can be used to tie two systems together so that if one fails to communicate, the other system will report the failure.

[0A] PGM ON during Entry Delay

The PGM output will be switched on for the duration of the Entry Delay. This option may be used to provide lighting in the entrance area, or to activate a device when the Entry Delay begins.

[0B] PGM ON during Exit Delay

The PGM output will be switched on for the duration of the Exit Delay. This option may be used to provide lighting in the exit area, or to activate a device when the Exit Delay begins.

[0C] LINKS1000 Interface

This option configures the system for use with the LINKS1000 Cellular Alarm Communicator. Refer to the LINKS Installation Manual for further programming instructions.

[25] Communicator Call Directions

This section requires four single digit entries using digits 0 to 3 only. This section defines how the communicator will call the telephone numbers programmed in sections [01] and [03] to report the following events:

- Zone Alarms and Restorals
- Access Codes Openings and Closings
- Priority Alarms and Restorals
- Maintenance Alarms and Restorals

Enter ONE digit from the list below for each of the above categories. Factory default = 1 for all 4 code groups.

- [0] Disables the function (no transmission for the group)
- [1] Call 1st phone number and back-up to the 2nd phone number when section [13] light 1 is set to OFF and the panel has made 8 unsuccessful tries on the 1st phone number.
- [2] Call the 2nd phone number only
- [3] Always call both phone numbers

If [#] is pressed during data entry, you will be returned to the installer's programming mode and data for this section will NOT be saved.

[26] Downloading Telephone Number

This telephone number is used by the panel to call the downloading computer when a request to call is made by entering [★][4] or for an auto-download. See section [14] 3rd System Option Code, lights 2 and 3. See section [01] 1st Phone Number for instructions on programming the downloading telephone number.

[27] Downloading Access Code

This 4-digit code allows the panel to confirm that it is communicating with a valid downloading computer. Enter 4 digits using the numbers 0 through 9 only. The factory default code is [1515].

[28] Panel Identification Code

This 4-digit code allows the downloading computer to confirm the identity of the control panel. Enter 4 digits using the number keys 0 through 9 only. The factory default code is [1501].

[29] Number of Rings Before Answering

Section [29] is used to set the number of rings before the panel will pickup and answer the call. See section [31] for information on using the panel with an answering machine connected to the same phone line.

[30] Reset to Factory Default

Software

Entering [30] will perform a software reset to the factory default values. Once this command is entered, the keypad buzzer will beep several times. The "Trouble" LED will be ON during the reset sequence.

Hardware

If the installer's code is forgotten and a software reset cannot be performed, the panel can be reset to the factory default values with the following method.

1. Remove all power, AC and battery, from the panel.
2. Short the pads on the panel labelled EEPROM RESET.
3. While maintaining the short, power-up the panel and wait for at least 10 seconds before removing the short.
4. Upon removal of the short, the keypad buzzer will beep and the panel will be reset to the factory default values.

[31] 4th System Option Code

Use the same method of programming as section [12].

ZONE LIGHT

- [1] ON = Able to answer call from downloading computer
 - OFF = Cannot answer call from downloading computer
- [2] ON = Enable callback to downloading computer
 - OFF = Disable callback to downloading computer
- [3] ON = Enable answering machine over-ride
 - OFF = Disable answering machine over-ride
- [4] ON = Show bypass status while armed or disarmed
 - OFF = Show bypass status while disarmed only
- [5] ON = Set for AC = 50 Hz
 - OFF = Set for AC = 60 Hz
- [6] ON = Restore on bell time-out (if zone is restored)
 - OFF = Restore as follower (when zone restores)

- Factory default

Downloading and Answering Machines

If zone light [3] is ON and the panel is called for 1 or 2 rings only and then called back within a variable time from 1 to 249 seconds (this time set in section [33]), the panel will then answer the second call on the first ring.

If zone light [3] is OFF, it is assumed that there is no answering machine connected to the telephone line, and the panel will capture the line after the set number of rings.

If zone light [3] is OFF and an answering machine is connected and is set to answer before the panel, the panel will be unable to receive a call from the downloading computer. If the panel is set to answer before the answering machine, the answering machine will be unable to receive incoming calls.

[32] 5th System Option Code

Use the same method of programming as section [12].

ZONE LIGHT

- [1] ON = Loss of AC will not cause an AC trouble
 - OFF = Loss of AC will cause AC trouble
- [2] ON = No bell during Auto-Arm (burst every 10

seconds is silenced)

- OFF = 1 burst of bell / siren every 10 seconds during Auto-Arm pre-alert
- [3] • ON = Home-Away zones will have an entry delay when tripped
 - OFF = Home-Away zones act as interior when tripped
- [4] ON = Quick-Exit is enabled ([★][0] ignores 1 transition of a delay zone)
 - OFF = Quick-Exit is disabled
- [5] ON = Auxiliary delay loops can be force armed
 - OFF = Auxiliary delay loops cannot be force armed
- [6] • ON = Standard Fire – Fire Alarms will pulse bell.
 - OFF = Temporal Fire – Fire Alarms will sound bell using the Temporal Fire Pattern.

Temporal Fire pattern is 0.5 sec ON, 0.5 sec OFF, 0.5 sec ON, 0.5 sec OFF, 0.5 sec ON, 1.5 sec OFF.

- Factory default

[33] Answering Machine Double Call Timer

This location sets the amount of time between calls when using the answering machine over-ride feature. See section [31], light 3.

[34] 6th System Option Code

Use the same programming method as in Section [12].

ZONE LIGHT

- [1] ON = Audible Exit Delay with urgency
 - OFF = Standard Exit Delay
- [2] ON = Bell Squawk during Exit Delay
 - OFF = No Bell Squawk during Exit Delay
- [3] ON = Audible Exit Fault enabled
 - OFF = Audible Exit Fault disabled
- [4] ON = Urgency applied to Entry Delay
 - OFF = Standard Entry Delay
- [5] ON = Bell Squawk during Entry Delay
 - OFF = No Bell Squawk during Entry Delay
- [6] ON = [F] Key disabled
 - OFF = [F] Key enabled

- Factory default

When Light 3 is ON (Audible Exit Fault): When the system is armed and a Standard Delay Zone is left open at the end of the Exit Delay, the bell/siren will sound a steady tone for the duration of the Entry Delay.

Entry and Exit Delay Urgency: When the urgency option is selected for the audible Entry Delay, the keypad will sound a constant tone during the Entry Delay. During the last 10 seconds of the Entry Delay, the keypad will sound a pulsing tone to warn that the delay is about to expire.

When the urgency option is selected for the audible Exit Delay, the keypad will sound a pulsing tone during the Exit Delay. During the last 10 seconds of the Exit Delay, the keypad will sound a faster pulsing tone to warn that the delay is about to expire.

[35] LINKS1000 Test Reporting Code

Cellular communications through the LINKS1000 Cellular Alarm Transmitter will be tested periodically according to the test transmission times programmed in Sections [17] and [19]. The reporting codes programmed in Section [35] will be transmitted during the cellular transmission test.

When the cellular test transmission is completed, the Automatic Test Code programmed in Section [10] will be transmitted over the regular telephone line.

[36] Keypad Lockout Control

Program two 2-digit numbers in this section.

The first entry determines how many invalid codes may be entered before the keypad is locked out and will not accept any further entries. Program a number from 00 to 99; 00 disables the keypad lockout function.

The second entry determines how long, in minutes, the keypad will be locked out once the programmed number of invalid codes are entered. Program a time from 00 to 99 minutes.

[90] Installer's Lockout Enable

This feature is enabled by entering [90] while in the installer's programming mode. A factory default (hardware or software) will not reset the installer's code or the download access code once this feature is enabled. A panel that has this feature enabled will give a distinct audible indication upon power-up. This indication is the phone line relay clicking 10 times. Make sure that your new installer's code has been entered correctly before enabling this feature because there is no way of re-entering the programming mode without the new installer's code. Remember that even a reset to the factory default will not change the installer's code back to the default.

NOTE: Panels returned to DSC with the installer's lockout feature enabled and no other apparent problems will be subject to an additional service charge.

[91] Installer's Lockout Disable

Entering [91] when in the installer's programming mode will disable the installer's lockout feature.

Guidelines for Locating Smoke Detectors

Experience has shown that all hostile fires in residential units generate smoke to a greater or lesser extent. Experiments using typical fires in residential units indicate that detectable quantities of smoke precede detectable levels of heat in most cases. For these reasons, smoke detectors should be installed outside of each sleeping area and on each additional story of the dwelling.

The following information is for general guidance only. The smoke detector manufacturer's literature should be consulted for detailed installation instructions.

On smooth ceilings, detectors may be spaced 9.1m (30 feet) apart as a guide. Other spacing may be required depending on ceiling height, air movement, the presence of joists, uninsulated ceilings, etc. Consult National Fire Alarm Code NFPA 72, CAN/ULS-S553-M86 or other appropriate national standards for installation recommendations.

- Do not locate smoke detectors at the top of peaked or gabled ceilings; the dead air space in these locations may prevent the unit from detecting smoke.
- Avoid areas with turbulent air flow, such as near doors, fans or windows. Rapid air movement around the detector may prevent smoke from entering the unit.
- Do not locate detectors in areas of high humidity.
- Do not locate detectors in areas where the temperature rises above 38°C (100°F) or falls below 5°C (41°F).

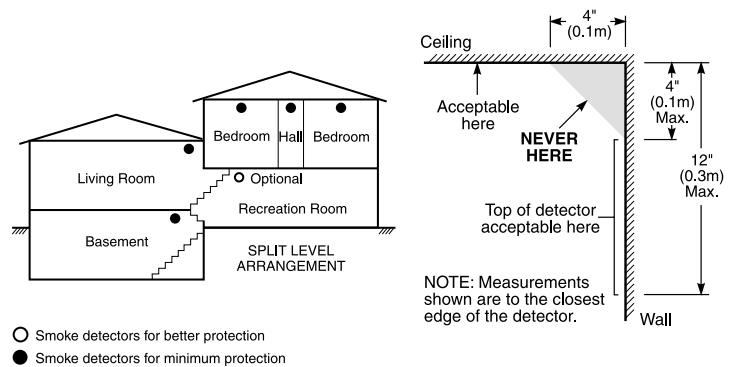
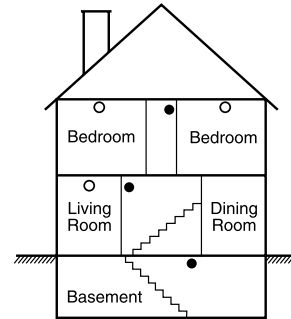
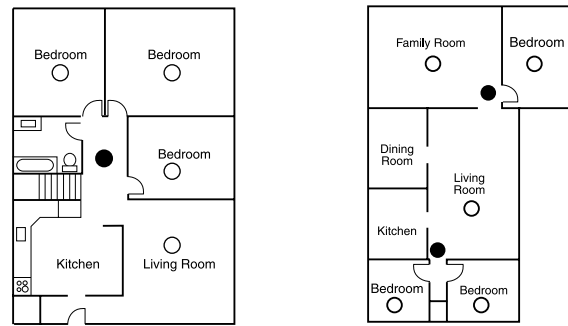

Smoke detectors should always be installed in accordance with NFPA 72, the National Fire Alarm Code. Smoke detectors should always be located in accordance with:

- Paragraph 2-2.1.1.1 of NFPA 72: "Smoke detectors shall be installed outside of each separate sleeping area in the immediate vicinity of the bedrooms and on each additional story of the family living unit, including basements and excluding crawl spaces and unfinished attics. In new construction, a smoke detector also shall be installed in each sleeping room."
- Paragraph 2-2.1.1.2 of NFPA 72: "Split level arrangement. Smoke detectors are required where shown. Smoke detectors are optional where a door is not provided between living room and recreation room."

NOTE: In sections [01] to [10], do not enter data into sections that are not used.

[01] 1st Phone Number *Page 8*

Enter [0] for the digit 0 in the phone number. Enter [★4★] (HEX D) for additional dial tone detection between number digits, as in local PBX systems. Enter [#] to end the phone number entry

[02] 1st Account Code *Page 8*

Enter [★1★] (HEX A) for the digit "0" in the account code. For a 3-digit code, enter [0] for the 4th digit.

[03] 2nd Phone Number *Page 9*

NOTE: For UL installations, the second phone number must not be activated, as the total number of dialing attempts would be greater than 10.

[04] 2nd Account Code *Page 9*

[05] Zone Alarm Reporting Codes *Page 9*

For single digit reporting codes, enter [0] as the second digit. Enter [★1★] (HEX A) to transmit a "zero".

___ Zone 1 Alarm	___ Zone 4 Alarm
___ Zone 2 Alarm	___ Zone 5 Alarm
___ Zone 3 Alarm	___ Zone 6 Alarm

[06] Zone Restoral Reporting Codes *Page 9*

For single digit reporting codes, enter [0] as the second digit. Enter [★1★] (HEX A) to transmit a "zero".

___ Zone 1 Restoral	___ Zone 4 Restoral
___ Zone 2 Restoral	___ Zone 5 Restoral
___ Zone 3 Restoral	___ Zone 6 Restoral

[07] Closing (Arming) Reporting Codes / Partial Closing Reporting Code *Page 9*

___ Access Code 1	___ Access Code 4
___ Access Code 2	___ Access Code 5
___ Access Code 3	___ Access Code 6
	___ Partial Closing Code

[08] Opening (Disarming) Reporting Codes / After Alarm Reporting Code *Page 9*

The "after alarm" code is sent on disarming if an alarm occurred during the previous armed period.

___ Access Code 1	___ Access Code 4
___ Access Code 2	___ Access Code 5
___ Access Code 3	___ Access Code 6
	___ After Alarm Code

[09] Priority Alarms and Restorals *Page 9*

Pressing the [F], [A] or [P] keys will immediately transmit both an alarm and restoral code. There is no delay on the restoral code transmission.

___ Fire Loop Trouble	___ Fire Loop Trouble Restore
___ Keypad [P]anic Alarm	___ Keypad [P]anic Restore
___ Keypad [F]ire Alarm	___ Keypad [F]ire Restore
___ Keypad [A]uxiliary Alarm	___ Keypad [A]uxiliary Restore

[10] Maintenance Alarms and Restorals *Page 10*

For automatic test code reporting, time between reports (in days) must be specified in Section [17], and time of day for the report must be entered in Section [19]. **NOTE:** For UL installations, either AC failure or battery trouble reporting must be enabled.

___ Low Battery Alarm	___ AC Fail Restore
___ AC Fail Alarm	___ PTC Failure Restore
___ PTC Failure Alarm	___ Automatic Test Code
___ Low Battery Restore	

[11] Zone Definitions Page 10

NOTE: When defining zones, assign delay zones first to zones 1,2,3..., then assign the other zone types to the remaining zones in any order desired.

Default	First Digit	Second Digit
<u>0,0</u> <u> </u> Zone 1	0 = Slow, Audible	0 = Standard Delay
<u>0,1</u> <u> </u> Zone 2	1 = Slow, Silent	1 = Instant
<u>0,1</u> <u> </u> Zone 3	2 = Fast, Audible	2 = Interior
<u>0,2</u> <u> </u> Zone 4	3 = Fast, Silent	3 = Interior, Home-Away
<u>0,2</u> <u> </u> Zone 5		4 = 24 Hour Bell
<u>0,8</u> <u> </u> Zone 6		5 = 24 Hour Bell/Buzzer
		6 = 24 Hour Buzzer
		7 = Aux. Delay (Uses Auxiliary Entry/ Exit Times)
		8 = Fire•

- Any **one** zone may be set as a FIRE zone.

[12] 1st System Option Code Page 11

Default	Zone Light ON	Zone Light OFF
<u>OFF</u> <u> </u> Zone Light 1	Communicator disabled	Communicator enabled
<u>OFF</u> <u> </u> Zone Light 2	TX limit to 24 hour period	TX limit to armed period
<u>ON</u> <u> </u> Zone Light 3	Alarm display while armed	No alarm display while armed
<u>ON</u> <u> </u> Zone Light 4	DTMF dialling	Pulse dialling
<u>OFF</u> <u> </u> Zone Light 5	N.C. loops (except fire)	EOL resistor loops
<u>ON</u> <u> </u> Zone Light 6	Keypad [P]anic audible (bell)	Keypad [P]anic silent (bell)

[13] 2nd System Option Code Page 11

Default	Zone Light ON	Zone Light OFF
<u>ON</u> <u> </u> Zone Light 1	Call 1st phone only	Backup to 2nd phone ¹
<u>OFF</u> <u> </u> Zone Light 2	Master Code not changeable	Master Code changeable
<u>OFF</u> <u> </u> Zone Light 3	Bell Squawk enabled ²	Bell Squawk disabled
<u>OFF</u> <u> </u> Zone Light 4	PC16 OUT enabled	PC16 OUT disabled
<u>OFF</u> <u> </u> Zone Light 5	6th code is maid's code	6th code normal
<u>OFF</u> <u> </u> Zone Light 6	1400 Hz Radionics	2300 Hz Radionics

¹ Do not program "OFF" unless 2nd phone number is programmed.

² With Bell Squawk enabled, the bell/siren will sound one short burst on arming and two short bursts on disarming.

[14] 3rd System Option Code Page 11

Default	Zone Light ON	Zone Light OFF
<u>OFF</u> <u> </u> Zone Light 1	User code required for bypass	Code not required
<u>OFF</u> <u> </u> Zone Light 2	[★] [4] Enabled	[★] [4] Disabled
<u>OFF</u> <u> </u> Zone Light 3	Periodic downloading	Periodic test transmit
<u>OFF</u> <u> </u> Zone Light 4	[★] [4] access code required	[★] [4] no code required
<u>ON</u> <u> </u> Zone Light 5	[P]anic audible (buzzer)	[P]anic silent (buzzer)
<u>OFF</u> <u> </u> Zone Light 6	Partial closing identified	Not identified

[15] Communication Variables Page 11

Default NOTE: For UL installations, the Maximum Transmissions section cannot be enabled. Also, the Delay Before Transmission must not exceed 15 seconds.

03 Maximum transmissions per burglary zone

Enter digits from "01" to "99" for number of transmissions per zone during the period as defined in Section [12], 1st System Option Code, Zone Light 2. Note that "00" = unlimited transmissions per burglary zone. **Fire zone always transmits.**

Default

00 Delay before transmission (burglary zones only)

Enter digits from "01" to "99" - delay in seconds; "00" = no delay. **Fire zone and 24 hour zone transmissions cannot be delayed.** Transmission delay as programmed here is for burglary zones only.

[16] Zone Bypass Mask Page 11

If the zone light is ON, the zone can be bypassed using the [★][1] command. If a zone is defined as a fire zone, it cannot be bypassed.

Default

ON Zone Light 1

ON Zone Light 2

ON Zone Light 3

Default

ON Zone Light 4

ON Zone Light 5

ON Zone Light 6

[17] System Times Page 11

Default

030 Entry Delay (seconds)

120 Exit Delay (seconds)

004 Bell Cut-off (minutes)

Default

030 AC fail transmission delay (minutes)

050 Slow loop response time (x 10 ms)

030 Test transmission cycle or auto download cycle time (days)

Valid entries are "001" to "255". **Do not enter "000".**

[18] Auxiliary Delay Loop Entry / Exit Times Page 12

Default

045 Entry Time (seconds)

120 Exit Time (seconds)

Valid entries are "001" to "255".

[19] System Clock Times Page 12

Default

9999 Automatic Arming (time of day)

9999 Test transmission or auto download (time of day)

Enter 4 digits - "00" to "23" hours; "00" to "59" minutes. If a feature is not used, leave at the default setting of "9999".

For Sections [20], [21] and [22]: Enter 4 digits from "0" to "9". Do not enter [★] or [#].

[20] New Installer's Code Page 12

Default

1500

[21] New Master Code Page 12

Default

1234

[22] 2nd Master Code Page 12

Default

AAAA

The 2nd Master Code can be erased by entering [★1111]. AAAA = not programmed

[23] Communication Formats Page 12

It is necessary to program the format for **both** numbers, even if the second telephone number is not used.

Default

1 1st Telephone Number

Default

1 2nd Telephone Number

Enter one HEX digit from [0] to [F] for each phone number from the following list:

- | | | | |
|---------|--------------------------------------|-----------------------------|--|
| [0] | SILENT KNIGHT / ADEMCO SLOW 10 BPS | (1400 Hz handshake) | 3/1, 4/1 and 4/2 non-extended formats |
| [1] | SESCOA, FRANKLIN, DCI, VERTEX 20 BPS | (2300 Hz handshake) | 3/1, 4/1 and 4/2 non-extended formats |
| [2] | SILENT KNIGHT FAST 20 BPS | (1400 Hz handshake) | 3/1, 4/1 and 4/2 non extended formats |
| [3] | RADIONICS | (2300/1400 Hz handshake•) | 3/1, 4/2 non extended formats |
| [4] | RADIONICS | (2300/1400 Hz handshake) | 3/1, 4/2 non-extended with parity format |
| [5]-[7] | DO NOT USE | | |
| [8] | SILENT KNIGHT, ADEMCO SLOW 10 BPS | (1400 Hz handshake) | 3/1 extended format |
| [9] | SESCOA, FRANKLIN, DCI, VERTEX 20 BPS | (2300 Hz handshake) | 3/1 extended format |
| [A] | SILENT KNIGHT FAST 20 BPS | (1400 Hz handshake) | 3/1 extended format |
| [B] | RADIONICS | (2300 / 1400 Hz handshake•) | 3/1 extended format |
| [C] | RADIONICS | (2300 / 1400 Hz handshake•) | 3/1 extended with parity format |

[D]-[F] DO NOT USE

- See Section [13] for Radionics handshake option.

[24] Programmable Output Options (PGM Terminal) Page 13

Default Enter 2 digits from "01" to "0C" only.

0 4

Programmable Output:

- | | | | |
|------|---|------|--|
| [01] | Ground Start Pulse | [07] | System Status (arm/disarm) Output |
| [02] | Utility Output, No Access Code - 5 seconds [★] [7] | [08] | Strobe Output (latched alarm output) |
| [03] | Utility Output, Any Access Code - 5 seconds [★] [7] | [09] | Failure to Communicate Output - follows trouble #4 |
| [04] | 5 Second Reset Pulse [★] [7] | [0A] | PGM ON during Entry Delay |
| [05] | Courtesy Pulse (follows entry/exit times) | [0B] | PGM ON during Exit Delay |
| [06] | Keypad Buzzer Follow Mode• | [0C] | LINKS1000 Interface |

- [06] Buzzer follows the entry delay, door chime, auto-arm alert period and 24 hour buzzer loop.

[25] Communicator Call Directions Page 13

This section must be completely programmed. Do not press [#] to exit until all entries are completed.

Default

- | | | | |
|--------------------|-----------------------------------|-----|--|
| <u>1</u> <u> </u> | Zone Alarms and Restorals | [0] | No transmissions for this group. |
| <u>1</u> <u> </u> | Access Code Openings and Closings | [1] | Call 1st number and backup to 2nd number.• |
| <u>1</u> <u> </u> | Priority Alarms and Restorals | [2] | Call 2nd phone number only. |
| <u>1</u> <u> </u> | Maintenance Alarms and Restorals | [3] | Always call both phone numbers. |

- Section [13] Light 1 "OFF" and 2nd phone number must be programmed.

[26] Downloading Telephone Number Page 13

This telephone number is used by the panel to call the downloading computer either by the periodic download function or through the use of the [★] [4] command. Enter [0] for the digit '0' in the phone number. Enter [★4★] (HEX D) for additional tone detection between number digits, as in local PBX systems. Enter [#] to end the phone number entry.

[27] Downloading Access Code Page 13

Default

1 5 1 5 This code allows the panel to confirm that a valid downloading computer is requesting access.

[28] Panel Identification Code Page 13

Default

1 5 0 1 This code confirms the panel's identity to the downloading computer.

[29] Number of Rings Before Answering *Page 13*

Default

1 2 Enter a number from 01 to 12 to set the number of rings before the panel will answer.

[30] Reset To Factory Default *Page 13*

[31] 4th System Option Code *Page 14*

Default

Zone Light ON

Zone Light OFF

<u>OFF</u> <u> </u> Zone Light 1	Enable download answer	Disable answer
<u>OFF</u> <u> </u> Zone Light 2	Enable download callback	Disable callback
<u>OFF</u> <u> </u> Zone Light 3	Answering machine over-ride	Disable over-ride
<u>OFF</u> <u> </u> Zone Light 4	Show bypass status/armed ¹	Show bypass status/disarmed
<u>OFF</u> <u> </u> Zone Light 5	AC = 50 Hz	AC = 60 Hz
<u>OFF</u> <u> </u> Zone Light 6	Restore on bell time out	Restore as follower

•If zone light 4 is ON, bypass status will always be shown. If zone light 4 is OFF, bypass status is shown only when the panel is disarmed.

[32] 5th System Option Code *Page 14*

Default

Zone Light ON

Zone Light OFF

<u>OFF</u> <u> </u> Zone Light 1	AC excluded from trouble	AC included
<u>OFF</u> <u> </u> Zone Light 2	No bell during auto-arm	Bell during auto-arm
<u>ON</u> <u> </u> Zone Light 3	Home/away with delay	Home/away as interior
<u>OFF</u> <u> </u> Zone Light 4	Quick exit enabled	Quick exit disabled
<u>OFF</u> <u> </u> Zone Light 5	Force arm on auxiliary delay	Auxiliary delay normal
<u>ON</u> <u> </u> Zone Light 6	Standard Fire	Temporal Fire

[33] Answering Machine Double Call Timer *Page 14*

Default

0 6 0 Valid entries are "001" to "249"

[34] 6th System Option Code *Page 14*

Default

Zone Light ON

Zone Light OFF

<u>OFF</u> <u> </u> Zone Light 1	Audible Exit Delay with Urgency	Standard Exit Delay
<u>OFF</u> <u> </u> Zone Light 2	Bell Squawk during Exit Delay	No Bell Squawk during Exit Delay
<u>OFF</u> <u> </u> Zone Light 3	Audible Exit Fault enabled	Audible Exit Fault disabled
<u>OFF</u> <u> </u> Zone Light 4	Urgency applied to Entry Delay	Standard Entry Delay
<u>OFF</u> <u> </u> Zone Light 5	Bell Squawk during Entry Delay	No Bell Squawk during Entry Delay
<u>OFF</u> <u> </u> Zone Light 6	[F] Key disabled	[F] Key enabled

[35] LINKS1000 Test Reporting Code *Page 14*

Default

NOTE: The LINKS1000 is not UL listed.

F F **Program this section only if the LINKS1000 Cellular Alarm Transmitter is being used with the PC1550.**

[36] Keypad Lockout Control *Page 14*

Default

Enter 2 2-digit numbers in the range of 00 to 99. Program the Number of Invalid Codes as "00" to disable the lockout feature.

0 0 Number of Invalid Codes before lockout

0 0 Lockout Duration (minutes)

[90] Installer's Lockout Enable *Page 14*

[91] Installer's Lockout Disable *Page 14*

WARNING! Panels returned to DSC with the Installer's Lockout enabled and no other apparent problems will be subject to an additional service charge!



PC1550 Control Panel Wiring Diagram

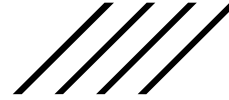

Incorrect connections may result in PTC failure or improper operation. Inspect wiring and ensure connections are correct before applying power. Do not route any wiring over circuit boards. Maintain at least 1" (25.4mm) distance.

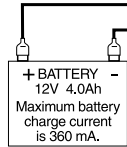
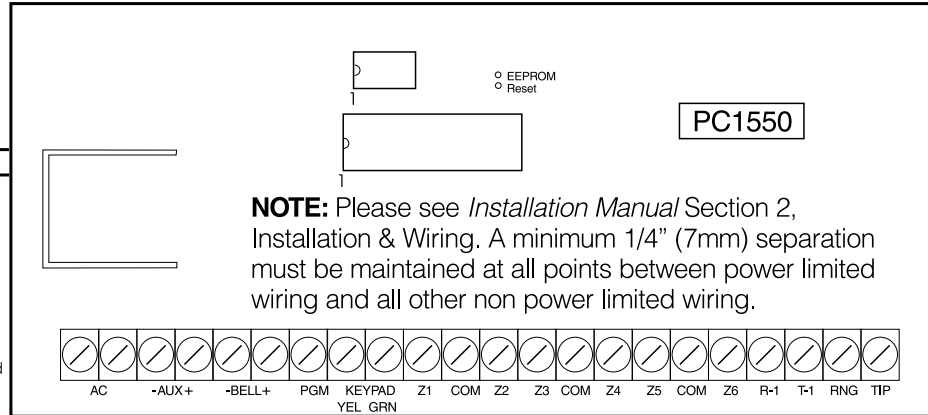

Battery capacity for emergency standby is at least 4 hours if the total load (BELL + AUX O/P) is 800mA or less. Recommended Battery: DSC model BD4-12.

All terminals Class 2 power limited, except the battery leads.

Do not connect transformer to a receptacle controlled by a switch. The transformer must be UL-Listed and have a restraining means.

For fire alarm applications, it is mandatory to use one UL-Listed indoor signalling appliance with a minimum 85dB rating and current rating of 1 Amp or less, and be rated 85dB(A) minimum for indoor residential applications. (WHEELLOCK model MT-12/24-R or equivalent).

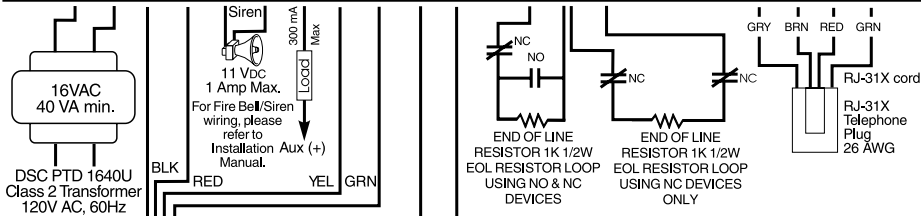

The Auxiliary Output will supply a maximum of 475 mA to power external devices, including keypads.

Temperature Range : 0°C-47°C (32°F-120°F)
Maximum Humidity : 85% R.H.

Refer to Instruction Manual #29000078 R6 for complete operating instructions.

This equipment is UL-Listed for limited energy installations per NEC article 760. Recognized limited energy cable should be used. Observe NEC wiring requirements and local codes as defined by the authority having jurisdiction.

Security detection devices that require power from control panel must be UL-Listed for the intended application and operate over the voltage range of 10.0 to 14.0 Vdc.

The DSC Bravo Series are recommended UL-Listed motion detectors.

This device complies with Parts 15 and 68 of the FCC rules. Operation is subject to the following two conditions: (1) this device may not cause harmful interference, and (2) this device must accept any interference received, including interference that may cause undesired operation.

FCC Reg. No.: F53CAN-73151-AL-E REN = 0.1B

Plug Type: RJ-31X

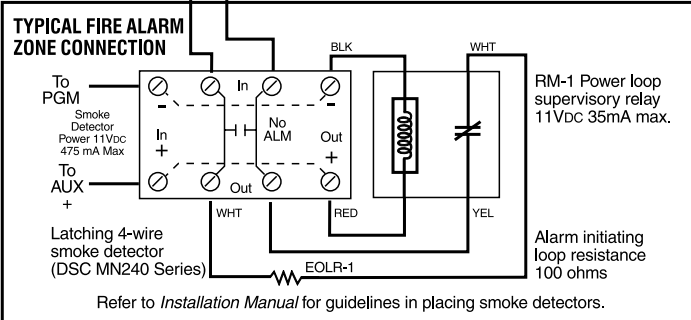

Applicable UL Standards UL File No. S4019
UL985 Household fire Warning System Units
UL1023 Household Burglar-Alarm System Units
UL1635 Digital Alarm Communicator System Units

Control Panel is suitable for the following UL Installations:

- Household Fire
- Household Burglary
- Refer to installation manual

WARNING: Not to be removed by anyone except occupant. This equipment should be installed in accordance with the National Fire Code ANSI/NFPA 72 (National Fire Protection Association, Batterymarch Park, Quincy MA, 02269). Printed information describing proper installation, operation, testing, maintenance, evacuation planning, and repair service is to be provided with this equipment.

UL Listed Residential Installations

Residential Installations

- The entry delay must not exceed 45 seconds
- The exit delay must not exceed 60 seconds.
- The minimum bell cutoff time is 4 minutes.

Programming

The notes in the programming sections describing the system configurations for UL Listed installations must be implemented.

Control of the Protected Premises

In order to have a UL Certificated system the protected area is to be under the responsibility of one ownership and management (i.e. one business under one name). This may be a group of buildings attached or unattached with different addresses but under the responsibility of someone having mutual interest. The person of mutual interest is not the alarm installing company.

Bell Location

The alarm sounding device (bell) must be located where it can be heard by the person or persons responsible for maintaining the security system during the daily arming cycle.

Protection of the Control Unit

The local control and the local power supply must be protected by one of the following ways:

- The control unit and audible alarm device must be in a protected area which is armed 24 hours a day.
- Each partition shall arm the area protecting the control unit and the audible alarm device power supply. This may require duplicate protection armed by each partition. Access to this protected area, without causing an alarm, will require that all partitions be disarmed.

In all cases described above, the protected area for the control unit must be programmed as not bypassable.

Casual Users

The installer should caution the user(s) to not give system information to casual users (e.g. codes, bypass methods, etc. to baby-sitters or service people). Only the One-Time Use codes should be given to casual users.

User Information

The installer should advise the users and note in the user instruction manual:

- Service organization name and telephone number
- The programmed exit time
- The programmed entry time

FCC Compliance Statement

CAUTION: Changes or modifications not expressly approved by Digital Security Controls Ltd. could void your authority to use this equipment.

This equipment has been tested and found to comply with the limits for a Class B digital device, pursuant to Part 15 of the FCC Rules. These limits are designed to provide reasonable protection against harmful interference in a residential installation. This equipment generates, uses and can radiate radio frequency energy and, if not installed and used in accordance with the instructions, may cause harmful interference to radio communications. However, there is no guarantee that interference will not occur in a particular installation. If this equipment does cause harmful interference to radio or television reception, which can be determined by turning the equipment off and on, the user is encouraged to try to correct the interference by one or more of the following measures:

- Re-orient the receiving antenna.
- Increase the separation between the equipment and receiver.
- Connect the equipment into an outlet on a circuit different from that to which the receiver is connected.
- Consult the dealer or an experienced radio/television technician for help.

The user may find the following booklet prepared by the FCC useful: "How to Identify and Resolve Radio/Television Interference Problems". This booklet is available from the U.S. Government Printing Office, Washington D.C. 20402, Stock # 004-000-00345-4

Important Information

This equipment complies with Part 68 of the FCC Rules. On the side of this equipment is a label that contains, among other information, the FCC registration number of this equipment.

Notification to Telephone Company

Upon request, the customer shall notify the telephone company of the particular line to which the connection will be made, and provide the FCC registration number and the ringer equivalence of the protective circuit.

FCC Registration Number: F53CAN-73151-AL-E

Ringer Equivalence Number: 0.1B **USOC Jack:** RJ-31X

Telephone Connection Requirements

Except for the telephone company provided ringers, all connections to the telephone network shall be made through standard plugs and telephone company provided jacks, or equivalent, in such a manner as to allow for easy, immediate disconnection of the terminal equipment. Standard jacks shall be so arranged that, if the plug connected thereto is withdrawn, no

interference to the operation of the equipment at the customer's premises which remains connected to the telephone network shall occur by reason of such withdrawal.

Incidence of Harm

Should terminal equipment or protective circuitry cause harm to the telephone network, the telephone company shall, where practicable, notify the customer that temporary disconnection of service may be required; however, where prior notice is not practicable, the telephone company may temporarily discontinue service if such action is deemed reasonable in the circumstances. In the case of such temporary discontinuance, the telephone company shall promptly notify the customer and will be given the opportunity to correct the situation.

Additional Telephone Company Information

The security control panel must be properly connected to the telephone line with a USOC RJ-31X telephone jack.

The FCC prohibits customer-provided terminal equipment be connected to party lines or to be used in conjunction with coin telephone service. Inter-connect rules may vary from state to state.

Changes in Telephone Company Equipment of Facilities

The telephone company may make changes in its communications facilities, equipment, operations or procedures, where such actions are reasonably required and proper in its business. Should any such changes render the customer's terminal equipment incompatible with the telephone company facilities the customer shall be given adequate notice to the effect modifications to maintain uninterrupted service.

Ringer Equivalence Number (REN)

The REN is useful to determine the quantity of devices that you may connect to your telephone line and still have all of those devices ring when your telephone number is called. In most, but not all areas, the sum of the RENs of all devices connected to one line should not exceed five (5.0). To be certain of the number of devices that you may connect to your line, you may want to contact your local telephone company.

Equipment Maintenance Facility

If you experience trouble with this telephone equipment, please contact the facility indicated below for information on obtaining service or repairs. The telephone company may ask that you disconnect this equipment from the network until the problem has been corrected or until you are sure that the equipment is not malfunctioning.

Digital Security Controls Ltd., 160 Washburn Street, Lockport, NY 14094

LIMITED WARRANTY

Digital Security Controls Ltd. warrants the original purchaser that for a period of twelve months from the date of purchase, the product shall be free of defects in materials and workmanship under normal use. During the warranty period, Digital Security Controls Ltd. shall, at its option, repair or replace any defective product upon return of the product to its factory, at no charge for labour and materials. Any replacement and/or repaired parts are warranted for the remainder of the original warranty or ninety (90) days, whichever is longer. The original owner must promptly notify Digital Security Controls Ltd. in writing that there is defect in material or workmanship, such written notice to be received in all events prior to expiration of the warranty period.

International Warranty

The warranty for international customers is the same as for any customer within Canada and the United States, with the exception that Digital Security Controls Ltd. shall not be responsible for any customs fees, taxes, or VAT that may be due.

Warranty Procedure

To obtain service under this warranty, please return the item(s) in question to the point of purchase. All authorized distributors and dealers have a warranty program. Anyone returning goods to Digital Security Controls Ltd. must first obtain an authorization number. Digital Security Controls Ltd. will not accept any shipment whatsoever for which prior authorization has not been obtained.

Conditions to Void Warranty

This warranty applies only to defects in parts and workmanship relating to normal use. It does not cover:

- damage incurred in shipping or handling;
- damage caused by disaster such as fire, flood, wind, earthquake or lightning;
- damage due to causes beyond the control of Digital Security Controls Ltd. such as excessive voltage, mechanical shock or water damage;
- damage caused by unauthorized attachment, alterations, modifications or foreign objects;
- damage caused by peripherals (unless such peripherals were supplied by Digital Security Controls Ltd.);
- defects caused by failure to provide a suitable installation environment for the products;
- damage caused by use of the products for purposes other than those for which it was designed;
- damage from improper maintenance;
- damage arising out of any other abuse, mishandling or improper application of the products.

Digital Security Controls Ltd.'s liability for failure to repair the product under this warranty after a reasonable number of attempts will be limited to a replacement of the product, as the exclusive remedy for breach of warranty. Under no circumstances shall Digital Security Controls Ltd. be liable for any special, incidental, or consequential damages based upon breach of warranty, breach of contract, negligence, strict liability, or any other legal theory. Such damages include, but are not limited to, loss of profits, loss of the product or any associated equipment, cost of capital, cost of substitute or replacement equipment, facilities or services, down time, purchaser's time, the claims of third parties, including customers, and injury to property.

Disclaimer of Warranties

This warranty contains the entire warranty and shall be in lieu of any and all other warranties, whether expressed or implied (including all implied warranties of merchantability or fitness for a particular purpose) And of all other obligations or liabilities on the part of Digital Security Controls Ltd. Digital Security Controls Ltd. neither assumes responsibility for nor authorizes any other person purporting to act on its behalf to modify or to change this warranty, nor to assume for it any other warranty or liability concerning this product.

This disclaimer of warranties and limited warranty are governed by the laws of the province of Ontario, Canada.

WARNING: Digital Security Controls Ltd. recommends that the entire system be completely tested on a regular basis. However, despite frequent testing, and due to, but not limited to, criminal tampering or electrical disruption, it is possible for this product to fail to perform as expected.

Installer's Lockout

Any products returned to DSC which have the Installer's Lockout option enabled and exhibit no other problems will be subject to a service charge.

Out of Warranty Repairs

Digital Security Controls Ltd. will at its option repair or replace out-of-warranty products which are returned to its factory according to the following conditions. Anyone returning goods to Digital Security Controls Ltd. must first obtain an authorization number. Digital Security Controls Ltd. will not accept any shipment whatsoever for which prior authorization has not been obtained.

Products which Digital Security Controls Ltd. determines to be repairable will be repaired and returned. A set fee which Digital Security Controls Ltd. has predetermined and which may be revised from time to time, will be charged for each unit repaired.

Products which Digital Security Controls Ltd. determines not to be repairable will be replaced by the nearest equivalent product available at that time. The current market price of the replacement product will be charged for each replacement unit.

WARNING Please Read Carefully

Note to Installers

This warning contains vital information. As the only individual in contact with system users, it is your responsibility to bring each item in this warning to the attention of the users of this system.

System Failures

This system has been carefully designed to be as effective as possible. There are circumstances, however, involving fire, burglary, or other types of emergencies where it may not provide protection. Any alarm system of any type may be compromised deliberately or may fail to operate as expected for a variety of reasons. Some but not all of these reasons may be:

■ Inadequate Installation

A security system must be installed properly in order to provide adequate protection. Every installation should be evaluated by a security professional to ensure that all access points and areas are covered. Locks and latches on windows and doors must be secure and operate as intended. Windows, doors, walls, ceilings and other building materials must be of sufficient strength and construction to provide the level of protection expected. A reevaluation must be done during and after any construction activity. An evaluation by the fire and/or police department is highly recommended if this service is available.

■ Criminal Knowledge

This system contains security features which were known to be effective at the time of manufacture. It is possible for persons with criminal intent to develop techniques which reduce the effectiveness of these features. It is important that a security system be reviewed periodically to ensure that its features remain effective and that it be updated or replaced if it is found that it does not provide the protection expected.

■ Access by Intruders

Intruders may enter through an unprotected access point, circumvent a sensing device, evade detection by moving through an area of insufficient coverage, disconnect a warning device, or interfere with or prevent the proper operation of the system.

■ Power Failure

Control units, intrusion detectors, smoke detectors and many other security devices require an adequate power supply for proper operation. If a device operates from batteries, it is possible for the batteries to fail. Even if the batteries have not failed, they must be charged, in good condition and installed correctly. If a device operates only by AC power, any interruption, however brief, will render that device inoperative while it does not have power. Power interruptions of any length are often accompanied by voltage fluctuations which may damage electronic equipment such as a security system. After a power interruption has occurred, immediately conduct a complete system test to ensure that the system operates as intended.

■ Failure of Replaceable Batteries

This system's wireless transmitters have been designed to provide several years of battery life under normal conditions. The expected battery life is a function of the device environment, usage and type. Ambient conditions such as high humidity, high or low temperatures, or large temperature fluctuations may reduce the expected battery life. While each transmitting device has a low battery monitor which identifies when the batteries need to be replaced, this monitor may fail to operate as expected. Regular testing and maintenance will keep the system in good operating condition.

■ Compromise of Radio Frequency (Wireless) Devices

Signals may not reach the receiver under all circumstances which could include metal objects placed on or near the radio path or deliberate jamming or other inadvertent radio signal interference.

■ System Users

A user may not be able to operate a panic or emergency switch possibly due to permanent or temporary physical disability, inability to reach the device in time, or unfamiliarity with the correct operation. It is important that all system users be trained in the correct operation of the alarm system and that they know how to respond when the system indicates an alarm.

■ Smoke Detectors

Smoke detectors that are a part of this system may not properly alert occupants of a fire for a number of reasons, some of which follow. The smoke detectors may have been improperly installed or positioned. Smoke may not be able to reach the smoke detectors, such as when the fire is in a chimney, walls or roofs, or on the other side of closed doors. Smoke detectors may not detect smoke from fires on another level of the residence or building.

Every fire is different in the amount of smoke produced and the rate of burning. Smoke detectors cannot sense all types of fires equally well. Smoke detectors may not provide timely warning of fires caused by carelessness or safety hazards such as smoking in bed, violent explosions, escaping gas, improper storage of flammable materials, overloaded electrical circuits, children playing with matches or arson.

Even if the smoke detector operates as intended, there may be circumstances when there is insufficient warning to allow all occupants to escape in time to avoid injury or death.

■ Motion Detectors

Motion detectors can only detect motion within the designated areas as shown in their respective installation instructions. They cannot discriminate between intruders and intended occupants. Motion detectors do not provide volumetric area protection. They have multiple beams of detection and motion can only be detected in unobstructed areas covered by these beams. They cannot detect motion which occurs behind walls, ceilings, floor, closed doors, glass partitions, glass doors or windows. Any type of tampering whether intentional or unintentional such as masking, painting, or spraying of any material on the lenses, mirrors, windows or any other part of the detection system will impair its proper operation.

Passive infrared motion detectors operate by sensing changes in temperature. However their effectiveness can be reduced when the ambient temperature rises near or above body temperature or if there are intentional or unintentional sources of heat in or near the detection area. Some of these heat sources could be heaters, radiators, stoves, barbecues, fireplaces, sunlight, steam vents, lighting and so on.

■ Warning Devices

Warning devices such as sirens, bells, horns, or strobes may not warn people or waken someone sleeping if there is an intervening wall or door. If warning devices are located on a different level of the residence or premise, then it is less likely that the occupants will be alerted or awakened. Audible warning devices may be interfered with by other noise sources such as stereos, radios, televisions, air conditioners or other appliances, or passing traffic. Audible warning devices, however loud, may not be heard by a hearing-impaired person.

■ Telephone Lines

If telephone lines are used to transmit alarms, they may be out of service or busy for certain periods of time. Also an intruder may cut the telephone line or defeat its operation by more sophisticated means which may be difficult to detect.

■ Insufficient Time

There may be circumstances when the system will operate as intended, yet the occupants will not be protected from the emergency due to their inability to respond to the warnings in a timely manner. If the system is monitored, the response may not occur in time to protect the occupants or their belongings.

■ Component Failure

Although every effort has been made to make this system as reliable as possible, the system may fail to function as intended due to the failure of a component.

■ Inadequate Testing

Most problems that would prevent an alarm system from operating as intended can be found by regular testing and maintenance. The complete system should be tested weekly and immediately after a break-in, an attempted break-in, a fire, a storm, an earthquake, an accident, or any kind of construction activity inside or outside the premises. The testing should include all sensing devices, keypads, consoles, alarm indicating devices and any other operational devices that are part of the system.

■ Security and Insurance

Regardless of its capabilities, an alarm system is not a substitute for property or life insurance. An alarm system also is not a substitute for property owners, renters, or other occupants to act prudently to prevent or minimize the harmful effects of an emergency situation.

1-800-387-3630

© 2001 Digital Security Controls Ltd.
Toronto, Canada • www.dsc.com
Printed in Canada 29003080 R003