

GS3060

GSM-GPRS INTERFACE

INSTALLATION MANUAL



WARNING: This manual contains information on limitations regarding product use and function and information on the limitations as to liability of the manufacturer.

Table of Contents

INTRODUCTION	1
Features	1
Technical Specifications	1
Ratings	1
Description	2
IDENTIFICATION OF PARTS	3
INSTALLING THE GS3060	4
CONNECTING THE GS3060	4
STATUS LEDS	5
OPERATING PRINCIPLES	6
Simulated Land Line Mode	6
Panel Transmission Monitoring (PTM)	6
GPRS Sequence	6
Inputs	6
Outputs	7
Activating the Outputs	7
Contact ID	7
Events Description	7
Event Codes	7
C-24 REMOTE PROGRAMMING	7
GS3060 WIRING DIAGRAMS	8

IMPORTANT

The equipment is fixed, wall-mounted and shall be installed in the position specified in these instructions. The equipment enclosure must be fully assembled and closed, with all the necessary screws/tabs and secured to a wall before operation. Internal wiring must be routed in a manner that prevents:

- Excessive strain on wire and on terminal connections;
- Loosening of terminal; connections;
- Damage of conductor insulation

WARNING: Never install this equipment during a lightning storm!

Instruct the end-user to:

- Not attempt to service this product. Opening or removing covers may expose the user to dangerous voltages or other risks. Any servicing shall be referred to trained service personnel only.
- Use authorized accessories only with this equipment.

Do not dispose of the battery in fire or water. Disposing of the battery in a fire will cause rupture and explosion;

Do not dispose of the waste battery as unsorted municipal waste. Consult your local regulations and /or laws regarding recycling with regard to this lithium battery pack; Doing so will help protect the environment. Some of the materials that are found within the battery could become toxic if not disposed of properly and may affect the environment.

IMPORTANT READ CAREFULLY: DSC Software purchased with or without Products and Components is copyrighted and is purchased under the following license terms:

- This End User License Agreement ("EULA") is a legal agreement between You (the company, individual or entity who acquired the Software and any related Hardware) and Digital Security Controls, a division of Tyco Safety Products Canada Ltd. ("DSC"), the manufacturer of the integrated security systems and the developer of the software and any related products or components ("HARDWARE") which You acquired.
- If the DSC software product ("SOFTWARE PRODUCT" or "SOFTWARE") is intended to be accompanied by HARDWARE, and is NOT accompanied by new HARDWARE, You may not use, copy or install the SOFTWARE PRODUCT. The SOFTWARE PRODUCT includes computer software, and may include associated media, printed materials, and "online" or electronic documentation.
- Any software provided along with the SOFTWARE PRODUCT that is associated with a separate end user license agreement is licensed to You under the terms of that license agreement.
- By installing, copying, downloading, storing, accessing or otherwise using the SOFTWARE PRODUCT, You agree unconditionally to be bound by the terms of this EULA, even if this EULA is deemed to be a modification of any previous arrangement or contract. If You do not agree to the terms of this EULA, DSC is unwilling to license the SOFTWARE PRODUCT to You, and You have no right to use it.

SOFTWARE PRODUCT LICENSE

The SOFTWARE PRODUCT is protected by copyright laws and international copyright treaties, as well as other intellectual property laws and treaties. The SOFTWARE PRODUCT is licensed, not sold.

1. GRANT OF LICENSE. This EULA grants You the following rights:

- (a) Software Installation and Use** - For each license You acquire, You may have only one copy of the SOFTWARE PRODUCT installed.
- (b) Storage/Network Use** - The SOFTWARE PRODUCT may not be installed, accessed, displayed, run, shared or used concurrently on or from different computers, including a workstation, terminal or other digital electronic device ("Device"). In other words, if You have several workstations, You will have to acquire a license for each workstation where the SOFTWARE will be used.
- (c) Backup Copy** - You may make back up copies of the SOFTWARE PRODUCT, but You may only have one copy per license installed at any given time. You may use the back up copy solely for archival purposes. Except as expressly provided in this EULA, You may not otherwise make copies of the SOFTWARE PRODUCT, including the printed materials accompanying the SOFTWARE.

2. DESCRIPTION OF OTHER RIGHTS AND LIMITATIONS

- (a) Limitations on Reverse Engineering, Decompilation and Disassembly** - You may not reverse engineer, decompile, or disassemble the SOFTWARE PRODUCT, except and only to the extent that such activity is expressly permitted by applicable law notwithstanding this limitation. You may not make any changes or modifications to the Software, without the written permission of an officer of DSC. You may not remove any proprietary notices, marks or labels from the Software Product. You shall institute reasonable measures to ensure compliance with the terms and conditions of this EULA.
- (b) Separation of Components** - The SOFTWARE PRODUCT is licensed as a single product. Its component parts may not be separated for use on more than one HARDWARE unit.
- (c) Single INTEGRATED PRODUCT** - If You acquired this SOFTWARE with HARDWARE, then the SOFTWARE PRODUCT is licensed with the HARDWARE as a single integrated product. In this case, the SOFTWARE PRODUCT may only be used with the HARDWARE as set forth in this EULA.
- (d) Rental** - You may not rent, lease or lend the SOFTWARE PRODUCT. You may not make it available to others or post it on a server or web site.
- (e) Software Product Transfer** - You may transfer all of Your rights under this EULA only as part of a permanent sale or transfer of the HARDWARE, provided You retain no copies, You transfer all of the SOFTWARE PRODUCT (including all component parts, the media and printed materials, any upgrades and this EULA), and provided the recipient agrees to the terms of this EULA. If the SOFTWARE PRODUCT is an upgrade, any transfer must also include all prior versions of the SOFTWARE PRODUCT.
- (f) Termination** - Without prejudice to any other rights, DSC may terminate this EULA if You fail to comply with the terms and conditions of this EULA. In such event, You must destroy all copies of the SOFTWARE PRODUCT and all of its component parts.
- (g) Trademarks** - This EULA does not grant You any rights in connection with any trademarks or service marks of DSC or its suppliers.

3. COPYRIGHT

All title and intellectual property rights in and to the SOFTWARE PRODUCT (including but not limited to any images, photographs, and text incorporated into the SOFTWARE PRODUCT), the accompanying printed materials, and any copies of the SOFTWARE PRODUCT, are owned by DSC or its suppliers. You may not copy the printed materials accompanying the SOFTWARE PRODUCT. All title and intellectual property rights in and to the content which may be accessed through use of the SOFTWARE PRODUCT are the property of the respective content owner and may be protected by applicable copyright or other intellectual property laws and treaties. This EULA grants You no rights to use such content. All rights not expressly granted under this EULA are reserved by DSC and its suppliers.

4. EXPORT RESTRICTIONS

You agree that You will not export or re export the SOFTWARE PRODUCT to any country, person, or entity subject to Canadian export restrictions.

5. CHOICE OF LAW: This Software License Agreement is governed by the laws of the Province of Ontario, Canada.

6. ARBITRATION

All disputes arising in connection with this Agreement shall be determined by final and binding arbitration in accordance with the Arbitration Act, and the parties agree to be bound by the arbitrator's decision. The place of arbitration shall be Toronto, Canada, and the language of the arbitration shall be English.

7. LIMITED WARRANTY

(a) NO WARRANTY

DSC PROVIDES THE SOFTWARE "AS IS" WITHOUT WARRANTY. DSC DOES NOT WARRANT THAT THE SOFTWARE WILL MEET YOUR REQUIREMENTS OR THAT OPERATION OF THE SOFTWARE WILL BE UNINTERRUPTED OR ERROR-FREE.

(b) CHANGES IN OPERATING ENVIRONMENT

DSC shall not be responsible for problems caused by changes in the operating characteristics of the HARDWARE, or for problems in the interaction of the SOFTWARE PRODUCT with non-DSC-SOFTWARE or HARDWARE PRODUCTS.

(c) LIMITATION OF LIABILITY; WARRANTY REFLECTS ALLOCATION OF RISK

IN ANY EVENT, IF ANY STATUTE IMPLIES WARRANTIES OR CONDITIONS NOT STATED IN THIS LICENSE AGREEMENT, DSC'S ENTIRE LIABILITY UNDER ANY PROVISION OF THIS LICENSE AGREEMENT SHALL BE LIMITED TO THE GREATER OF THE AMOUNT ACTUALLY PAID BY YOU TO LICENSE THE SOFTWARE PRODUCT AND FIVE CANADIAN DOLLARS (CAD\$5.00). BECAUSE SOME JURISDICTIONS DO NOT ALLOW THE EXCLUSION OR LIMITATION OF LIABILITY FOR CONSEQUENTIAL OR INCIDENTAL DAMAGES, THE ABOVE LIMITATION MAY NOT APPLY TO YOU.

(d) DISCLAIMER OF WARRANTIES

THIS WARRANTY CONTAINS THE ENTIRE WARRANTY AND SHALL BE IN LIEU OF ANY AND ALL OTHER WARRANTIES, WHETHER EXPRESSED OR IMPLIED (INCLUDING ALL IMPLIED WARRANTIES OF MERCHANTABILITY OR FITNESS FOR A PARTICULAR PURPOSE) AND OF ALL OTHER OBLIGATIONS OR LIABILITIES ON THE PART OF DSC. DSC MAKES NO OTHER WARRANTIES. DSC NEITHER ASSUMES NOR AUTHORIZES ANY OTHER PERSON PURPORTING TO ACT ON ITS BEHALF TO MODIFY OR TO CHANGE THIS WARRANTY, NOR TO ASSUME FOR IT ANY OTHER WARRANTY OR LIABILITY CONCERNING THIS SOFTWARE PRODUCT.

(e) EXCLUSIVE REMEDY AND LIMITATION OF WARRANTY

UNDER NO CIRCUMSTANCES SHALL DSC BE LIABLE FOR ANY SPECIAL, INCIDENTAL, CONSEQUENTIAL OR INDIRECT DAMAGES BASED UPON BREACH OF WARRANTY, BREACH OF CONTRACT, NEGLIGENCE, STRICT LIABILITY, OR ANY OTHER LEGAL THEORY. SUCH DAMAGES INCLUDE, BUT ARE NOT LIMITED TO, LOSS OF PROFITS, LOSS OF THE SOFTWARE PRODUCT OR ANY ASSOCIATED EQUIPMENT, COST OF CAPITAL, COST OF SUBSTITUTE OR REPLACEMENT EQUIPMENT, FACILITIES OR SERVICES, DOWNTIME, PURCHASERS TIME, THE CLAIMS OF THIRD PARTIES, INCLUDING CUSTOMERS, AND INJURY TO PROPERTY.

WARNING: DSC recommends that the entire system be completely tested on a regular basis. However, despite frequent testing, and due to, but not limited to, criminal tampering or electrical disruption, it is possible for this SOFTWARE PRODUCT to fail to perform as expected.

INTRODUCTION

The GS3060 is a wireless backup communicator that sends alarm system information to a System III or System II receiver through a GSM/GPRS wireless network. You can use this wireless communicator with UL/ULC Listed compatible control units, as indicated in the manufacturer's installation instructions.

Features

- Compatible with any UL/ULC listed panel that supports 4- or 10-digit Contact ID
- Simulates land line
- Switches automatically to GSM network in the event of land line trouble (e.g. line down)
- GSM Signal Indicator
- Four programmable outputs
- Contains one 12V - 1.2 Ah battery
- Case Tamper Output
- Land line overvoltage protection
- Dual-band GSM radio
- Four programmable inputs
- GPRS/Internet communication with Sur-Gard System III / II
- Panel transmission monitoring for up to four phone numbers

Technical Specifications

The input voltage to the GS3060 can be drawn from the UL/ULC Listed control panel or provided by an external UL/ULC Listed power supply rated for the application (external power-limited source).

NOTE: The power supply must be Class II, Power Limited.

Ratings

Power Supply Ratings

Input Voltage: 9-14Vdc (JP3-OFF; 13.8Vdc required for normal, long-term operation)

..... 9-14Vdc (JP3-ON; 13.8Vdc recommended)

Current: 120mA* (JP3 - OFF and internal battery required) or 500mA* (JP3 ON)

* Plus any current drawn from the GS3060 AUX+ terminal

Battery: sealed, rechargeable type, rated 12V/1.2Ah

NOTE: Battery must be replaced every 3-5 years.

Charging current: 50mA

Current consumption

Standby current: 120mA

Alarm (Transmitting) current: 450mA

PGM outputs: Four, open collector, rated 50mA

Operating frequency: 850/1900MHz

Antenna gain: 2.0dBi

Environmental specifications

Operating temperature: 0°C-49°C (32°F-120°F)

Humidity: 93%RH Maximum (Non-Condensing)

Mechanical specifications

Metal enclosure, painted; dimensions: 138mm x 224mm x 55mm / 5.4" x 8.8" x 2.2"

Weight (without battery): 900g / 3.2oz

Internal Event Buffer (communications): 256 Events (not viewable)

Maximum loop resistance of line between the device connected in series on T1/R1: 1KOhm

This equipment GS3060 is fixed and shall be installed by Service Persons only (Service Person is defined as a person having the appropriate technical training and experience necessary to be aware of hazards to which that person may be exposed in performing a task, and of measures available to minimize the risks to that person or other persons). It shall be installed and used within an environment that provides the pollution degree max 2, over voltages category II, in non-hazardous, indoor locations only. This manual shall be used with the Installation Manual of the relevant alarm control panel. All instructions specified within that manual must be observed.

Description

This GS3060 manages transmissions to a central station and can simulate the land line in the event of trouble (e.g. land line down) or even substitute the land line completely in areas where the GSM service is provided and a land line is not available.

The GS3060 has the capability of communicating alarm signals via the GPRS data network. This capability ensures a fast, reliable path to central stations equipped with a Sur-Gard System III or System II receiver. By connecting a GS3060 to a control panel's standard PSTN interface, telephone-based Contact ID signals are decoded and seamlessly routed through the GPRS network to any of the compatible receiver options.

The performance of the GS3060 depends greatly on GSM network coverage. Therefore, it should not be mounted without first performing placement tests to determine the best location for reception (minimum of one green LED ON). Optional antenna kits – GS15/25/50-ANT (15ft/4.6m, 25ft/7.6m or 50ft/15.2m) – are available.

The GS3060 requires enrollment with CONNECT 24 to operate. Dealer application forms and additional information on the CONNECT 24 Voice Response Unit (VRU) and web user interface can be found at www.connect24.com, or at the following telephone numbers:

USA 1-888-251-7458

CANADA 1-888-955-5583

For UL Residential Fire and Burglary installations, the GS3060 is listed as a primary (sole) means of communication or as a back up when used in conjunction with a POTS line (dialer).

For UL Commercial Burglary installations, the GS3060 is listed for supplementary (back up) use in conjunction with a POTS line (dialer).

The GS3060 shall be powered from any compatible Listed control unit or compatible listed power supply that provides an output voltage within the range of 9-14Vdc. The power supply shall be listed for burglary applications and provide a minimum of 4 hours standby power capabilities. An example of a suitable Listed compatible control unit is the DSC Model PC1864 with an AUX output rated 11.1 – 12.6Vdc. An example of a suitable Listed power supply is DSC Model PC5204 with an AUX output rated 11.6 – 12.6Vdc.

For ULC Commercial Fire Monitoring installations the GS3060 is listed as a passive communication system when used in conjunction with a POTS line (dialer). Fire alarms shall be sent simultaneously over both communication methods (GSM network and PSTN).

For ULC Commercial Burglary installations the GS3060 is listed as a passive communication system with communication line security level P2 when used as a back up in conjunction with a POTS line (dialer).

For ULC Residential Fire and Burglary installations the GS3060 is listed as a primary (sole) means of communication or as a back up when used in conjunction with a POTS line (dialer).

ATTENTION: The GS3060 is equipped with a current limiter that limits current demand on the 12Vdc power input to 120mA. The current limiter is enabled by default (see Part# 8 in 'Identification of Parts' on page 3) with JP3 in the OFF position. The current limiter can be disabled (bypassed) with jumper JP3 in the ON position. When the GS3060 12Vdc power input is supplied by the Alarm Panel Aux+ output, DSC recommends that the current limiter be active to limit the demand from the panel. If the alarm panel is intended to supply all of the current demand, you must ensure that the panel can supply 500mA and that the current limiter is disabled. When the GS3060 is transmitting, the current demand exceeds 120 mA (500mA). With the current limiter in place, the additional current demand is supplied by the GS3060 battery.

NOTE: With the current limiter active, there is a risk of discharging the GS3060 battery when transmission frequency is high. The back up battery must always be connected to the device when the current limiter is enabled.

If power to the GS3060 is supplied by an external power supply (recommended 13.8 Vdc, 0.7A), the current limiter must be disabled to allow the full current demand to be supplied. In this configuration the GS3060 battery is not required.

IDENTIFICATION OF PARTS

Figure 1 - Parts

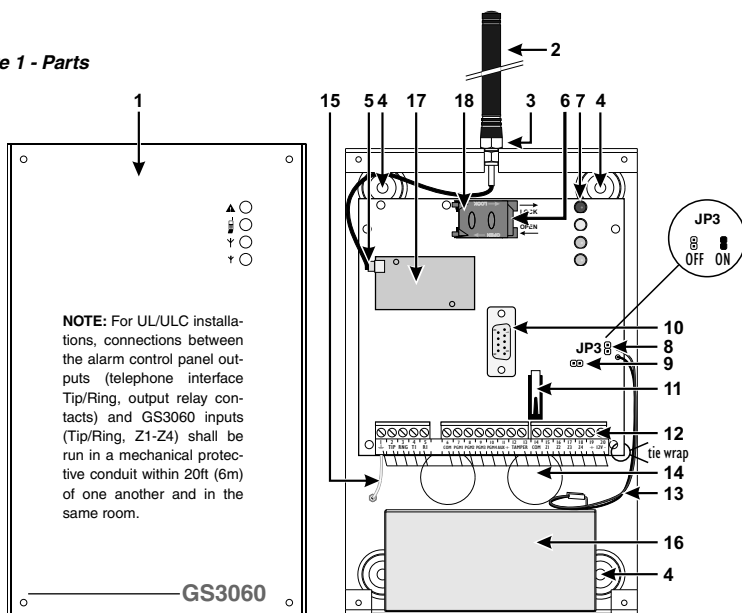

NOTE: For UL/ULC installations, connections between the alarm control panel outputs (telephone interface Tip/Ring, output relay contacts) and GS3060 inputs (Tip/Ring, Z1-Z4) shall be run in a mechanical protective conduit within 20ft (6m) of one another and in the same room.

GS3060

All circuits are classified for UL installations as Power Limited/Class II Power Limited except for the battery leads which are not power limited. Do not route any wiring over circuit boards. Maintain at least 1" (25.4mm) separation. A minimum 1/4" (6.4mm) of separation must be maintained at all points between Power Limited wiring and all other non-Power Limited wiring. Route wires as indicated above.

PARTS	
1	Metal Casing
2	GSM Antenna
3	GSM Antenna Mounting Hardware
4	Anchor Screw Holes (3mm)
5	Connector for GSM Antenna
6	SIM Card
7	Status LEDs (see page 5)
8	JP3 Current Limitation Jumper (refer to ratings section)
9	Programming Jumper (Do not short these pins)
10	RS-232 Connector
11	Tamper Switch
12	Terminal Blocks
13	Battery Leads
14	Cable Entry
15	Earth Ground Wire
16	12V-1.2Ah Battery
17	GSM Radio Module
18	SIM Card Holder

INSTALLING THE GS3060

CONNECT 24 Enrollment Information

Only authorized dealers can enroll a GS3060 with CONNECT 24. Dealer application forms and additional information on the CONNECT 24 Voice Response Unit can be found at the CONNECT 24 web site www.connect24.com. Please contact CONNECT 24 at the number below for assistance:

USA 1-888-251-7458

CANADA 1-888-955-5583

NOTE: Steps 1 and 2 should be completed before turning on the GS3060 unit.

NOTE: Before inserting or removing the SIM card, please ensure the unit is turned off.

STEP 1 - Activate Your SIM Card

Your SIM card must be activated with Connect 24 prior to use. **Please call the Voice Response Unit (VRU) at least 24 hrs prior to installation at 1-866-910-3865.**

STEP 2 - Initialize the GS3060 with Connect 24

Call the VRU at the toll-free number. Follow the voice prompts and enter your profile number, installer ID number, installer PIN number and central station number. Ensure that all information is available and at hand before calling the VRU. This information can be found in your VRU Enrollment Package.

STEP 3 - Determine Best Signal Location

1. Unscrew the four screws securing the front panel to the cabinet. Remove the front panel.
2. Fit the GSM antenna [2]. Ensure the GSM antenna mounting hardware is fastened securely [3].
3. Attach the GSM radio module with the GSM antenna connector. Ensure that the connector is secure.
4. Turn on the GS3060 and check the signal strength.
 - Connect the battery to the RED and BLK battery leads.
 - Connect the DC power source to +/- 12V terminals.
 - Allow the unit to power up.
 - The green LEDs will indicate the signal strength. The bottom green LED must be on for the location to be acceptable. Please refer to the 'Status LEDs' section for more information.
5. Power down the GS3060 by removing the DC power source and battery leads.

STEP 4 - Connect the GS3060

1. Using the cabinet, mark the four screw locations. Drill the anchor screw holes.

NOTE: Check for cable conduits and water pipes before drilling.

2. Using anchor screws (not provided), mount the cabinet to the wall.
3. Run the cables through the cable entry [14] or through the cabinet knockouts.
4. Complete the connections on the terminal blocks [12]. **NOTE: Ensure that power and Telco circuit connections are made only after the cabinet has been secured to the building or structure, and has been connected to the protective earth ground.**

Descriptions of the terminals can be found in the 'Connecting the GS3060' section.

5. Reattach the front cover [1] securely to the cabinet.

NOTE: Please refer to Figure 2 at the end of this manual for wiring diagram.

CONNECTING THE GS3060

⊥ (1) Earth Ground

This terminal must be connected to the Mains Earth, in order to comply with the Telecommunications Network Safety Standards (Overvoltage Protection Requirements).

TIP (2) / RNG (3) External telephone line

These terminals must be connected directly to the incoming telephone line .

T1 (4) / R1 (5) Internal telephone line

These terminals must be connected to the TIP and RING of the control panel.

COM(6,14) Common

This terminal is connected internally to Power Ground.

PGM1 (7), PGM2 (8), PGM3 (9), PGM4 (10) Programmable open-collector outputs

These outputs can be activated by programmed events. Refer to 'Activating the Outputs' for details. The maximum current sink of each output must not exceed 50mA.

AUX+ (11) Auxiliary 12V Output - +12V Output, 200mA PTC Protected.

NOTE: Electrical current drawn from this terminal is drawn directly from the power supply. This must be added to the GS3060 current when determining the total draw on the host panel or power supply. Jumper JP3 does not limit the electrical current available on this output.

Tamper (12-13)

These terminals are connected in series to the Tamper switch [11]. They will close when the cabinet is properly closed, and will open when the front cover is removed.

Z1-Z4 (15-16-17-18) Programmable Inputs

These terminals can be set up to trigger events. Refer to 'Inputs' for details.

12V (19), COM (20) Device Power Supply

These terminals must be connected to a rated power supply. Once the connections are completed, connect the battery leads (Red and Black wires [13]) to a 12V, 1.2Ah battery.

Jumper JP3

JP3 ON - Full power, including standby capacity, comes from the host panel or external power supply. Supply must be capable of up to 700mA. The GS3060 battery must *not* be connected.

JP3 OFF - Current Limiting Mode. Host panel or external supply provides standby current. Supply must be capable of 120mA plus any current drawn from AUX+ terminal. GS3060 battery must be installed for proper operation.

NOTE: The power supply must have a minimum voltage of 13.5V to ensure a sufficient battery charge.

NOTE: This mode of operation must not be used for ULC Listed Fire Monitoring installations.

NOTE: When disposing of batteries, follow the instructions and precautions printed on the batteries, and contact your municipal offices for information on the disposal of used batteries.

STATUS LEDS

The GS3060 interface has four status LEDs. The following describes the control panel status LEDs.

NOTE: The top two LEDs will blink during the Initializing and Programming phases.

▲ RED — This LED is normally *Off*; it will blink in the event of a trouble. This LED will switch on within three minutes in the event of GSM Module [17] trouble, or when the GSM Network is unavailable 'No Service'. If this LED blinks, the following list will indicate the specific trouble based on the number of blinks, by priority. When turned on, the GS3060 will check for trouble conditions to be restored in the order listed below. It will indicate the status of the highest priority, unrestored trouble condition with the corresponding number of flashes of the red LED. Once the highest priority trouble condition has been cleared, the next highest priority trouble condition will be displayed.

1 flash - Battery Trouble (Battery absent or battery with low voltage output).

2 flashes - Radio/SIM Trouble (Battery absent or SIM Card disconnected).

3 flashes - GSM Network Problem (SIM not active, poor signal strength, antenna not connected).

4 flashes - Insufficient Signal Strength (poor location).

5 flashes - Connect 24 Configuration SMS Trouble (Improper VRU programming. Once the configuration is ready, turn off power for 2-3 seconds to allow the unit to restart and request again).

6 flashes - Receiver not available (Improper VRU programming, receiver absent).

7 flashes - Power Supply Trouble (DC power supply absent).

Off - No Troubles

📞 YELLOW - When this LED is on (solid) there is a Phone Line Trouble condition. This LED will switch on when the interface switches to the GSM Network (due to a Land Line trouble condition). This LED will flash slowly in the event of an incoming or outgoing voice call (regardless of the operating status of the land line). This LED can also flash quickly once (GPRS TX) or twice (GPRS RX).

↕ GREEN (Top) — When this LED is on, the reception is optimal. This LED will switch On only when the other Green LED is on.

↕ GREEN (Bottom) — If this LED is Off and the Red LED is on, the GSM Network service is unavailable (**NO SERVICE**). This LED will flash when the GSM Network reception is poor. If this LED is on, the GS3060 will be able to communicate to the GSM network.

OPERATING PRINCIPLES

Simulated Land Line Mode

The simulated land line provides the alarm control panel (with dialer interface) with a backup line in the event of PSTN line trouble. If the voltage on the land line terminals (TIP/RNG) drops below 4V for a period of between 10 seconds and 45 seconds - depending on the device connected to the T1/R1 terminals - the GS3060 will switch the connected telephone device to the GSM network. After waiting between 30 seconds and 40 seconds, it will check the land line for one of the following:

- If the land line has been restored, the GS3060 will switch the connected device back to the land line, OR
 - If the land line is still down, the GS3060 will continue the simulation until the land line is restored.
- The GS3060 will not switch during ongoing calls.

NOTE: When the land line is down, the GS3060 will provide a dial tone to any device connected to T1 and R1, including any telephones on the premises. The phones on the premises will not, however, be able to dial out over the GS3060.

PTM (Panel Transmission Monitoring)

The GS3060 can also monitor the panel's attempt to communicate with the central station. If it determines that the panel is having difficulty, it will switch the line to the GSM network. This feature is only active when the GS3060 is configured as a backup communicator. This feature is in addition to the regular line voltage detection.

The GS3060 will monitor the phone line for four consecutive failed attempts within a 12-minute window. A failed attempt is assumed to have occurred when a line seizure takes place during dialing (either the alarm panel or the customer telephone), but no 1400Hz tone (or Contact Kiss-off) is sent from the receiver.

Once the conditions for a failed attempt are met, the GS3060 will connect the panel to the GSM network to communicate the events. Once the GS3060 switches the line it will stay in this mode until the panel hangs up. On the next event the GS3060 will restart the error detection sequence before switching.

The GS3060 will perform this sequence on any phone number that is detected on the line. Specific central station phone numbers can be programmed into the GS3060 if desired. Up to four, 20-digit numbers can be added to your installer profile at Connect 24. If programmed, the GS3060 will only look for Contact ID Kiss-off after these numbers are dialed. A Telephone Line Monitoring trouble (PGM output activation and/or reporting code if applicable) will also be activated and/or transmitted when the PTM is activated. A restoral will be sent at the end of the call.

GPRS Sequence

- When an alarm is triggered, the control panel goes off-hook.
- The GS3060 will assert a dial tone.
- Control panel dials the number of the central station. Ensure that the alarm panel inserts a minimum one second pause, or has Dial Tone Search enabled before dialing the number.
- The GS3060 detects the DTMF dialing and stops dial tone.

NOTE: The GS3060 is unable to decode pulse dialing.

- The GS3060 will send the required Contact ID dual-tone handshake to the panel.
- After receiving the handshake, the panel transmits an alarm message in Contact ID format.
- The GS3060 decodes and transforms the Contact ID digits into an IP packet and sends it to the central station receiver over the GPRS network.
- The receiver acknowledges the alarm and sends a command to the GS3060 to generate the corresponding 1400Hz Kiss-off signal for a minimum of 800msec.
- After the GS3060 generates a Kiss-off signal, it sends the next alarm or, if no further alarms need to be sent, the panel goes on-hook.

Inputs

The GS3060 has four inputs that can be used to trigger specific communications. These events will transmit using Contact ID format with Inputs 1-4 reporting as [991] to [994] respectively. Default settings are:

INPUT 1 - FIRE

INPUT 3 - BURGLARY

INPUT 2 - PANIC ALARM

INPUT 4 - SYSTEM TROUBLE

These inputs are normally open and will activate when a short condition is detected between the terminal and the COM. Refer to the GS3060 Wiring Diagram (Figure 2) at the back of this manual.

NOTE: These inputs communicate using Contact ID format.

NOTE: For UL/ULC installations, connections between alarm panel outputs and GS3060 inputs shall be run in protective mechanical conduits. To reduce interference with the antenna, it is recommended that the metal conduit is not connected to the knock-outs in the top of the cabinet.

Outputs

The GS3060 has four programmable outputs to activate in response to the associated events. Refer to the GS3060 Wiring Diagram (Figure 2) at the back of this manual.

Activating the Outputs

The GS3060 has four open collector outputs capable of a maximum of 50mA. Internal events on the GS3060 can trigger the outputs to turn on an LED or activate an input on the host panel. The default settings are as follows.

OUTPUT 1 Land Line Trouble - Output is normally high and will switch to ground when the telephone line is down.

OUTPUT 2 GSM Module or Network Trouble - Output is normally high and will switch to ground when the GS3060 can not communicate with the GSM network.

OUTPUT 3 Power Supply or Battery Trouble - Output is normally high and will switch to ground when there is a problem with the power source.

OUTPUT 4 General Module Trouble - Output is normally low and will switch to high when a GSM Trouble, Power Supply/Battery Trouble and/or a Failure to Communicate (FTC) trouble is detected.

NOTE: PGM4 MUST be connected to the control panel as shown in Figure 4. Program the control panel input Zone/Point as 24hr 'Supervisory' with keypad-only notification when activated. Output 4 on the GS3060 must be set as 'Active High'.

NOTE: Once an output has been activated automatically, it will not restore its state until all the causes of activation are cleared.

Contact ID

Events Description

Event Codes

INPUT 1 ACTIVATION:	E110 FIRE ZONE 001 991
INPUT 1 RESTORAL:	R110 FIRE ZONE 001 991
INPUT 2 ACTIVATION:	E120 PANIC ALARM ZONE 002 992
INPUT 2 RESTORAL:	R120 PANIC ALARM ZONE 002 992
INPUT 3 ACTIVATION:	E130 BURGLARY ZONE 003 993
INPUT 3 RESTORAL:	R130 BURGLARY ZONE 003 993
INPUT 4 ACTIVATION:	E300 SYSTEM TROUBLE ZONE 004 994
INPUT 4 RESTORAL:	R300 SYSTEM TROUBLE ZONE 004 994
PSTN LINE DOWN:	E351 TELCO 1 FAULT 000
PSTN LINE RESTORAL:	R351 TELCO 1 FAULT 000
12V INPUT LOSS:	E337 EXP. MOD. DC LOSS 000
12V INPUT RESTORAL:	R337 EXP. MOD. DC LOSS 000
LOW BATTERY ALERT:	E338 EXP. MOD. LOW BAT 000
LOW BATTERY RESTORAL:	R338 EXP. MOD. LOW BAT 000
PERIODIC REPORT:	E603 PERIODIC RF XMISSION 000
PERIODIC REPORT WITH OFF-NORMAL CONDITION:	E608 PERIODIC TEST XMISSION SYSTEM TROUBLE PRESENT 000
GSM UNIT ACTIVATION:	R552 RADIO XMITTER DISABLED 000
GSM INTERNAL BUFFER FULL:	E624 EVENT LOG OVERFLOW 000
FTC RESTORAL:	R354 FAILURE TO COMMUNICATE 000

CONNECT 24 REMOTE PROGRAMMING

The inputs, outputs, and other features can be remotely programmed through Connect 24 (C 24) for fast and convenient installation using the internet.

NOTE: This programming option has not been investigated by UL.

GS3060 WIRING DIAGRAMS

WARNING!
HIGH VOLTAGE. DISCONNECT AC
POWER & TELEPHONE LINES
PRIOR TO SERVICING

This Connection is necessary

GS3060

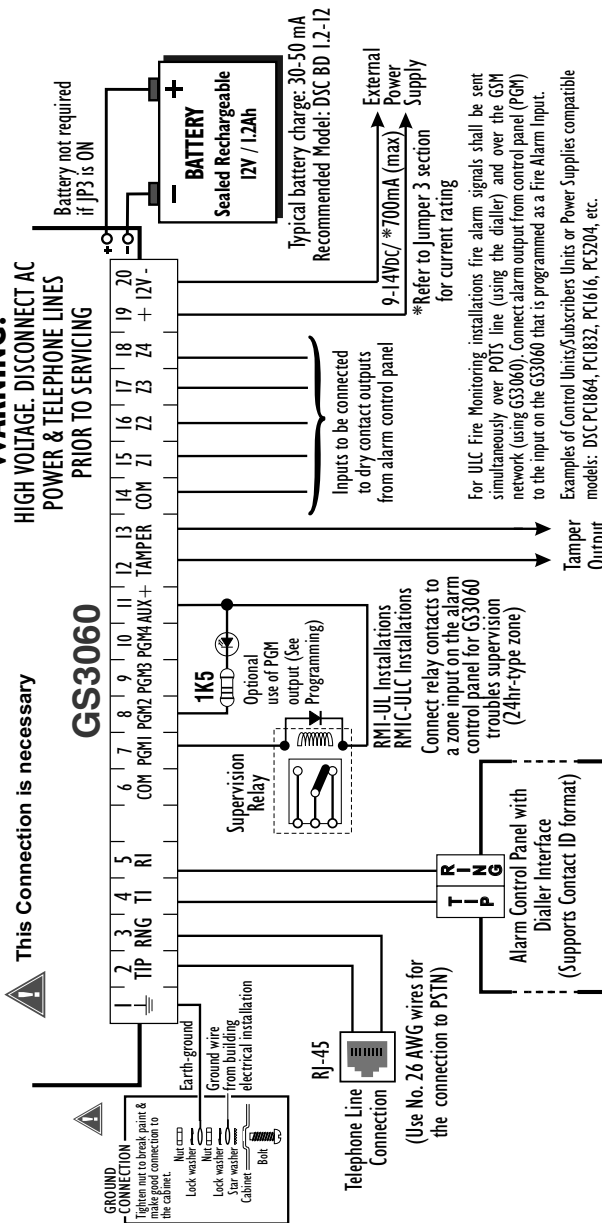

WARNING: Incorrect connections may result in PTC failure or improper operation. Inspect wiring and ensure connections are correct before turning on. All circuits are classified for UL installations as Power Limited/Class II Power Limited except for the battery leads which are not power limited. Do not route any wiring over circuit boards. Maintain at least 1" (25.4mm) separation. A minimum 1/4" (6.4mm) separation must be maintained at all points between Power Limited wiring and all other Non-Power Limited wiring. Route wires as indicated in the diagram.
NOTE: For ULC Commercial Fire and Burglary Installation requirements please refer to Figures 5, 6, 7 & 8 and to the ULC Installation Guide P/N 29002157R009.

Figure 2 - Wiring Diagram

GS3060 WIRING DIAGRAMS

Figure 3 - Telephone Connection

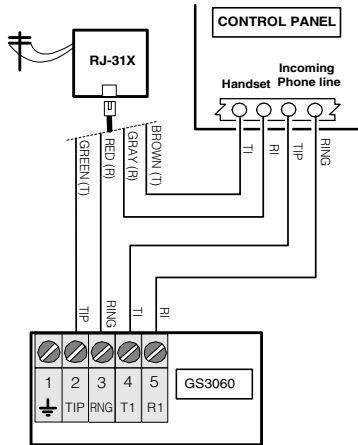
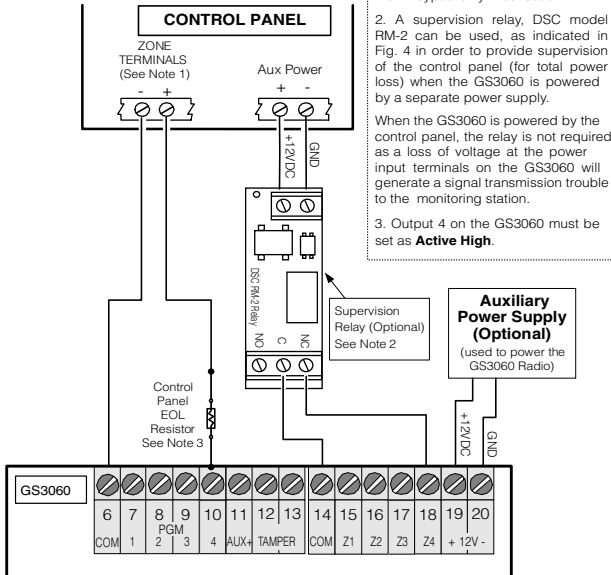

Figure 4 - Power Supply And Supervision Wiring Diagram



NOTES:

1. Program the control panel's Input Zone/Point as 24hr 'Supervisory' type with keypad-only notification
2. A supervision relay, DSC model RM-2 can be used, as indicated in Fig. 4 in order to provide supervision of the control panel (for total power loss) when the GS3060 is powered by a separate power supply.
When the GS3060 is powered by the control panel, the relay is not required as a loss of voltage at the power input terminals on the GS3060 will generate a signal transmission trouble to the monitoring station.
3. Output 4 on the GS3060 must be set as **Active High**.

GS3060 WIRING DIAGRAMS

Figure 5 - Fire Alarm Control Unit and GSM Transmitter

Wiring Diagram for Fire Alarm Control Unit (with dialler) and GSM Transmitter (Passive Communication System)

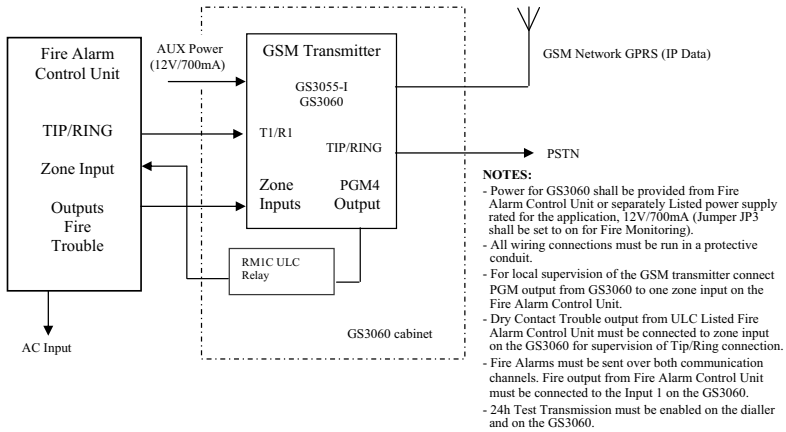
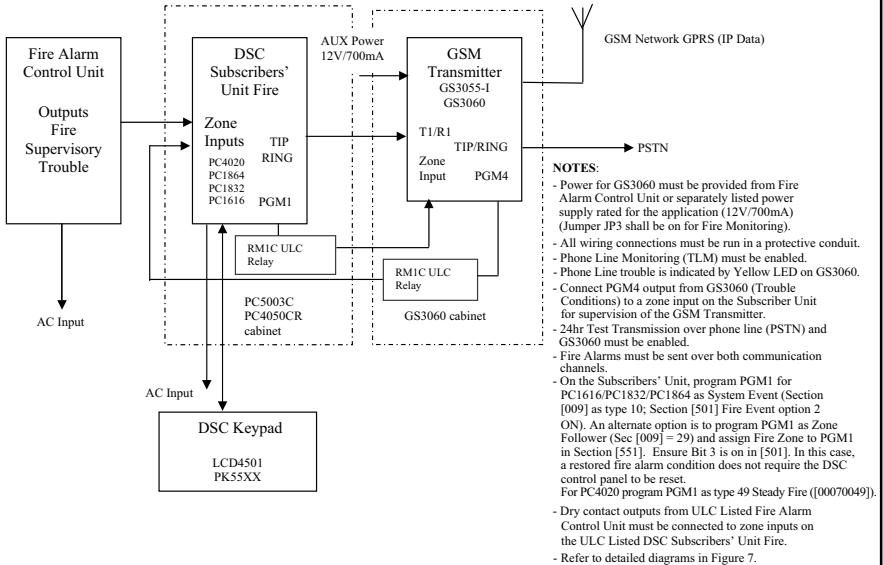

Figure 6a - DSC Subscribers' Unit Fire and GSM Transmitter Mounted in the Same Room

Wiring Diagram for DSC Subscribers' Unit Fire and GSM Transmitter (Passive Communication System)



GS3060 WIRING DIAGRAMS

Figure 6b - DSC Subscribers' Unit Fire and GSM Transmitter Mounted Remotely

**Alternate Wiring Diagram for DSC Subscribers' Unit Fire and GSM Transmitter
Passive Communication System -Using Phone Line Supervision Relay**

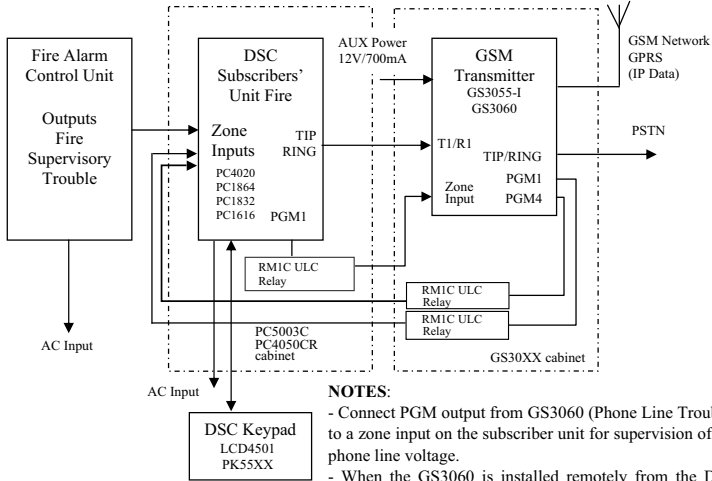

NOTES:

- Connect PGM output from GS3060 (Phone Line Trouble) to a zone input on the subscriber unit for supervision of the phone line voltage.
- When the GS3060 is installed remotely from the DSC Control Panel, it is required to monitor the Phone Line Trouble condition at the keypad by using an additional RMIC Relay.
- Refer to detailed diagrams in Figure 8.

**PLEASE NOTE THAT EITHER RMIC ULC OR RM2 RELAYS
CAN BE USED FOR ULC INSTALLATIONS**

GS3060 WIRING DIAGRAMS

Figure 7 - Connection Details for GSM Supervision Relay and Redundant Fire Alarm Transmission

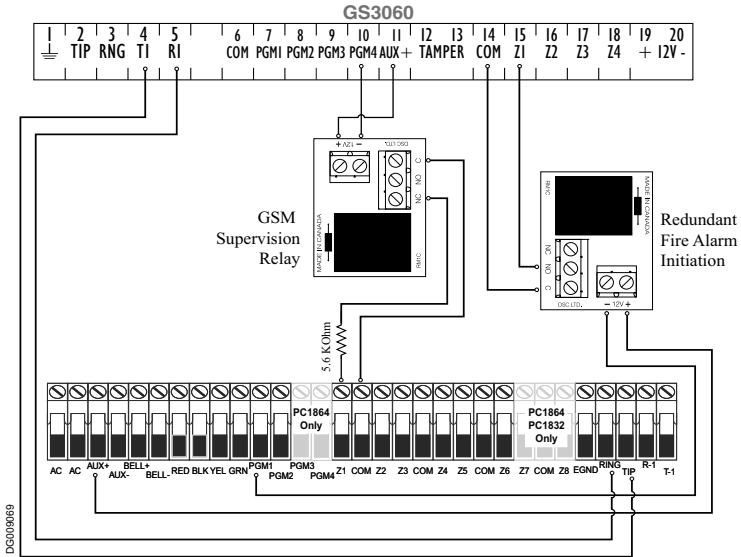

NOTE: Use EOL resistors in series with N.C. contacts of the relay

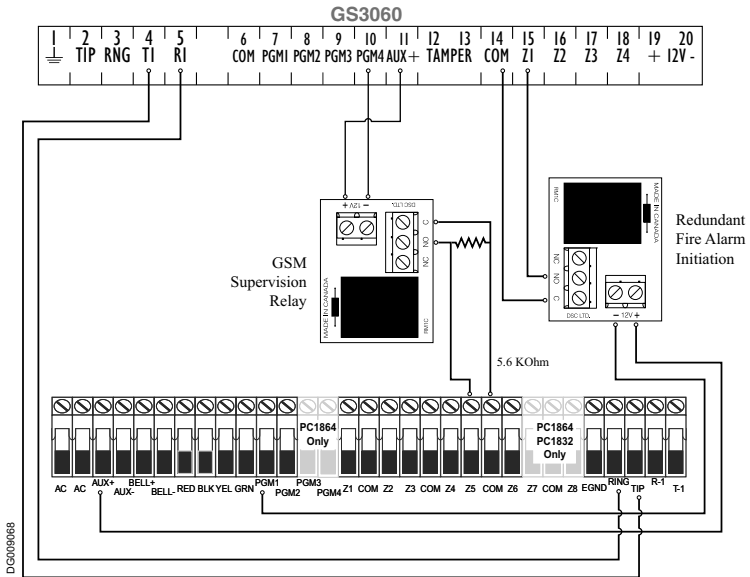

NOTE: Use EOL resistor in parallel with N.O. contacts of the relay.

GS3060 WIRING DIAGRAMS

Figure 8 - Connection Details for GSM Supervision Relay, Phone Line Supervision and Redundant Fire Alarm Transmission

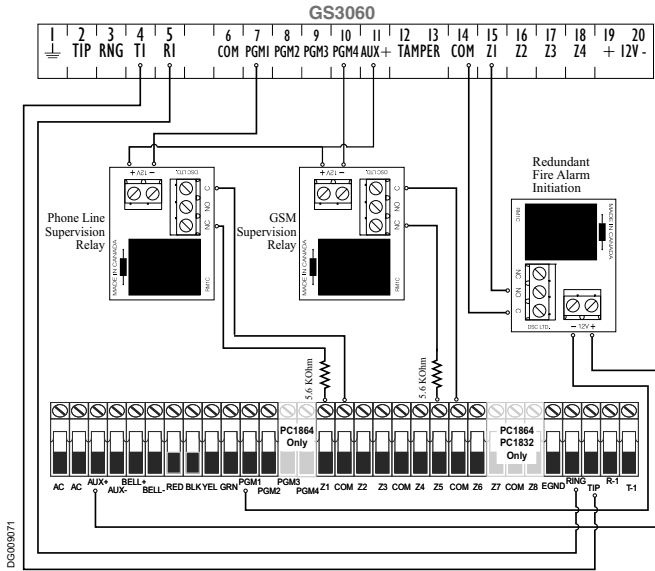

NOTE: Use EOL resistors in series with N.C. contacts of the relay.

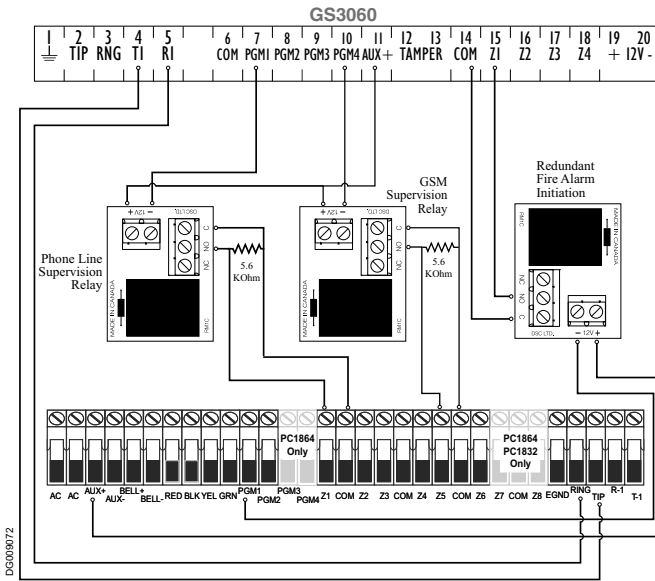

NOTE: Use EOL resistors in parallel with N.O. contacts of the relay.

FCC COMPLIANCE STATEMENT

CAUTION: Changes or modifications not expressly approved by Digital Security Controls could void your authority to use this equipment. This equipment generates and uses radio frequency energy and if not installed and used properly, in strict accordance with the manufacturer's instructions, may cause interference to radio and television reception. It has been type tested and found to comply with the limits for Class B device in accordance with the specifications in Subpart "B" of Part 15 of FCC Rules, which are designed to provide reasonable protection against such interference in any residential installation. However, there is no guarantee that interference will not occur in a particular installation. If this equipment does cause interference to television or radio reception, which can be determined by turning the equipment off and on, the user is encouraged to try to correct the interference by one or more of the following measures:

- Re-orient the receiving antenna
- Relocate the alarm control with respect to the receiver
- Move the alarm control away from the receiver
- Connect the alarm control into a different outlet so that alarm control and receiver are on different circuits.

If necessary, the user should consult the dealer or an experienced radio/television technician for additional suggestions. The user may find the following booklet prepared by the FCC helpful: "How to Identify and Resolve Radio/Television Interference Problems". This booklet is available from the U.S. Government Printing Office, Washington, D.C. 20402, Stock # 004-000-00345-4.

IMPORTANT INFORMATION

This equipment complies with Part 68 of the FCC Rules. On the side of this equipment is a label that contains, among other information, the FCC registration number and ringer equivalence number (REN) for this equipment. If requested, this number must be provided to the Telephone Company.

GS3060 Product Identifier US: F53M000BGS3060

REN: 0.0B

USOC Jack: RJ-31X

Telephone Connection Requirements

A plug and jack used to connect this equipment to the premises wiring and telephone network must comply with the applicable FCC Part 68 rules and requirements adopted by the ACTA. A compliant telephone cord and modular plug is provided with this product. It is designed to be connected to a compatible modular jack that is also compliant. See installation instructions for details.

Ringer Equivalence Number (REN)

The REN is used to determine the number of devices that may be connected to a telephone line. Excessive RENs on a telephone line may result in the devices not ringing in response to an incoming call.

In most but not all areas, the sum of RENs should not exceed five (5.0). To be certain of the number of devices that may be connected to a line, as determined by the total RENs, contact the local Telephone Company. For products approved after July 23, 2001, the REN for this product is part of the product identifier that has the format, US: AAAEQ##TXXXX. The digits represented by ## are the REN without a decimal point (e.g., 03 is a REN of 0.3). For earlier products, the REN is separately shown on the label.

Incidence of Harm

If this equipment GS3060 causes harm to the telephone network, the telephone company will notify you in advance that temporary discontinuance of service may be required. But if advance notice is not practical, the Telephone Company will notify the customer as soon as possible. Also, you will be advised of your right to file a complaint with the FCC if you believe it is necessary.

Changes in Telephone Company Equipment or Facilities

The Telephone Company may make changes in its facilities, equipment, operations or procedures that could affect the operation of the equipment. If this happens the Telephone Company will provide advance notice in order for you to make necessary modifications to maintain uninterrupted service.

Equipment Maintenance Facility

If trouble is experienced with this equipment for repair or warranty information, please contact the facility indicated below. If the equipment

is causing harm to the telephone network, the Telephone Company may request that you disconnect the equipment until the problem is solved. This equipment is of a type that is not intended to be repaired by the end user.

DSC c/o APL Logistics, 757 Douglas Hill Rd., Lithia Springs, GA 30122

Additional Information

Connection to party line service is subject to state tariffs. Contact the state public utility commission, public service commission or corporation commission for information.

Alarm dialling equipment must be able to seize the telephone line and place a call in an emergency situation. It must be able to do this even if other equipment (telephone, answering system, computer modem, etc.) already has the telephone line in use. To do so, alarm dialling equipment must be connected to a properly installed RJ-31X jack that is electrically in series with and ahead of all other equipment attached to the same telephone line. Proper installation is depicted in the figure below. If you have any questions concerning these instructions, you should consult your telephone company or a qualified installer about installing the RJ-31X jack and alarm dialling equipment for you.

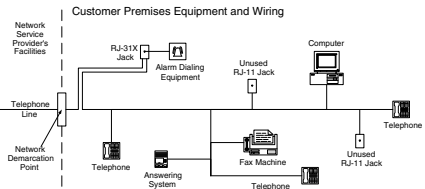

Industry Canada Compliance Statement

This Equipment meets the applicable Industry Canada Terminal Equipment Technical Specifications. This is confirmed by the registration number. The abbreviation, IC, before the registration number signifies that registration was performed based on a Declaration of Conformity indicating that Industry Canada technical specifications were met. It does not imply that that Industry Canada approved the equipment. The Ringer Equivalence Number (REN) for this terminal equipment is 0.0. The REN assigned to each terminal equipment provides an indication of the maximum number of terminals allowed to be connected to a telephone interface. The termination on an interface may consist of any combination of devices subject only to the requirement that the sum of the Ringer Equivalence Numbers of all devices does not exceed 5.

Cet équipement est conforme aux spécifications techniques applicables aux équipements terminaux d'Industrie Canada. Ceci est confirmé par le numéro d'enregistrement. L'abréviation IC précédant le numéro d'enregistrement signifie que l'enregistrement a été effectué sur la base de la Déclaration de conformité indiquant que le produit est conforme aux spécifications techniques d'Industrie Canada. Ceci n'implique pas que le produit ait été approuvé par Industrie Canada.

Le nombre équivalent de sonneries (REN) de cet appareil terminal est 0.0. Le REN attribué à chaque équipement terminal fournit une indication sur le nombre maximum de terminaux pouvant être connectés sur une interface téléphonique. La terminaison sur une interface peut constituer en n'importe quelle combinaison d'appareils, à la condition seulement que la somme des Nombres équivalents de sonneries de tous les appareils ne soit pas supérieure à 5.

This Class B digital apparatus meets all requirements of the Canadian interference-causing equipment regulations. Cet appareil numérique de la Classe B respecte toutes les exigences de règlement sur le matériel brouilleur du Canada.

The term "IC:" before the radio certification number only signifies that Industry Canada technical specifications were met.

The reference to the name GS3060 in this manual includes models GS3060 and GS3060L.

WARNING: To satisfy FCC RF exposure requirements for mobile transmitting devices, a separation distance of 20cm or more must be maintained between the antenna of this device and persons during device operation.

